

NOTE:
DREDGE PIPELINE MAY ENTER THE WEST MARSH CREATION AREA WITHIN THE BOOSTER ANCHORAGE AREA.



STATE OF LOUISIANA
 TYE E. FITZGERALD
 License No. 38153
 PROFESSIONAL ENGINEER
 12/12/2018

LEGEND	
	MARSH CREATION BORROW AREA
	MARSH CREATION AREA
	NO EXCAVATION
	DREDGE PIPELINE AND EQUIPMENT ACCESS CORRIDOR
	EARTHEN CONTAINMENT DIKE
	EQUIPMENT ACCESS CORRIDOR
	EARTHEN GAP CLOSURE
	MARSH CREATION AREA PERIMETER
	VERIFIED PIPELINE
	UNVERIFIED PIPELINE
	POTENTIAL ACCESS DREDGING
	POTENTIAL BOOSTER BARGE ANCHORAGE AREA
	SHEET PILE GAP CLOSURE
	ACTIVE WELL
	DRY AND PLUGGED WELL
	PERMIT EXPIRED - WELL
	PLUGGED AND ABANDONED WELL
	SHUT-IN PRODUCTIVE WELL
	SURVEY MONUMENT

PROJECT LAYOUT		COASTAL PROTECTION AND RESTORATION AUTHORITY 150 TERRACE AVENUE BATON ROUGE, LOUISIANA 70802	
NORTHWEST TURTLE BAY MARSH CREATION PROJECT		DESIGNED BY: T. MCCLAIN, E.I.	APPROVED BY: T. FITZGERALD, P.E. P.E. NO. 38153
STATE PROJECT NUMBER: BA-0125	DRAWN BY: K. CANTU	DATE: DEC. 2018	SHEET 3 OF 79
REV.	DATE	DESCRIPTION	BY

BORROW AREA		
LIMITS OF PAY		
	NORTHING	EASTING
1	382,043.00	3,661,323.26
2	382,042.40	3,663,722.11
3	380,510.37	3,663,721.50
4	380,510.37	3,665,574.10
5	378,608.70	3,665,574.10
6	378,608.70	3,661,323.74
LIMITS OF BORROW		
	NORTHING	EASTING
7	381,942.98	3,661,423.27
8	381,942.43	3,663,622.07
9	380,410.37	3,663,621.46
10	380,410.37	3,665,474.10
11	378,708.70	3,665,474.10
12	378,708.70	3,661,423.72

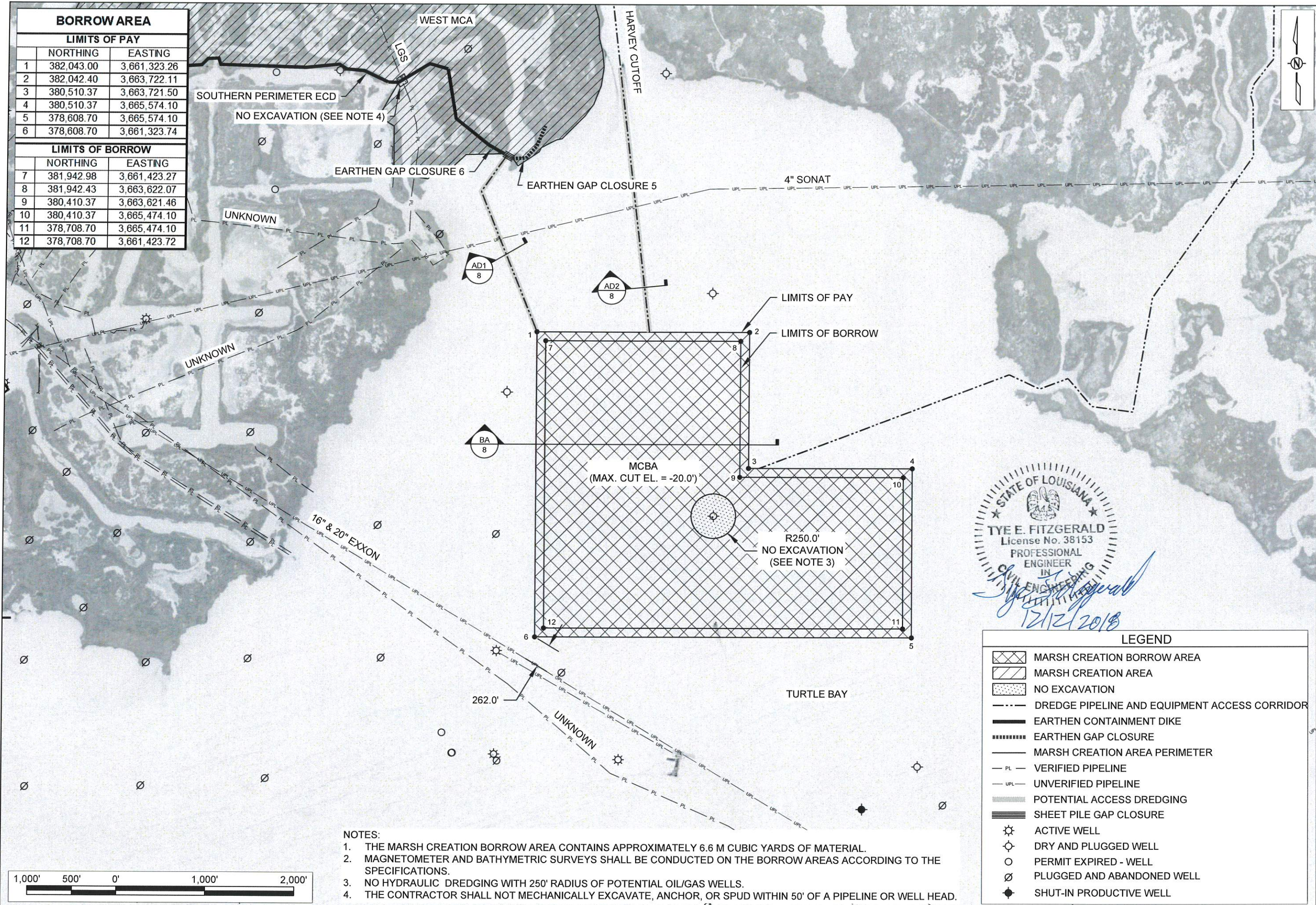

- NOTES:
1. THE MARSH CREATION BORROW AREA CONTAINS APPROXIMATELY 6.6 M CUBIC YARDS OF MATERIAL.
 2. MAGNETOMETER AND BATHYMETRIC SURVEYS SHALL BE CONDUCTED ON THE BORROW AREAS ACCORDING TO THE SPECIFICATIONS.
 3. NO HYDRAULIC DREDGING WITH 250' RADIUS OF POTENTIAL OIL/GAS WELLS.
 4. THE CONTRACTOR SHALL NOT MECHANICALLY EXCAVATE, ANCHOR, OR SPUD WITHIN 50' OF A PIPELINE OR WELL HEAD.



LEGEND	
	MARSH CREATION BORROW AREA
	MARSH CREATION AREA
	NO EXCAVATION
	DREDGE PIPELINE AND EQUIPMENT ACCESS CORRIDOR
	EARTHEN CONTAINMENT DIKE
	EARTHEN GAP CLOSURE
	MARSH CREATION AREA PERIMETER
	VERIFIED PIPELINE
	UNVERIFIED PIPELINE
	POTENTIAL ACCESS DREDGING
	SHEET PILE GAP CLOSURE
	ACTIVE WELL
	DRY AND PLUGGED WELL
	PERMIT EXPIRED - WELL
	PLUGGED AND ABANDONED WELL
	SHUT-IN PRODUCTIVE WELL

COASTAL PROTECTION AND RESTORATION AUTHORITY 150 TERRACE AVENUE BATON ROUGE, LOUISIANA 70802		REV.	DATE	DESCRIPTION	BY
MARSH CREATION BORROW AREA LAYOUT		NORTHWEST TURTLE BAY MARSH CREATION PROJECT			
DESIGNED BY: T. MCLAIN, E.I. APPROVED BY: T. FITZGERALD, P.E. P.E. NO. 38153		STATE PROJECT NUMBER: BA-0125 DRAWN BY: K. CANTU			
DATE: DEC. 2018		SHEET 4 OF 79			

**WEST MARSH CREATION AREA
PERIMETER COORDINATES**

	NORTHING	EASTING		NORTHING	EASTING
1	387,877.94	3,657,334.94	50	383,797.13	3,659,872.44
2	388,103.19	3,657,395.33	51	383,797.13	3,659,685.42
3	388,399.56	3,657,707.05	52	384,351.82	3,659,683.81
4	388,508.62	3,658,029.47	53	384,461.34	3,659,507.74
5	387,846.37	3,659,470.63	54	384,846.73	3,659,729.61
6	387,912.66	3,659,979.62	55	384,358.80	3,661,398.56
7	388,628.76	3,660,568.71	56	384,132.70	3,661,300.62
8	388,728.78	3,660,781.66	57	383,998.21	3,661,179.64
9	388,886.49	3,661,069.71	58	384,143.93	3,660,760.46
10	388,877.84	3,661,304.65	59	384,441.28	3,660,383.05
11	388,870.08	3,661,312.51	60	385,000.80	3,660,288.21
12	388,832.18	3,661,350.63	61	385,058.52	3,660,080.35
13	388,830.22	3,661,356.64	62	384,848.42	3,659,614.40
14	388,794.96	3,661,456.16	63	384,976.59	3,659,340.84
15	388,607.82	3,661,502.05	64	384,995.09	3,659,141.03
16	388,257.09	3,661,506.74	65	385,051.19	3,659,057.22
17	387,938.73	3,661,530.35	66	385,010.43	3,658,685.96
18	387,919.22	3,661,519.08	67	385,037.59	3,657,720.83
19	387,844.22	3,661,519.26	68	385,108.92	3,657,698.03
20	387,658.16	3,661,603.26	69	385,102.97	3,657,576.94
21	387,421.00	3,661,580.49	70	385,033.67	3,657,507.16
22	387,364.90	3,661,604.53	71	384,987.89	3,656,762.23
23	387,235.27	3,661,698.32	72	385,077.60	3,656,547.04
24	387,212.27	3,661,729.77	73	385,136.84	3,656,480.18
25	386,951.26	3,661,809.57	74	385,624.91	3,656,052.17
26	386,547.03	3,661,814.85	75	385,820.57	3,656,156.91
27	386,417.42	3,661,860.52	76	385,839.37	3,656,205.12
28	386,119.97	3,661,835.07	77	385,847.74	3,656,207.02
29	386,054.77	3,661,728.69	78	385,953.36	3,656,235.84
30	385,991.07	3,661,759.66	79	386,221.48	3,656,308.11
31	385,968.93	3,661,879.61	80	386,439.56	3,656,307.11
32	385,554.53	3,661,995.85	81	386,638.63	3,656,467.51
33	385,354.68	3,661,996.67	82	386,632.80	3,656,560.78
34	385,199.46	3,662,036.05	83	386,633.20	3,656,586.00
35	385,023.94	3,662,054.81	84	386,641.58	3,656,690.66
36	384,819.05	3,662,025.90	85	386,643.86	3,656,719.25
37	384,605.72	3,661,944.10	86	386,688.36	3,656,883.61
38	384,481.09	3,661,850.09	87	386,640.56	3,656,994.23
39	384,215.61	3,661,586.64	88	386,773.32	3,657,138.49
40	384,203.93	3,661,525.55	89	386,859.80	3,657,130.91
41	384,115.49	3,661,352.71	90	386,894.69	3,657,062.64
42	384,067.74	3,661,327.97	91	387,026.68	3,657,108.47
43	383,909.15	3,661,090.30	92	387,294.50	3,657,057.05
44	383,991.59	3,661,033.64	93	387,390.17	3,657,129.53
45	384,046.52	3,660,935.14	94	387,458.89	3,657,143.51
46	384,035.41	3,660,500.10	95	387,525.11	3,657,187.30
47	383,907.81	3,660,362.53	96	387,634.59	3,657,227.59
48	383,883.69	3,660,187.00	97	387,711.22	3,657,266.97
49	383,759.08	3,660,070.43			

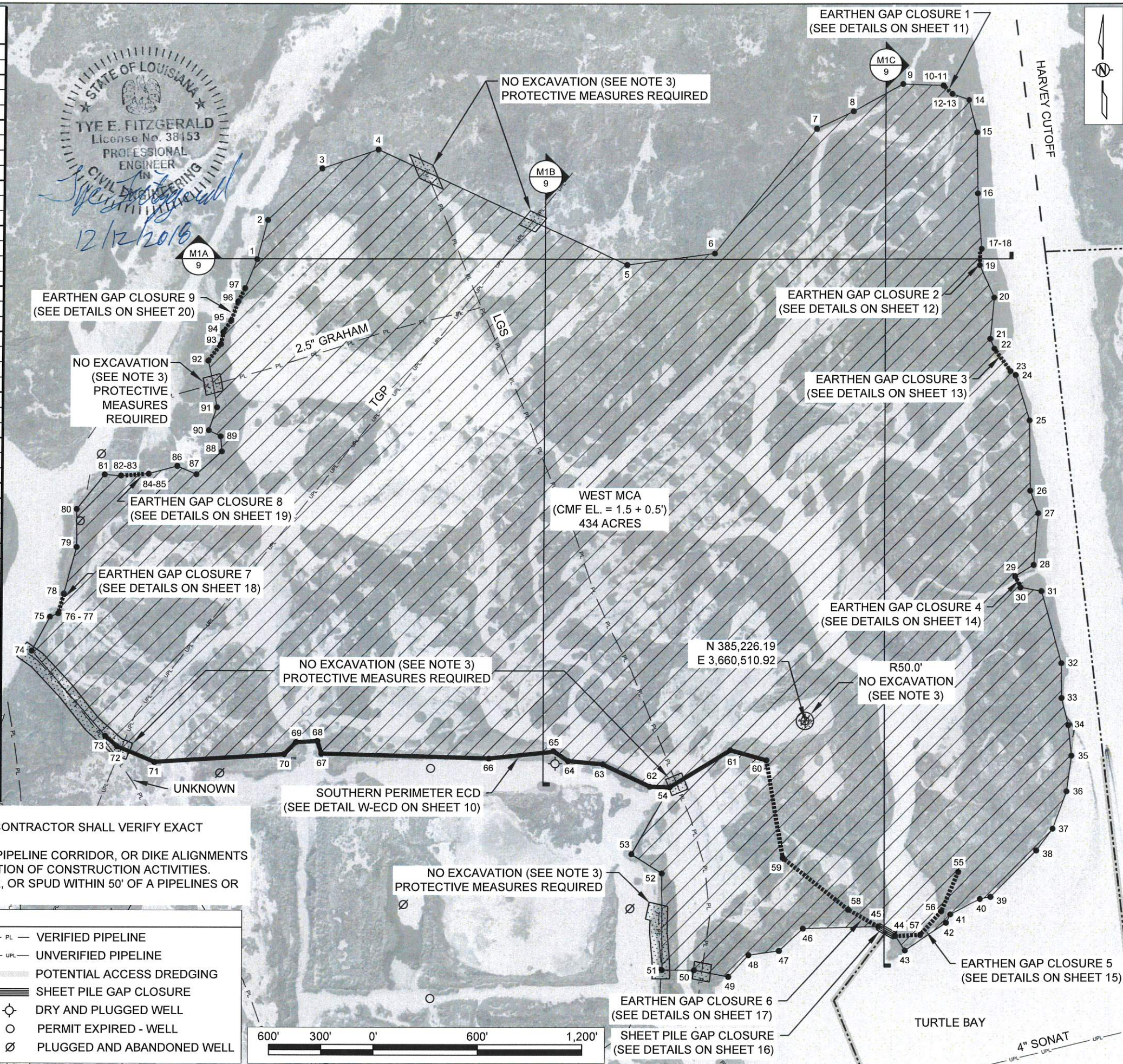

- NOTES:**
1. PIPELINE INFORMATION SHOWN ON PLANS IS APPROXIMATE. THE CONTRACTOR SHALL VERIFY EXACT LOCATIONS PRIOR TO BEGINNING CONSTRUCTION.
 2. ALL PIPELINES LOCATED WITHIN 150' OF THE FILL AREAS, DREDGE PIPELINE CORRIDOR, OR DIKE ALIGNMENTS SHALL BE PROBED AND THEIR LOCATIONS MARKED FOR THE DURATION OF CONSTRUCTION ACTIVITIES.
 3. THE CONTRACTOR SHALL NOT MECHANICALLY EXCAVATE, ANCHOR, OR SPUD WITHIN 50' OF A PIPELINES OR WELL HEADS.

LEGEND

MARSH CREATION AREA	VERIFIED PIPELINE
NO EXCAVATION	UNVERIFIED PIPELINE
DREDGE PIPELINE AND EQUIPMENT ACCESS CORRIDOR	POTENTIAL ACCESS DREDGING
EARTHEN CONTAINMENT DIKE	SHEET PILE GAP CLOSURE
EQUIPMENT ACCESS CORRIDOR	DRY AND PLUGGED WELL
EARTHEN GAP CLOSURE	PERMIT EXPIRED - WELL
MARSH CREATION AREA PERIMETER	PLUGGED AND ABANDONED WELL

<p>COASTAL PROTECTION AND RESTORATION AUTHORITY 150 TERRACE AVENUE BATON ROUGE, LOUISIANA 70802</p>		REV.	DATE	BY
<p>WEST MARSH CREATION AREA LAYOUT</p>		<p>DESIGNED BY: T. MCLAIN, E.I. APPROVED BY: T. FITZGERALD, P.E. P.E. NO. 38153</p>		
<p>NORTHWEST TURTLE BAY MARSH CREATION PROJECT</p>		<p>STATE PROJECT NUMBER: BA-0125 DRAWN BY: K. CANTU</p>		
<p>DATE: DEC. 2018</p>		<p>SHEET 5 OF 79</p>		

QUANTITIES				
WEST MARSH CREATION AREA DISCHARGE ZONE	MAXIMUM MARSH FILL QUANTITY (CY)	CONSTRUCTION MARSH FILL TARGET/MINIMUM ELEVATION (FT NAVD 88)	VERTICAL TOLERANCE (FT)	MAXIMUM MARSH FILL ELEVATION (FT NAVD 88)
WEST 1	250,000	1.5	0.5	2.0
WEST 2	280,000	1.5	0.5	2.0
WEST 3	200,000	1.5	0.5	2.0
WEST 4	230,000	1.5	0.5	2.0

STATE OF LOUISIANA
 TYE E. FITZGERALD
 License No. 38153
 PROFESSIONAL ENGINEER
 IN
 CIVIL ENGINEERING
 12/12/2018

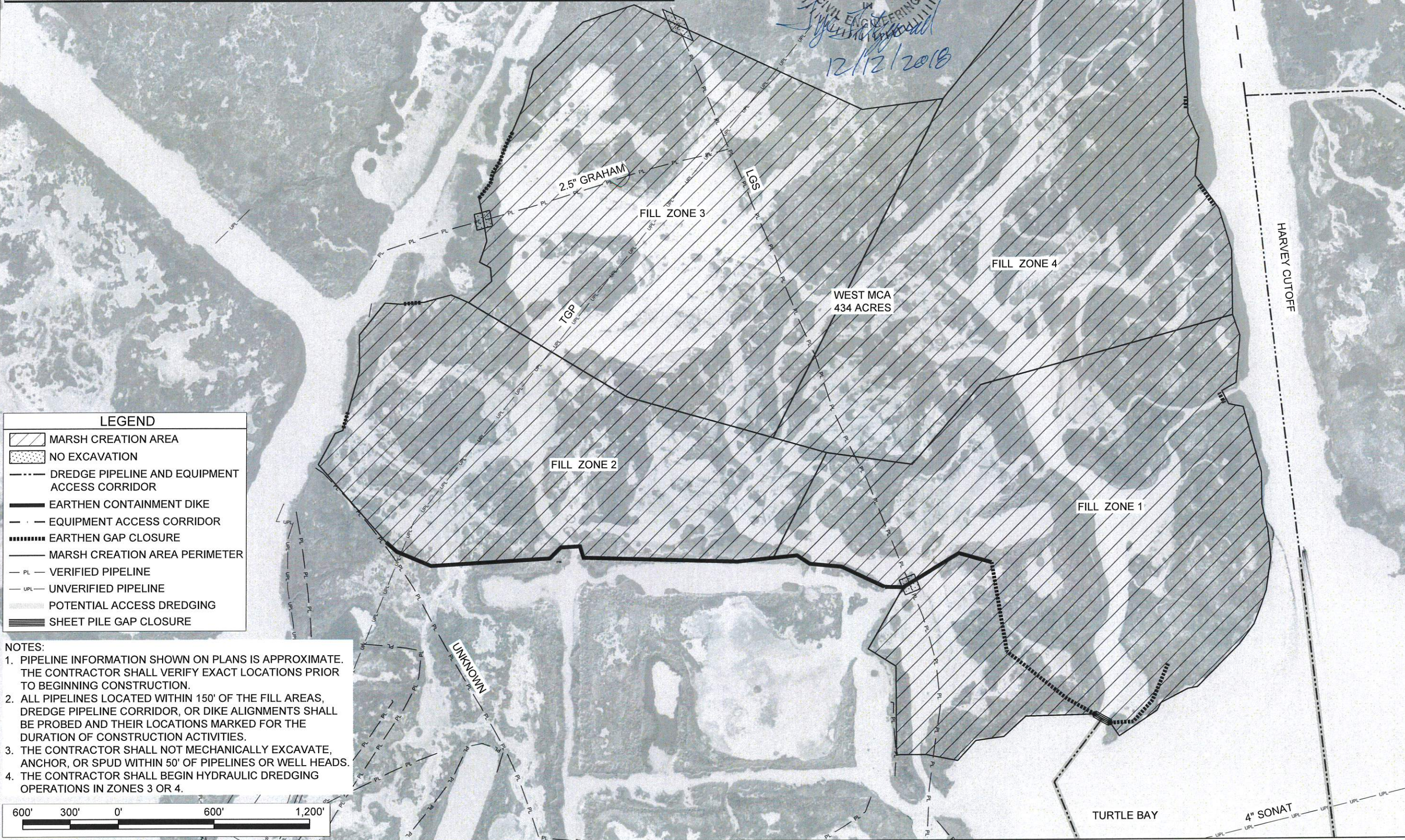

REV.	DATE	DESCRIPTION	BY

COASTAL PROTECTION AND RESTORATION AUTHORITY
 150 TERRACE AVENUE
 BATON ROUGE, LOUISIANA 70802

WEST MARSH CREATION AREA FILL ZONE LAYOUT
 DESIGNED BY: T. MCLAIN, E.I.
 APPROVED BY: T. FITZGERALD, P.E. P.E. NO. 38153

NORTHWEST TURTLE BAY MARSH CREATION PROJECT
 STATE PROJECT NUMBER: BA-0125
 DRAWN BY: K. CANTU

EAST MARSH CREATION PERIMETER COORDINATES

	NORTHING	EASTING		NORTHING	EASTING		NORTHING	EASTING		NORTHING	EASTING		NORTHING	EASTING		NORTHING	EASTING
1	390,258.04	3,664,140.20	12	390,358.09	3,670,155.40	23	389,902.93	3,671,674.41	34	388,684.76	3,670,895.83	45	387,920.42	3,667,691.34	56	388,333.54	3,665,798.59
2	390,278.21	3,667,294.70	13	390,356.66	3,670,256.07	24	389,872.56	3,671,614.34	35	388,450.37	3,670,760.65	46	387,947.22	3,667,641.68	57	388,332.71	3,665,548.83
3	390,275.74	3,667,515.28	14	390,341.76	3,670,600.14	25	389,881.06	3,671,551.68	36	388,250.95	3,670,626.76	47	387,983.60	3,667,602.35	58	388,509.32	3,665,264.77
4	390,287.46	3,667,618.77	15	390,357.41	3,671,025.88	26	389,881.83	3,671,497.52	37	388,156.47	3,670,478.26	48	388,027.39	3,667,406.77	59	388,485.75	3,665,196.16
5	390,286.87	3,668,268.34	16	390,370.60	3,671,816.78	27	389,882.13	3,671,449.42	38	387,846.08	3,670,289.04	49	388,032.50	3,667,151.00	60	388,524.82	3,664,819.52
6	390,310.31	3,668,754.30	17	390,219.98	3,671,832.25	28	389,828.02	3,671,415.90	39	387,659.27	3,670,033.14	50	388,005.09	3,667,055.61	61	388,640.99	3,664,671.46
7	390,306.65	3,669,011.27	18	390,195.21	3,671,840.70	29	389,739.97	3,671,395.74	40	387,610.33	3,669,621.49	51	388,066.93	3,666,970.32	62	388,660.70	3,664,593.98
8	390,294.85	3,669,111.27	19	390,114.64	3,671,820.63	30	389,505.98	3,671,087.23	41	387,732.58	3,669,297.99	52	388,386.17	3,666,643.38	63	388,688.97	3,664,463.58
9	390,294.85	3,669,211.27	20	390,062.16	3,671,758.31	31	389,420.43	3,670,983.86	42	387,880.80	3,668,805.05	53	388,388.44	3,666,507.07	64	388,871.85	3,664,216.88
10	390,337.65	3,669,461.27	21	389,986.98	3,671,718.06	32	389,159.66	3,670,918.56	43	387,856.81	3,668,452.47	54	388,250.39	3,666,218.58	65	389,052.01	3,664,166.17
11	390,340.69	3,669,550.36	22	389,941.27	3,671,715.50	33	388,885.68	3,670,947.33	44	387,884.84	3,668,225.14	55	388,250.39	3,665,946.60	66	389,188.35	3,664,015.50

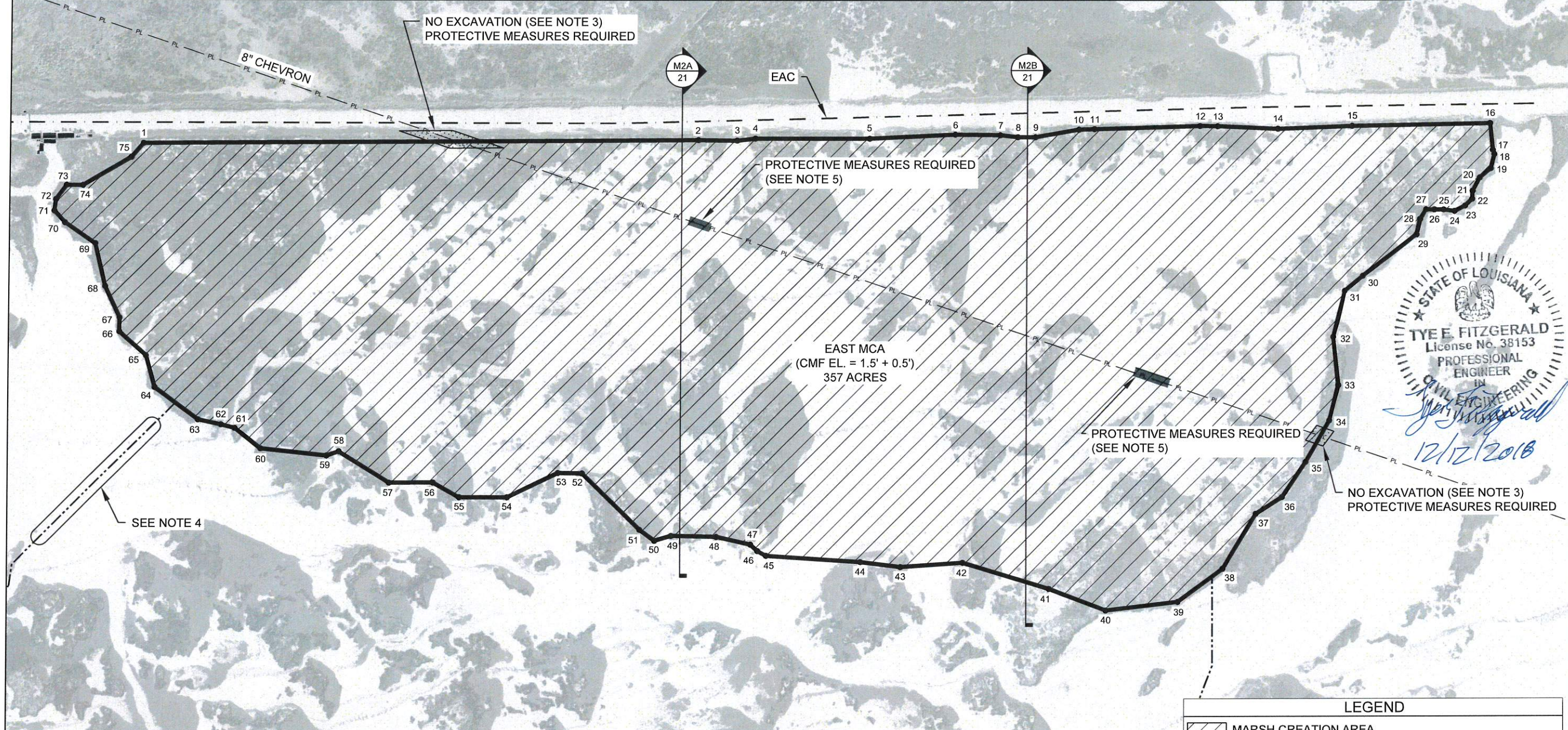

NOTES:

1. PIPELINE INFORMATION SHOWN ON PLANS IS APPROXIMATE. THE CONTRACTOR SHALL VERIFY EXACT LOCATIONS PRIOR TO BEGINNING CONSTRUCTION.
2. ALL PIPELINES LOCATED WITHIN 150' OF THE FILL AREAS, DREDGE PIPELINE CORRIDOR, OR DIKE ALIGNMENTS SHALL BE PROBED AND THEIR LOCATIONS MARKED FOR THE DURATION OF CONSTRUCTION ACTIVITIES.
3. THE CONTRACTOR SHALL NOT MECHANICALLY EXCAVATE, ANCHOR, OR SPUD WITHIN 50' OF PIPELINES.
4. THE CONTRACTOR SHALL PROVIDE A CROSSING CORRIDOR CAPABLE OF ACCOMMODATING SURFACE DRIVE BOATS.
5. PROTECTIVE MEASURES WILL BE REQUIRED AT ALL LOCATIONS WITH EQUIPMENT CROSSING EXISTING PIPELINES.

LEGEND

	MARSH CREATION AREA
	NO EXCAVATION
	DREDGE PIPELINE AND EQUIPMENT ACCESS CORRIDOR
	EARTHEN CONTAINMENT DIKE
	EQUIPMENT ACCESS CORRIDOR
	VERIFIED PIPELINE
	PROTECTIVE MEASURES REQUIRED

COASTAL PROTECTION AND RESTORATION AUTHORITY
 150 TERRACE AVENUE
 BATON ROUGE, LOUISIANA 70802

EAST MARSH CREATION AREA LAYOUT

DESIGNED BY: T. MCLAIN, E.I.
 APPROVED BY: T. FITZGERALD, P.E. P.E. NO. 38153

NORTHWEST TURTLE BAY MARSH CREATION PROJECT

STATE PROJECT NUMBER: BA-0125
 DRAWN BY: K. CANTU

DATE: DEC. 2018
 SHEET 7 OF 79

REV.	DATE	DESCRIPTION	BY

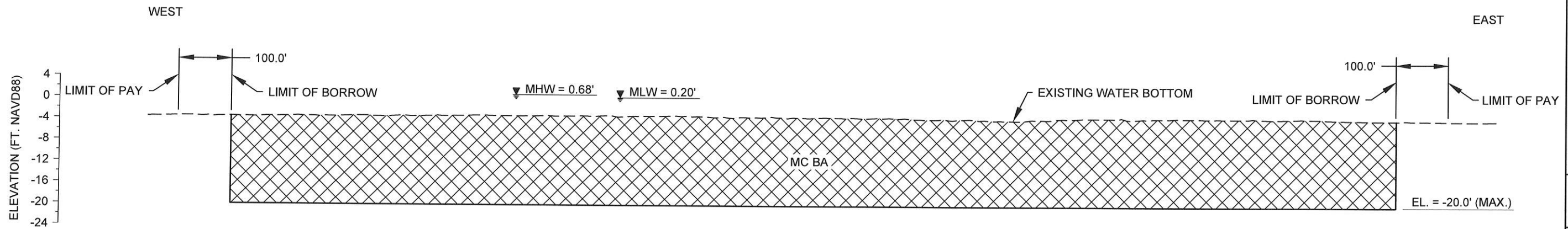

BA
4
TYPICAL SECTION - MARSH CREATION BORROW AREA

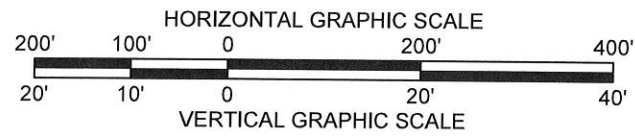

COASTAL PROTECTION AND RESTORATION AUTHORITY
150 TERRACE AVENUE
BATON ROUGE, LOUISIANA 70802

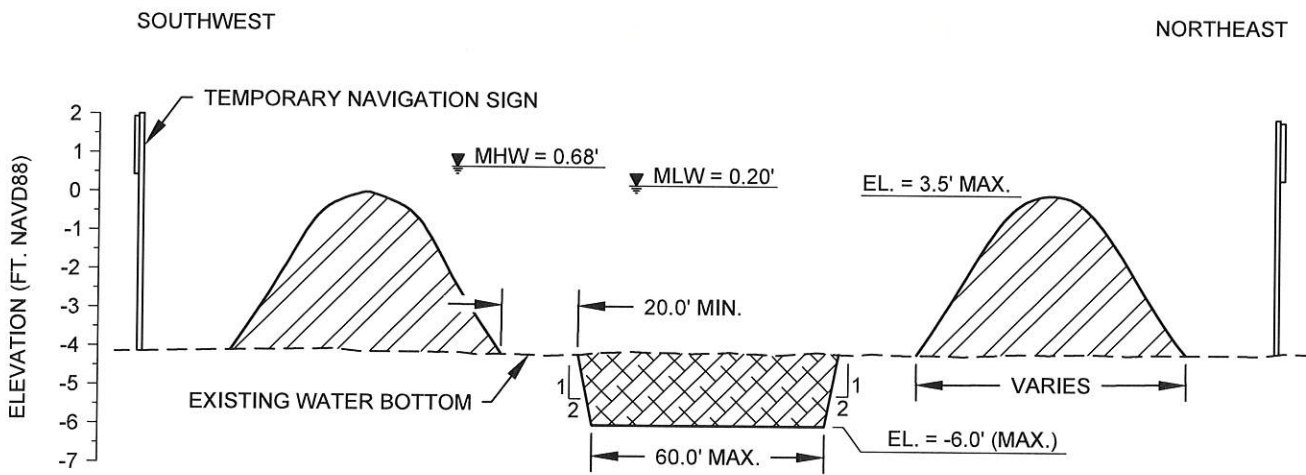

AD1
4
TYPICAL SECTION - WEST ACCESS DREDGING

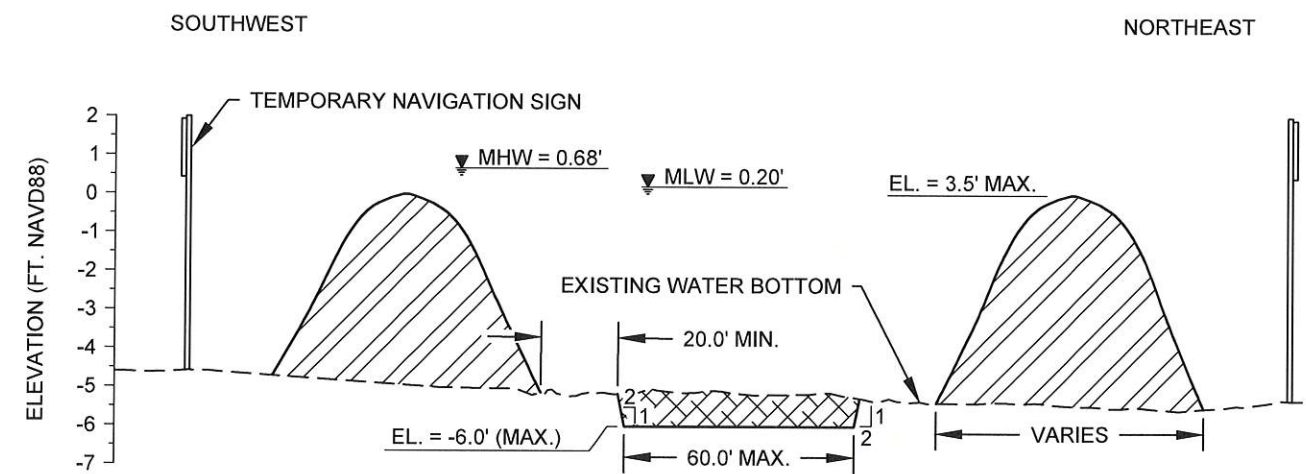

AD2
4
TYPICAL SECTION - EAST ACCESS DREDGING

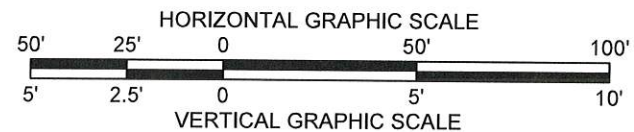

NOTE:
THE TEMPORARY SPOIL SHALL BE BACKFILLED PRIOR TO PROJECT COMPLETION LEAVING THE WATER BOTTOM NO HIGHER THAN 0.5' OF PRE-CONSTRUCTION ELEVATIONS.

LEGEND	
	BORROW AREA
	POTENTIAL ACCESS DREDGING
	TEMPORARY SPOIL
	WATER BOTTOM

MARSH CREATION BORROW AREA AND ACCESS DREDGING TYPICAL SECTIONS
DESIGNED BY: T. MCLAIN, E.I.
APPROVED BY: T. FITZGERALD, P.E. P.E. NO. 38153

NORTHWEST TURTLE BAY MARSH CREATION PROJECT
STATE PROJECT NUMBER: BA-0125
DRAWN BY: K. CANTU

REV.	DATE	DESCRIPTION	BY

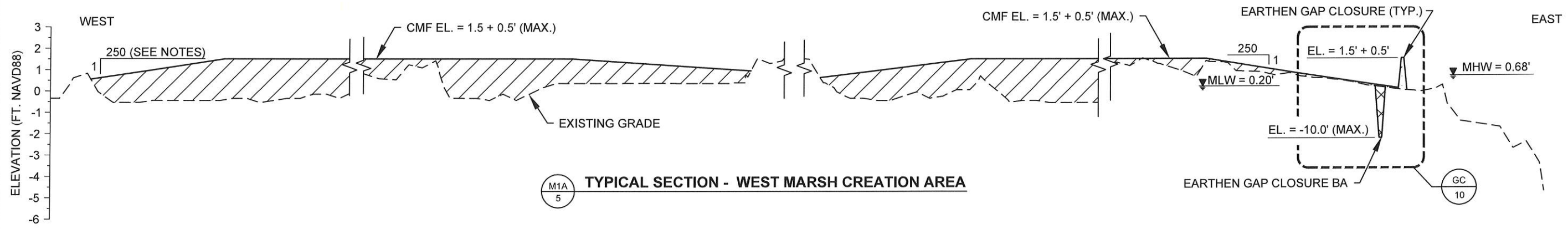

M1A
5
TYPICAL SECTION - WEST MARSH CREATION AREA

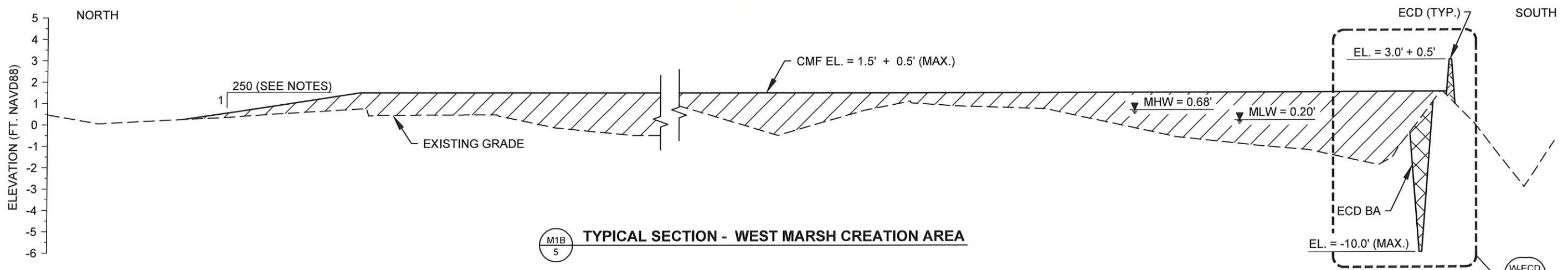

M1B
5
TYPICAL SECTION - WEST MARSH CREATION AREA

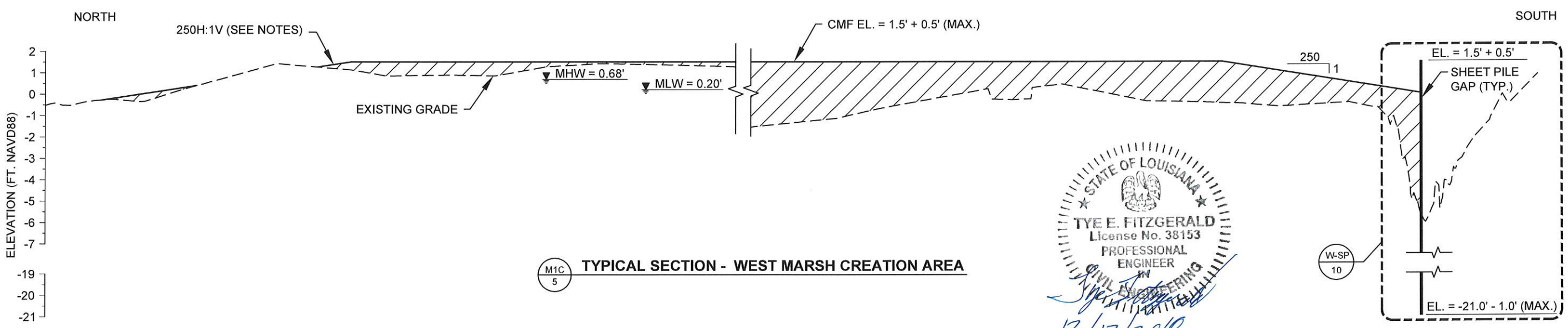

M1C
5
TYPICAL SECTION - WEST MARSH CREATION AREA

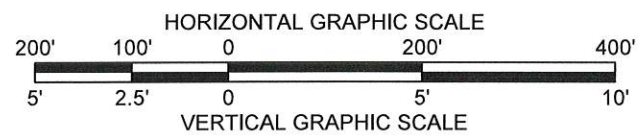

- NOTES:
 1. 1:250 SIDE SLOPES ARE AN APPROXIMATION.
 2. OTHER SIDE SLOPES MAY BE ACCEPTED BASED ON FIELD OBSERVATIONS.

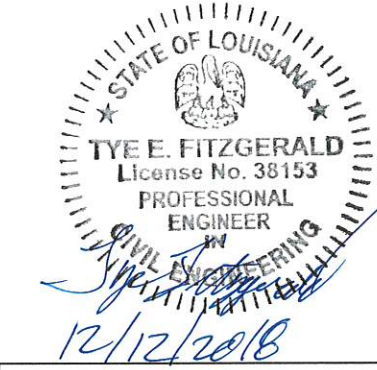

LEGEND	
	EARTHEN CONTAINMENT DIKE
	MARSH CREATION FILL
	EXISTING GRADE
	EARTHEN GAP CLOSURE
	ECD AND GC BORROW AREA

COASTAL PROTECTION AND RESTORATION AUTHORITY 150 TERRACE AVENUE BATON ROUGE, LOUISIANA 70802	
WEST MARSH CREATION AREA TYPICAL SECTIONS	DESIGNED BY: T. MCCLAIN, E.I. APPROVED BY: T. FITZGERALD, P.E. P.E. NO. 38153
NORTHWEST TURTLE BAY MARSH CREATION PROJECT	STATE PROJECT NUMBER: BA-A-0125 DRAWN BY: K. CANTU
DATE: DEC. 2018	
SHEET 9 OF 79	

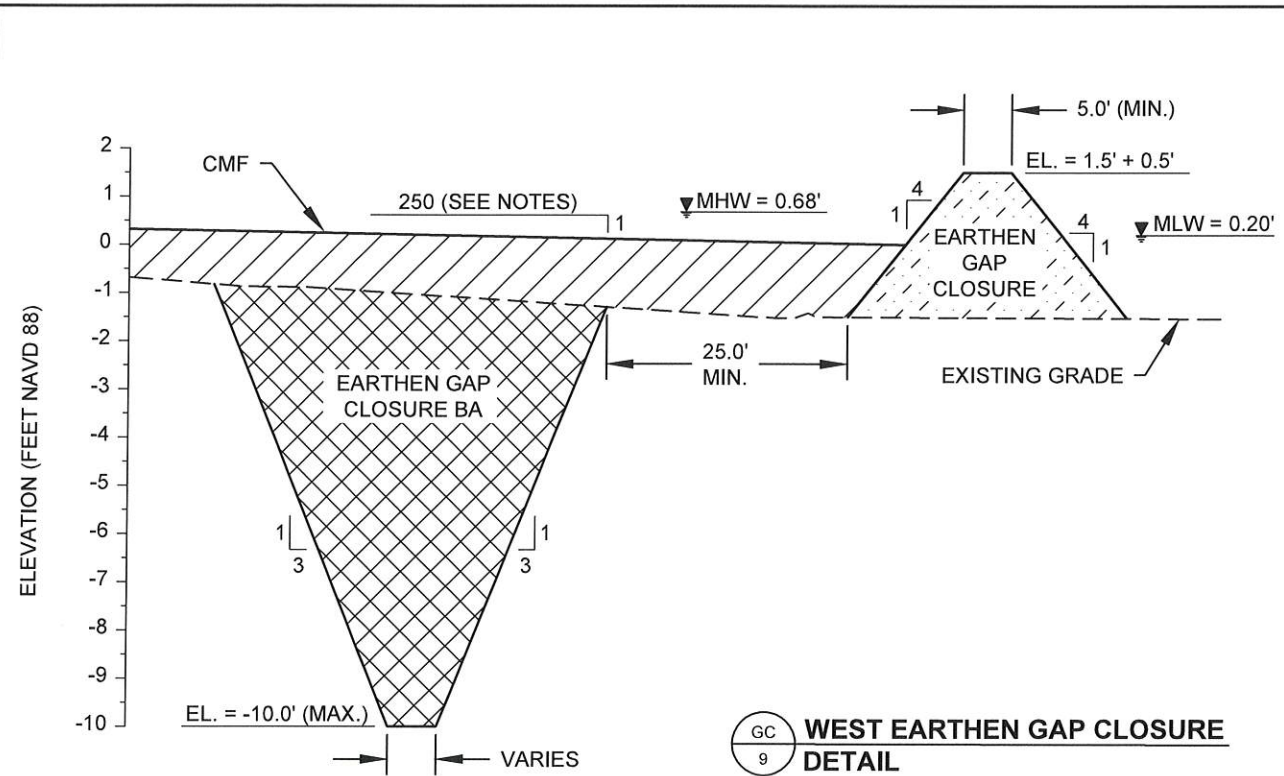

GC 9 WEST EARTHEN GAP CLOSURE DETAIL

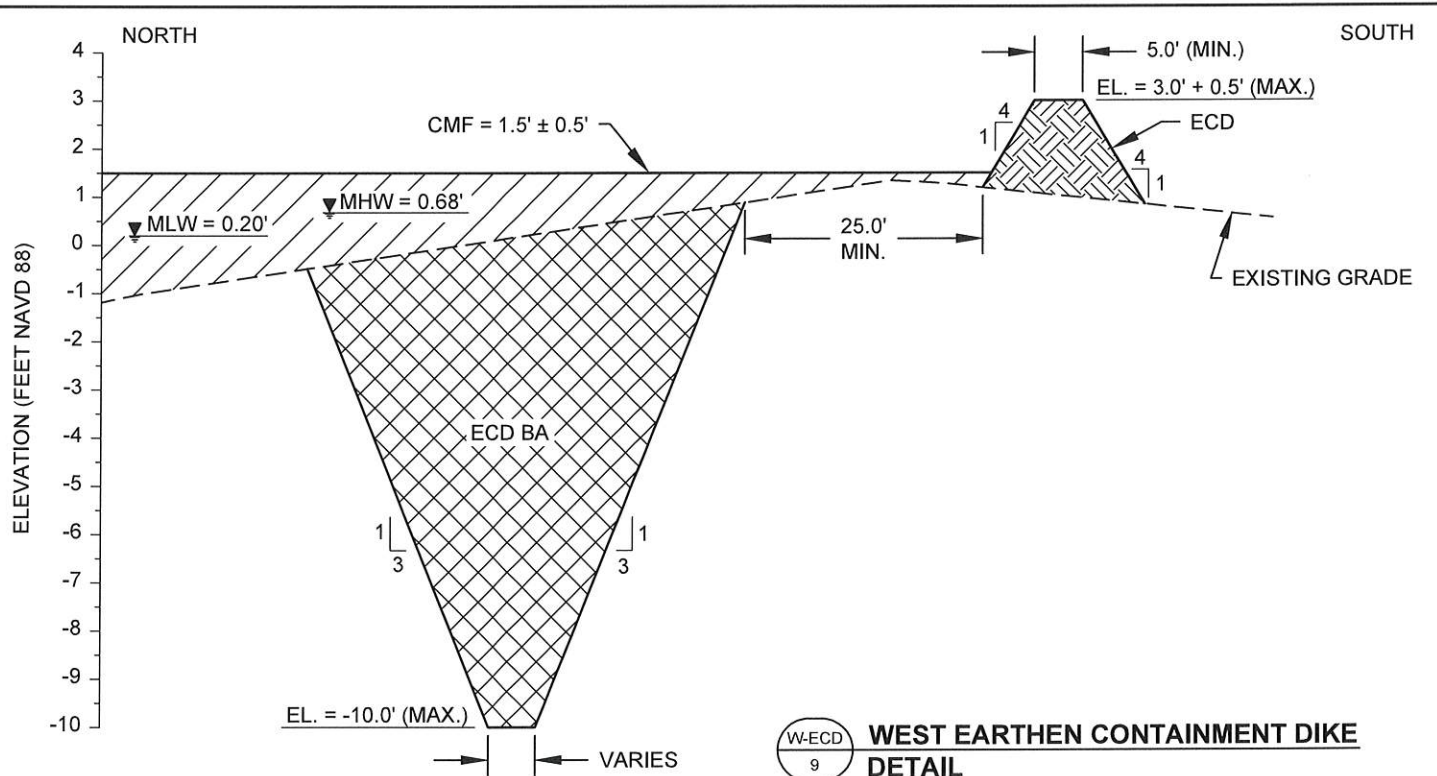

W-ECD 9 WEST EARTHEN CONTAINMENT DIKE DETAIL

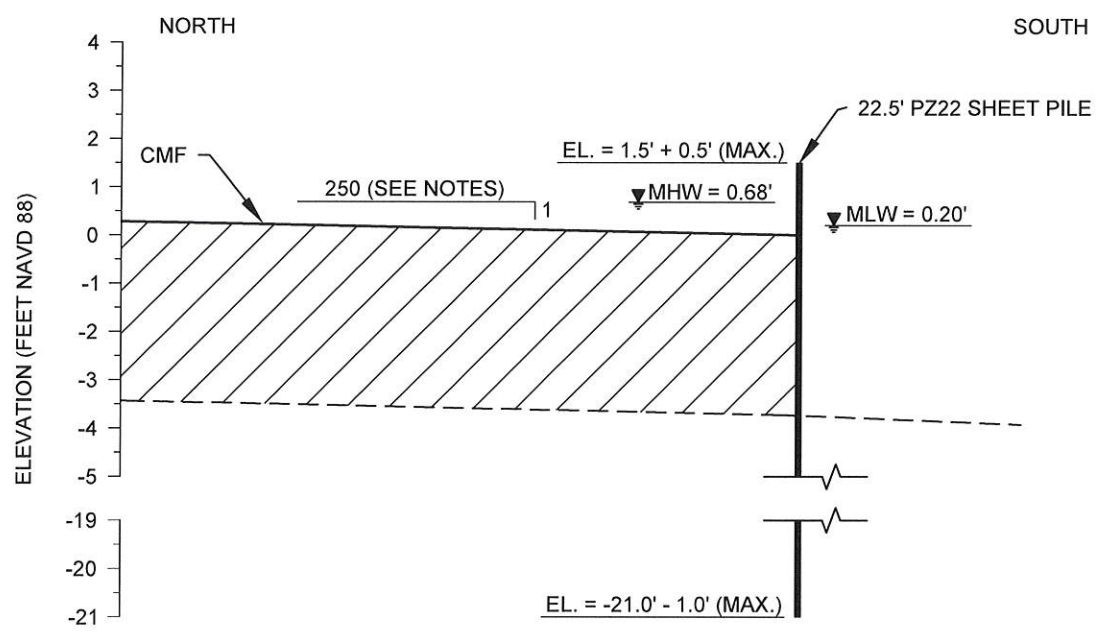

SP 9 WEST SHEET PILE GAP CLOSURE DETAIL

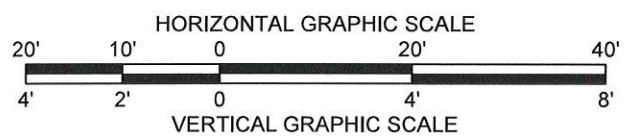

- NOTES:
 1. 1:250 SIDE SLOPES ARE AN APPROXIMATION.
 2. OTHER SIDE SLOPES MAY BE ACCEPTED BASED ON FIELD OBSERVATIONS.



LEGEND	
	EARTHEN CONTAINMENT DIKE
	EARTHEN GAP CLOSURE
	ECD AND EGC BORROW AREA
	MARSH CREATION FILL
	EXISTING GRADE

COASTAL PROTECTION AND RESTORATION AUTHORITY 150 TERRACE AVENUE BATON ROUGE, LOUISIANA 70802		REV.	DATE	DESCRIPTION	BY
WEST MARSH CREATION AREA DETAILS	DESIGNED BY: T. MCLAIN, E.I.				
APPROVED BY: T. FITZGERALD, P.E.	P.E. NO. 38153				
NORTHWEST TURTLE BAY MARSH CREATION PROJECT	STATE PROJECT NUMBER: BA-0125				
DRAWN BY: K. CANTU					
DATE: DEC. 2018					
SHEET 10 OF 79					

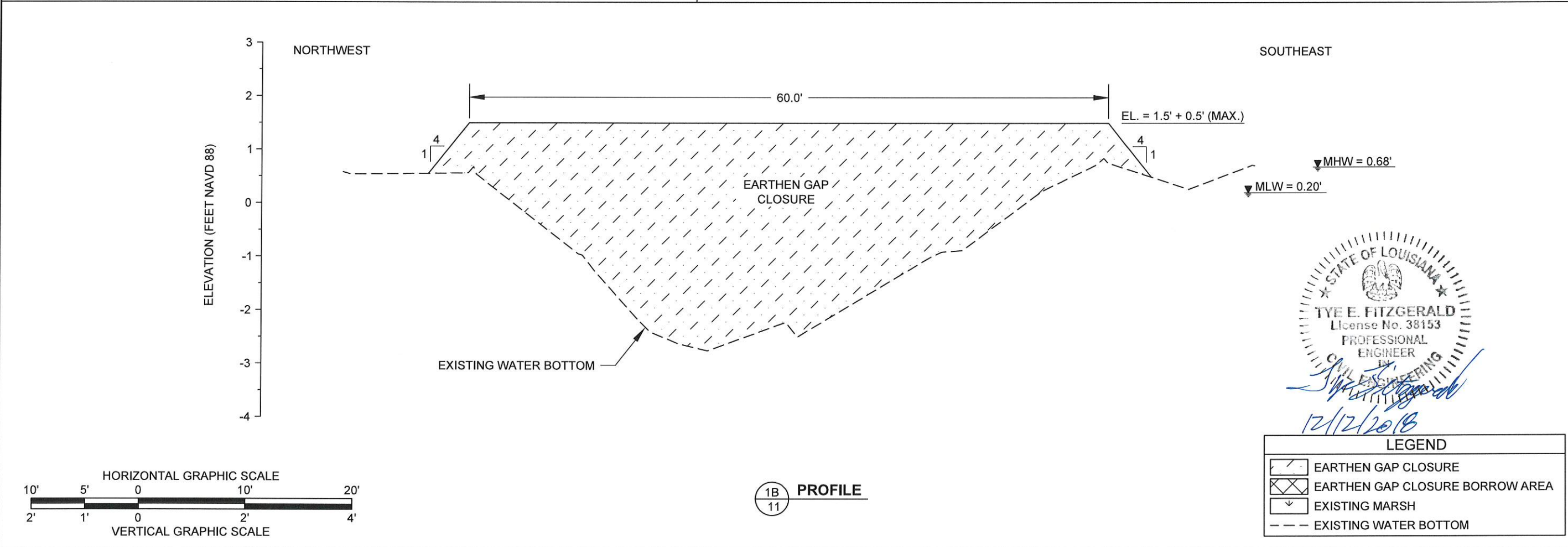
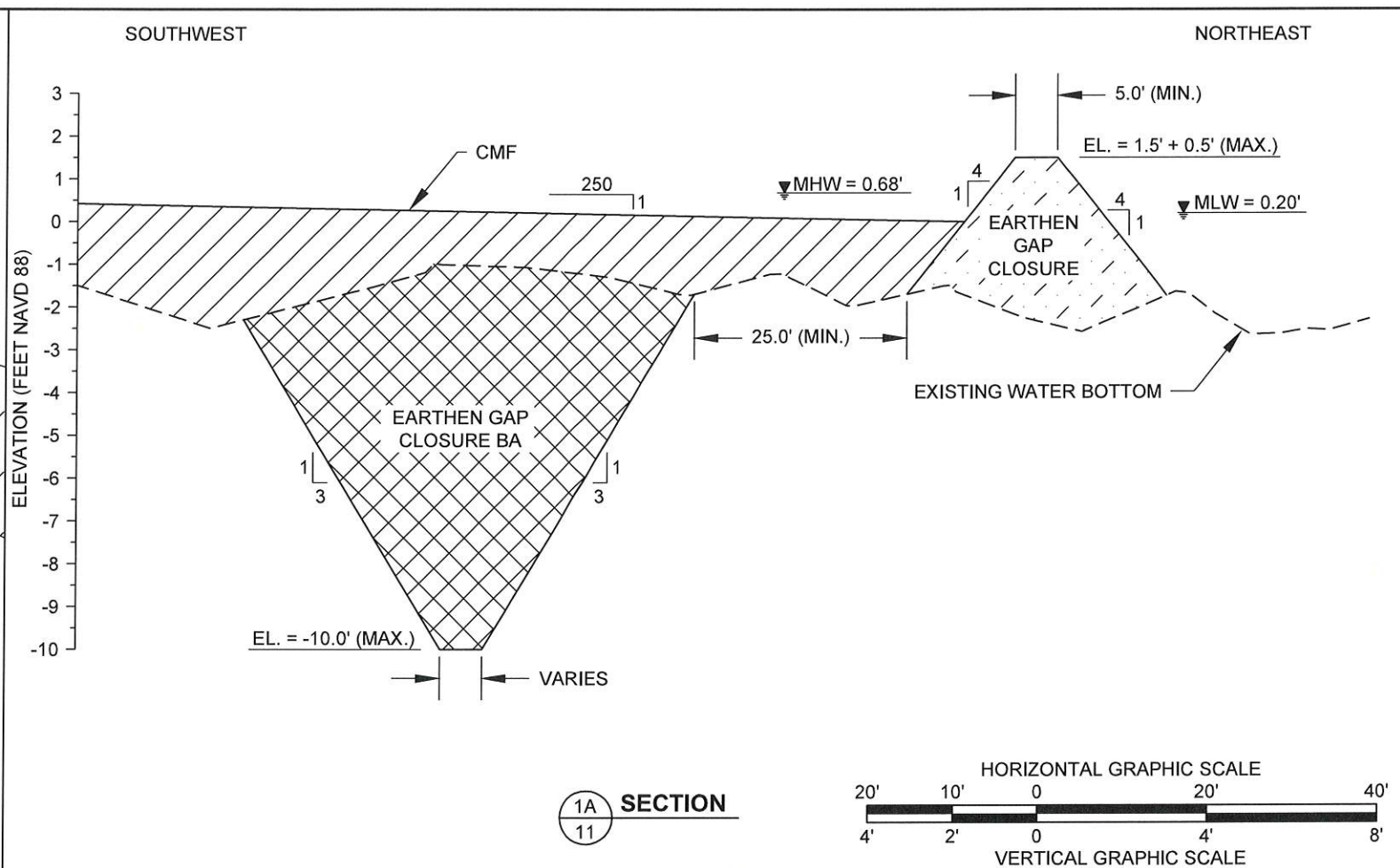
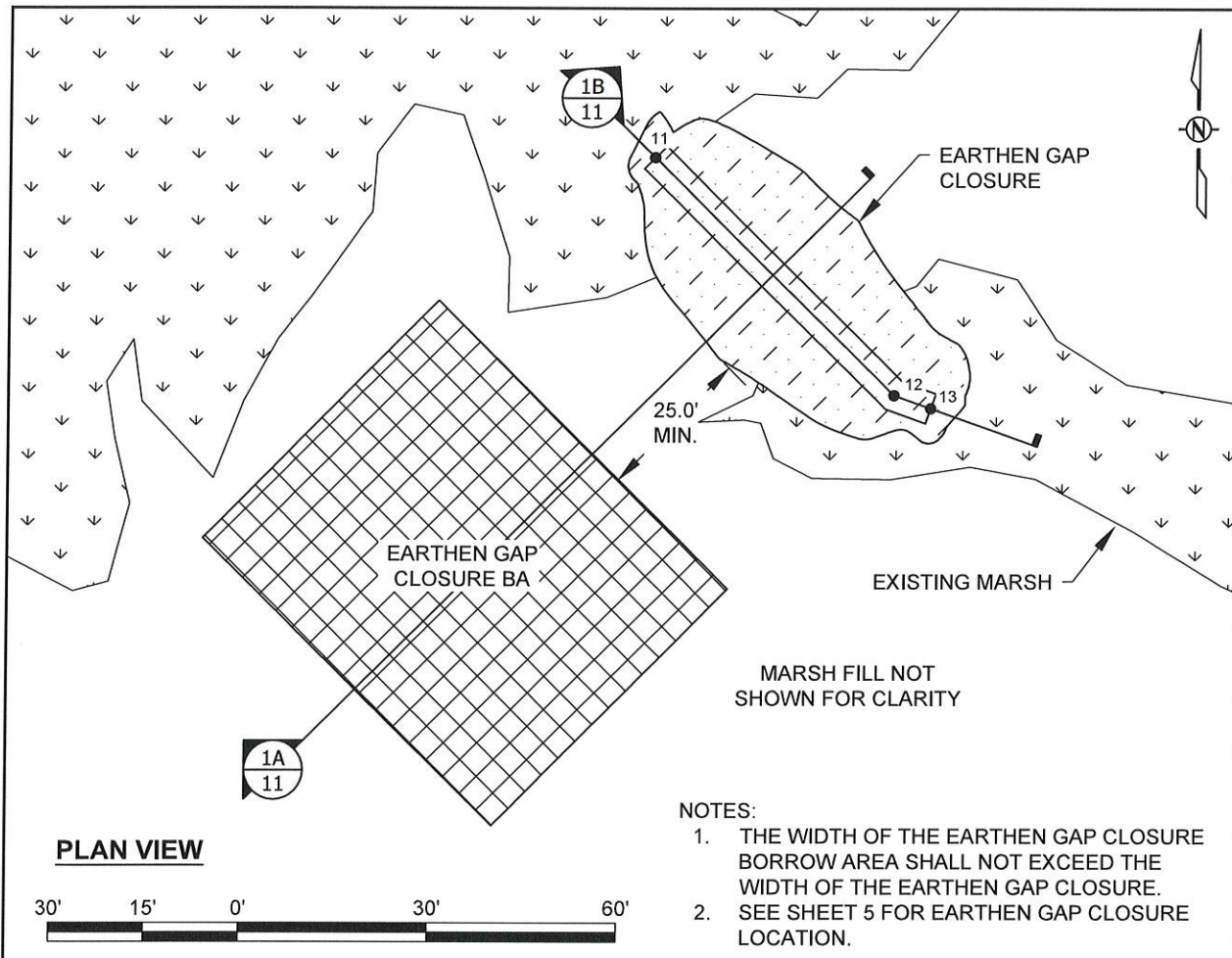

REV.	DATE	DESCRIPTION	BY

COASTAL PROTECTION AND RESTORATION AUTHORITY
 150 TERRACE AVENUE
 BATON ROUGE, LOUISIANA 70802

EARTHEN GAP CLOSURE 1
 PLAN, SECTION,
 AND PROFILE VIEWS

DESIGNED BY: T. MCLAIN, P.E.
 APPROVED BY: T. FITZGERALD, P.E.

NORTHWEST TURTLE BAY
 MARSH CREATION PROJECT

STATE PROJECT NUMBER: BA-0125
 DRAWN BY: K. CANTU

DATE: DEC. 2018

SHEET 11 OF 79

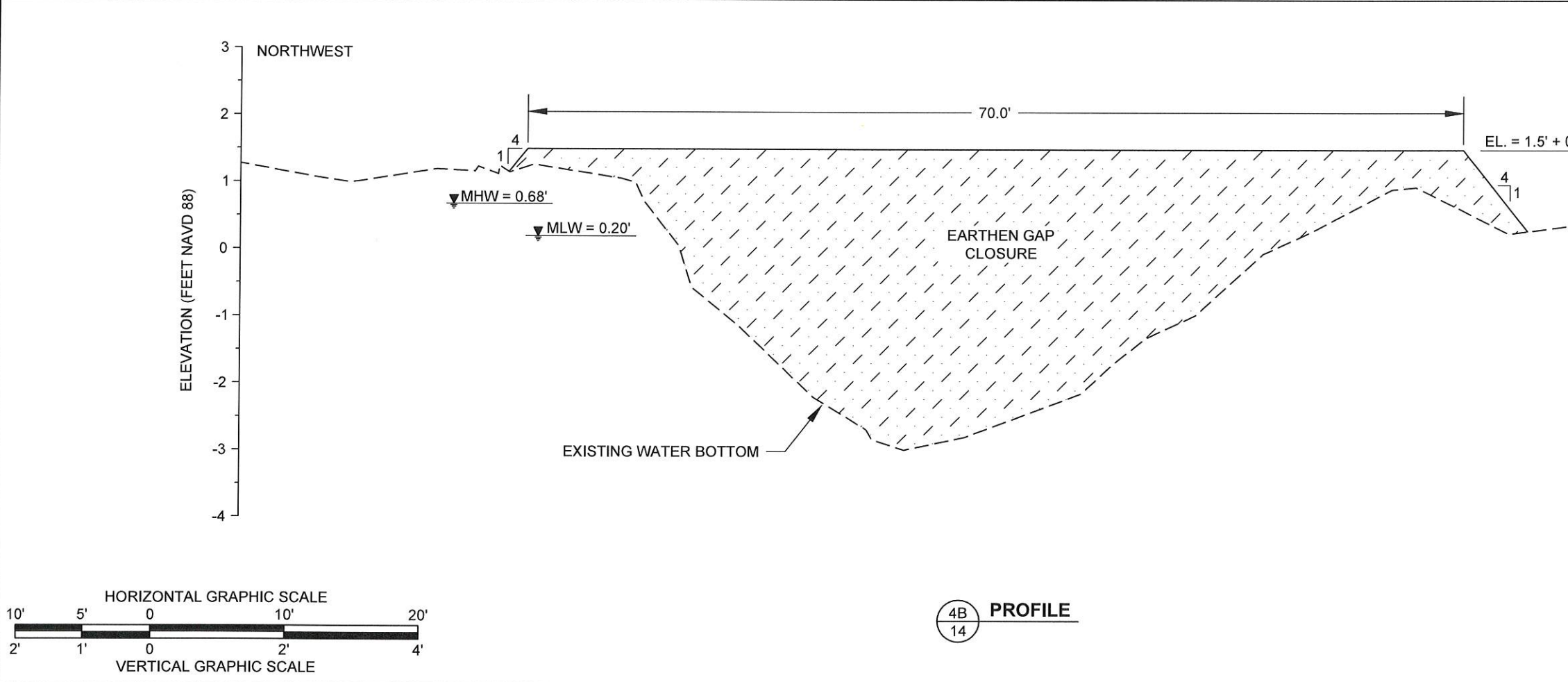
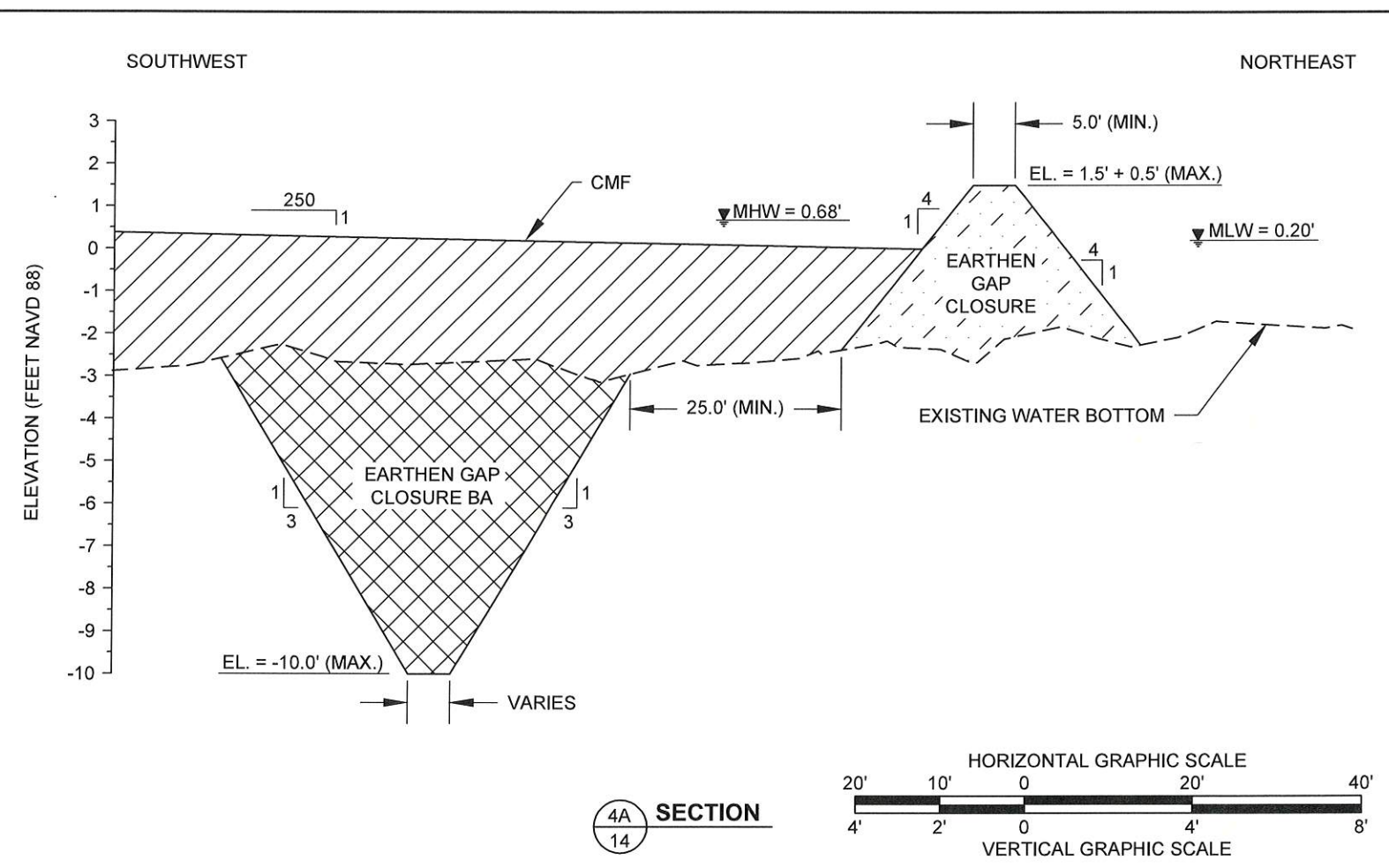
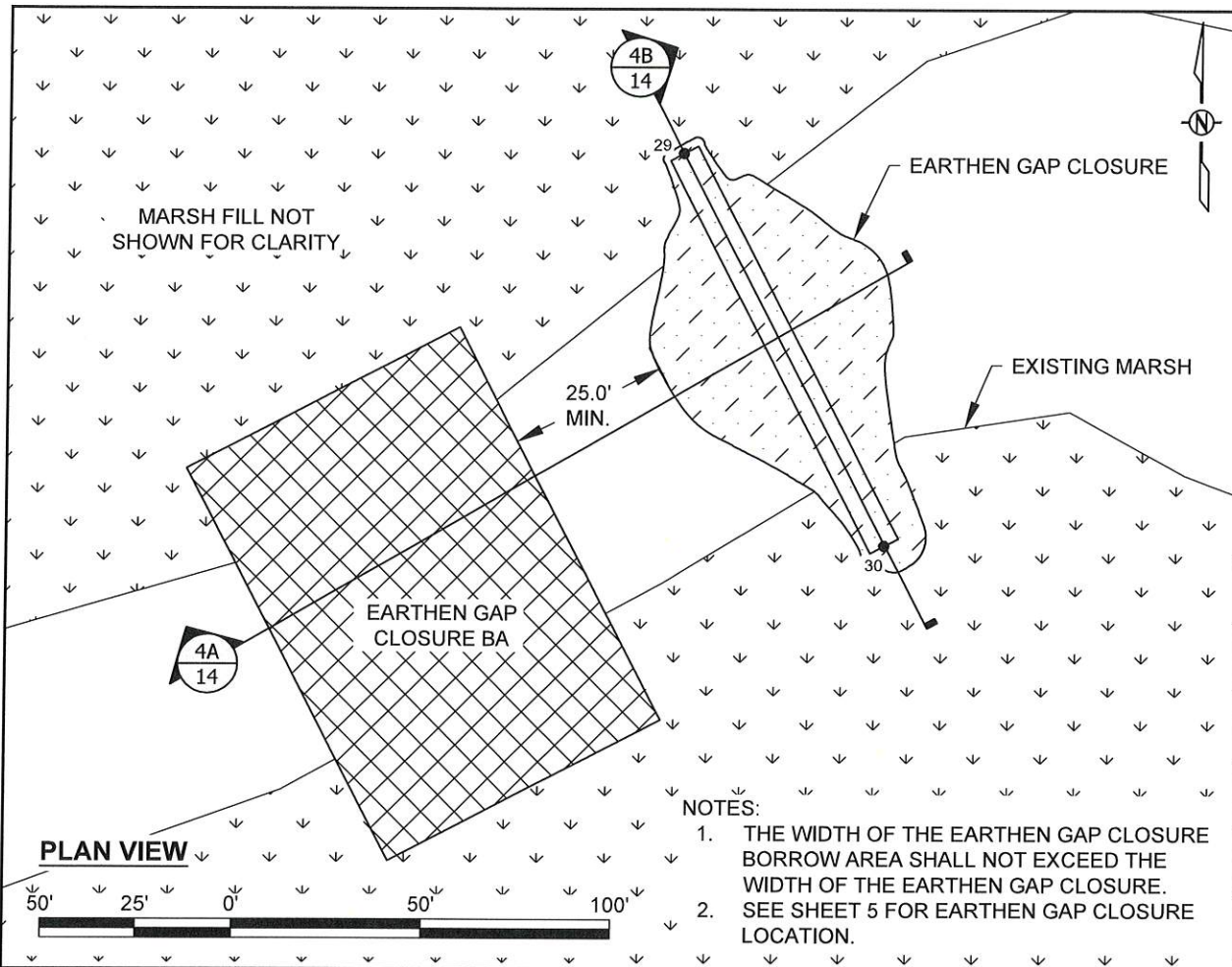

STATE OF LOUISIANA

TYE E. FITZGERALD
License No. 38153
PROFESSIONAL ENGINEER

12/12/2018

LEGEND

	EARTHEN GAP CLOSURE
	EARTHEN GAP CLOSURE BORROW AREA
	EXISTING MARSH
	EXISTING WATER BOTTOM

REV.	DATE	DESCRIPTION	BY

COASTAL PROTECTION AND RESTORATION AUTHORITY
150 TERRACE AVENUE
BATON ROUGE, LOUISIANA 70802

GAP CLOSURE 4 PLAN, SECTION, AND PROFILE VIEWS

DESIGNED BY: T. MCLAIN, P.E.
APPROVED BY: T. FITZGERALD, P.E.

NORTHWEST TURTLE BAY MARSH CREATION PROJECT

STATE PROJECT NUMBER: BA-0125
DRAWN BY: K. CANTU

DATE: DEC. 2018

SHEET 14 OF 79

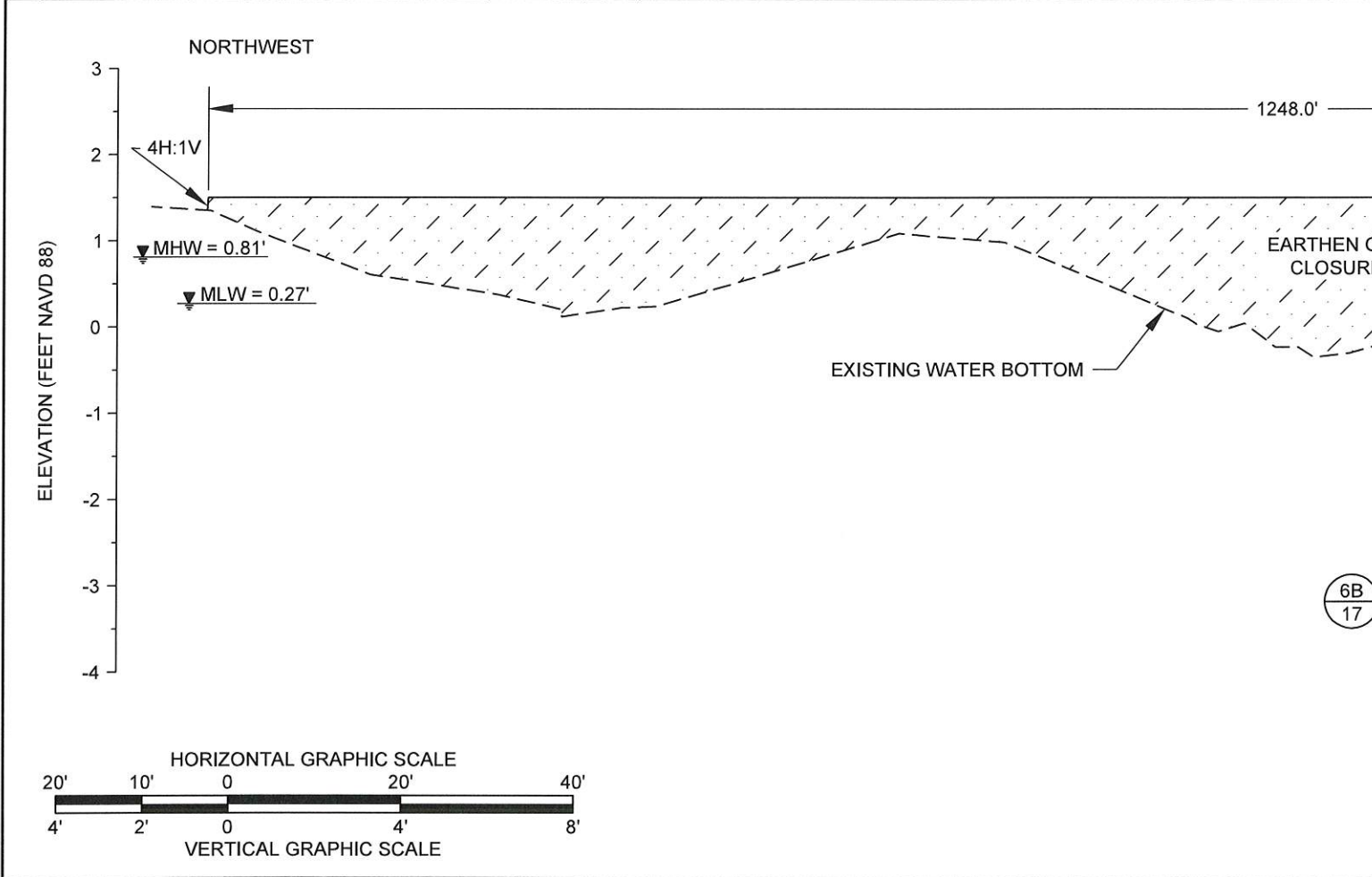
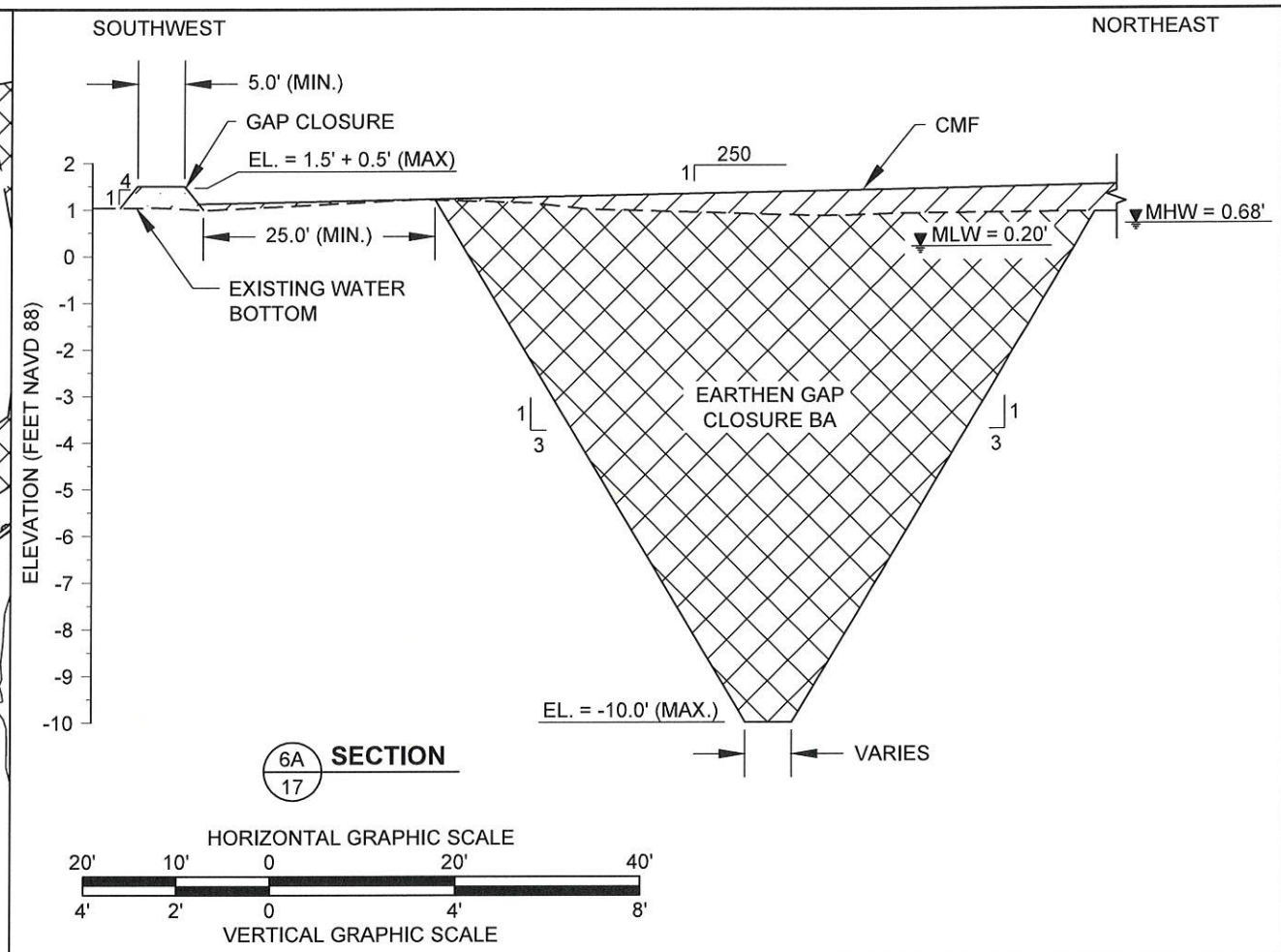
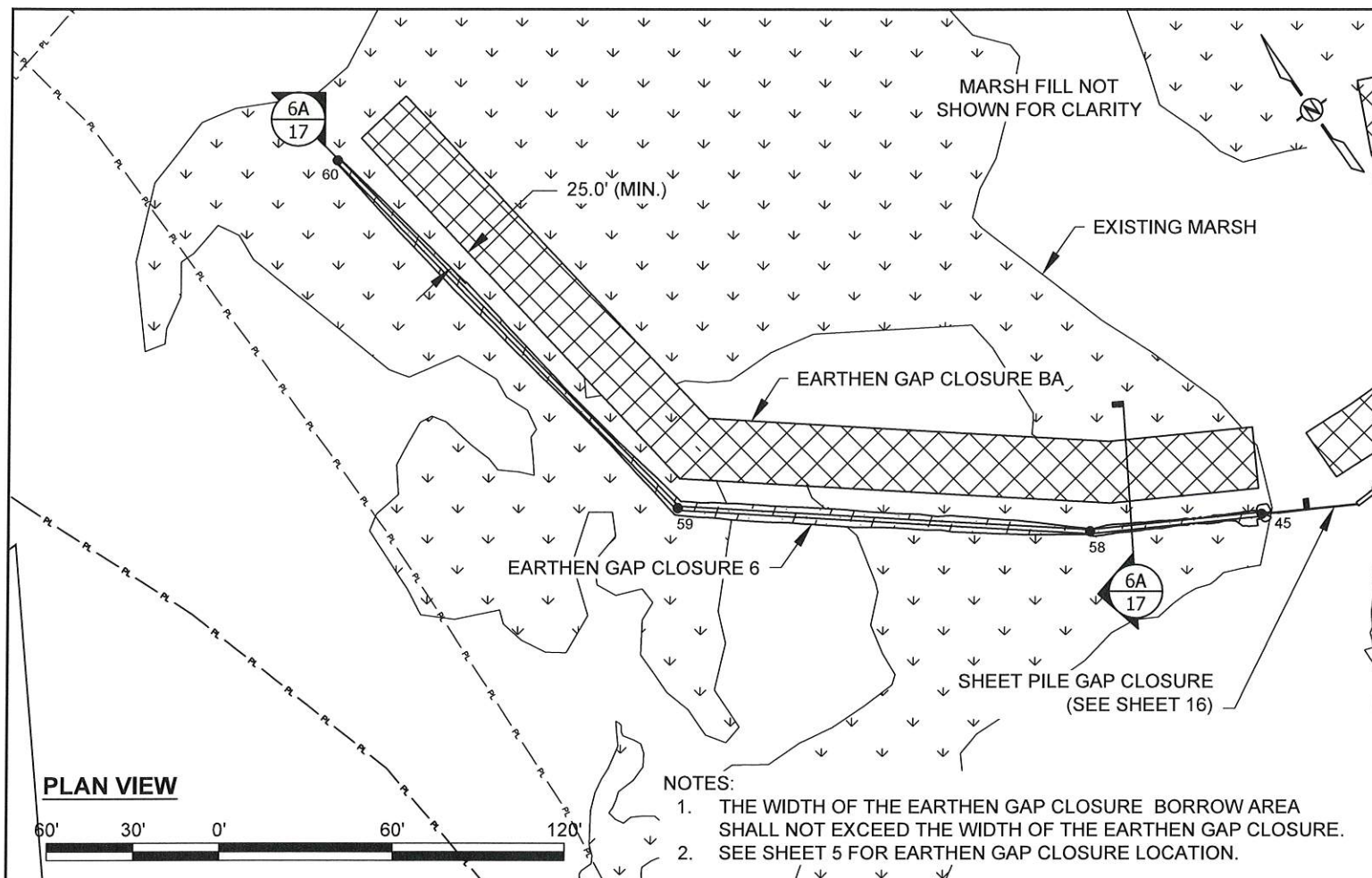

STATE OF LOUISIANA
 TYE E. FITZGERALD
 License No. 38153
 PROFESSIONAL ENGINEER
 CIVIL ENGINEERING
 12/12/2018

LEGEND	
	EARTHEN GAP CLOSURE
	EARTHEN GAP CLOSURE BORROW AREA
	EXISTING MARSH
	EXISTING WATER BOTTOM

REV.	DATE	DESCRIPTION	BY

COASTAL PROTECTION AND RESTORATION AUTHORITY
 150 TERRACE AVENUE
 BATON ROUGE, LOUISIANA 70802

EARTHEN GAP CLOSURE 6 PLAN, SECTION, AND PROFILE VIEWS	DESIGNED BY: T. MCLAIN, P.E. APPROVED BY: T. FITZGERALD, P.E.
NORTHWEST TURTLE BAY MARSH CREATION PROJECT	STATE PROJECT NUMBER: BA-0125 DRAWN BY: K. CANTU

DATE: DEC. 2018
 SHEET 17 OF 79

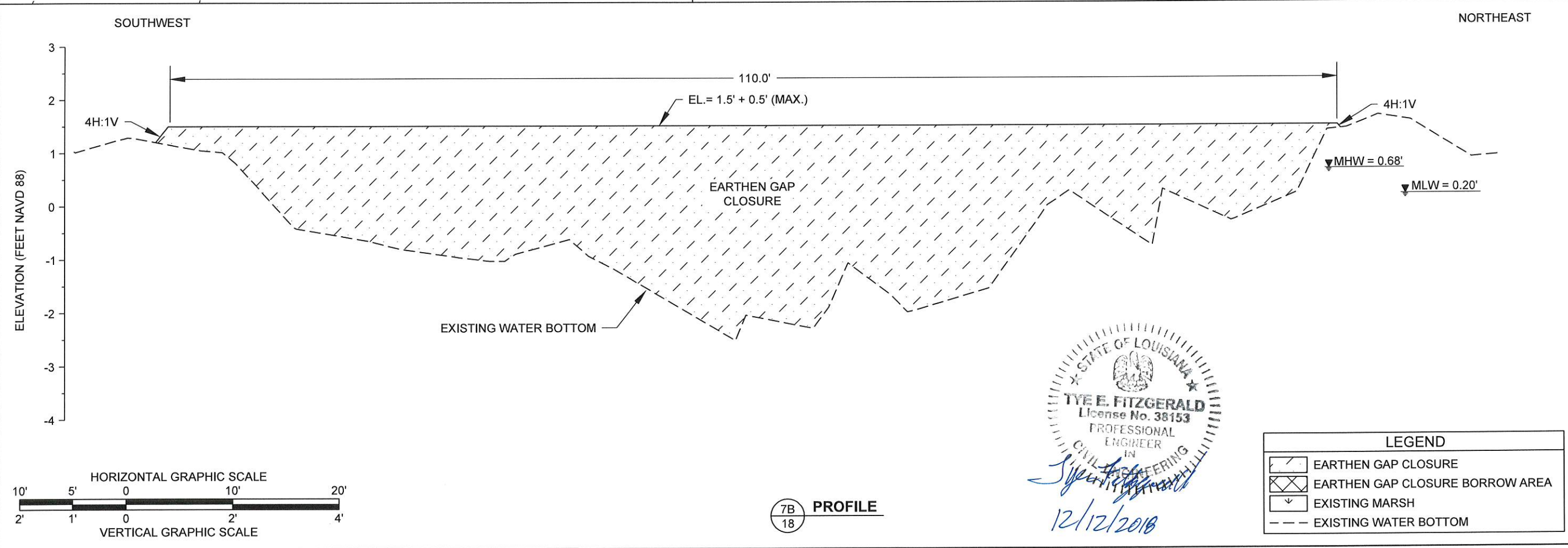
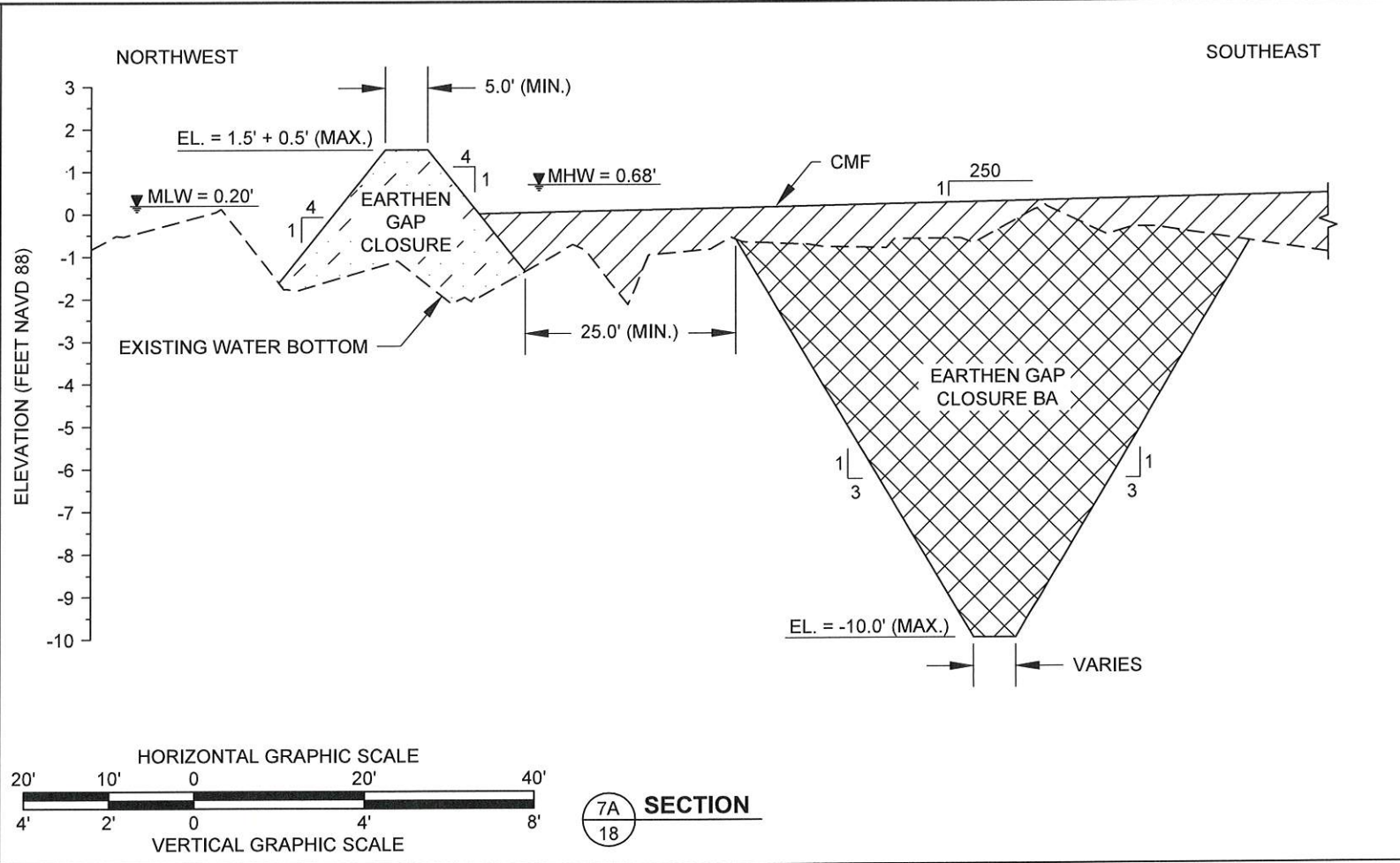
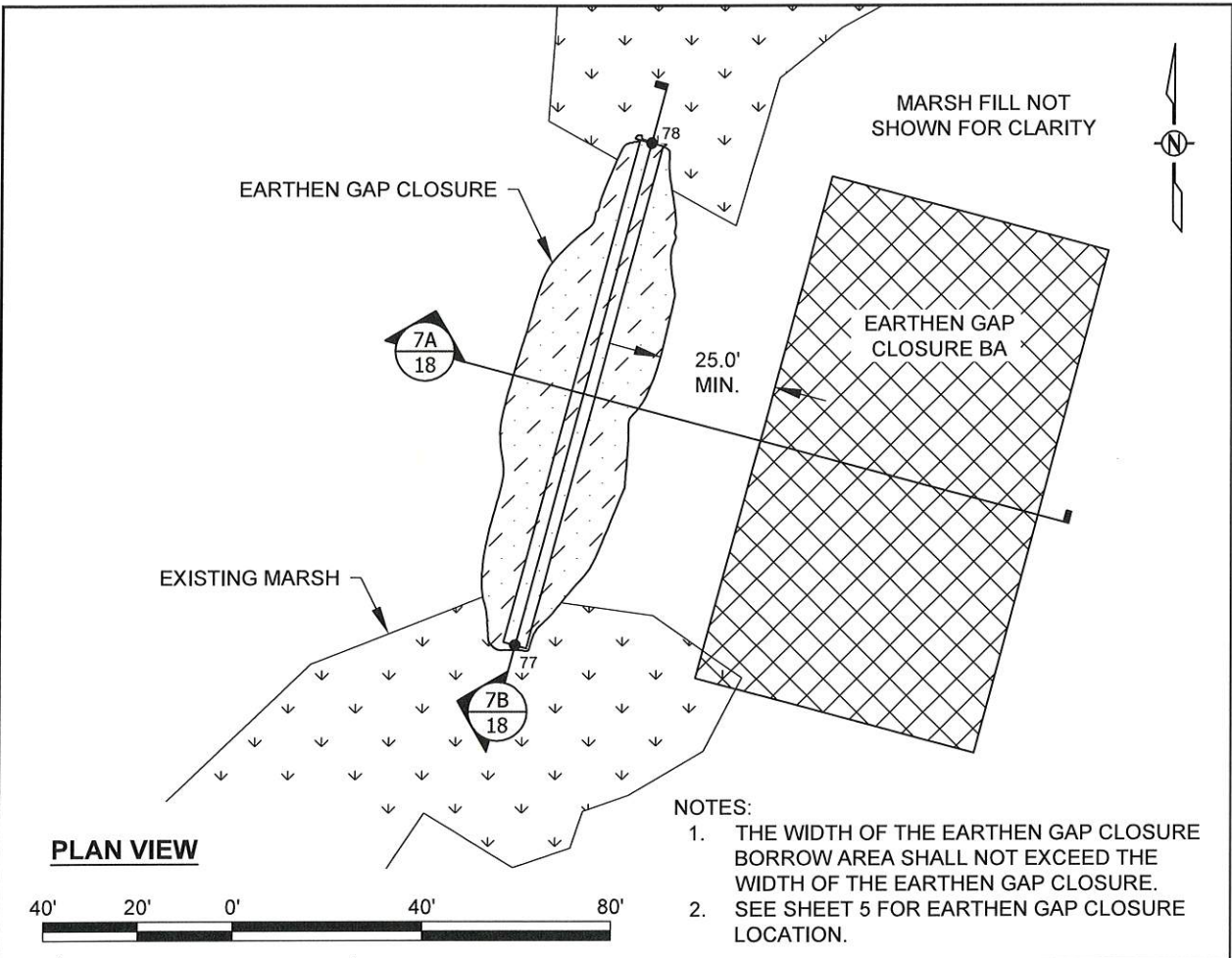

LEGEND	
	EARTHEN GAP CLOSURE
	EARTHEN GAP CLOSURE BORROW AREA
	EXISTING MARSH
	EXISTING WATER BOTTOM

STATE OF LOUISIANA
 TYE E. FITZGERALD
 License No. 38153
 PROFESSIONAL ENGINEER
 IN
 CIVIL ENGINEERING
Tye E. Fitzgerald
 12/12/2018

NO.	DATE	REVISION	DESCRIPTION	BY

COASTAL PROTECTION AND RESTORATION AUTHORITY
 150 TERRACE AVENUE
 BATON ROUGE, LOUISIANA 70802

EARTHEN GAP CLOSURE 7 PLAN, SECTION, AND PROFILE VIEWS

DESIGNED BY: T. MCLAIN, P.E.
 APPROVED BY: T. FITZGERALD, P.E.

NORTHWEST TURTLE BAY MARSH CREATION PROJECT

STATE PROJECT NUMBER: BA-0125
 DRAWN BY: K. CANTU

DATE: DEC. 2018
 SHEET 18 OF 79

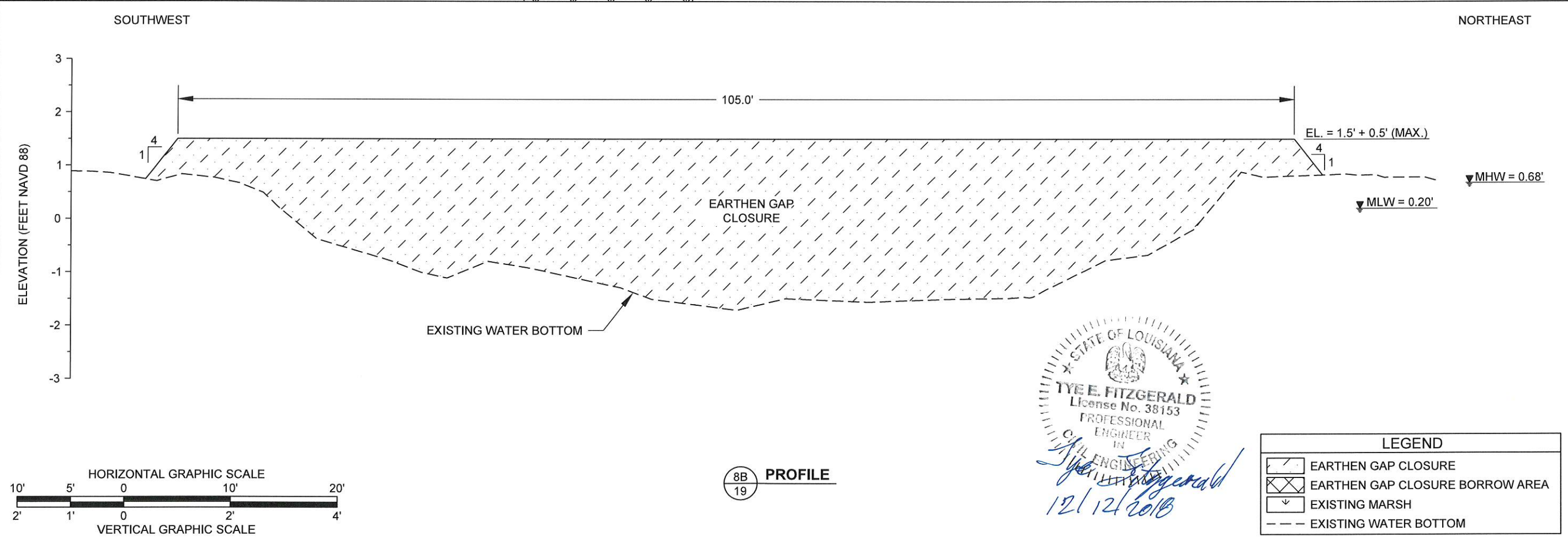
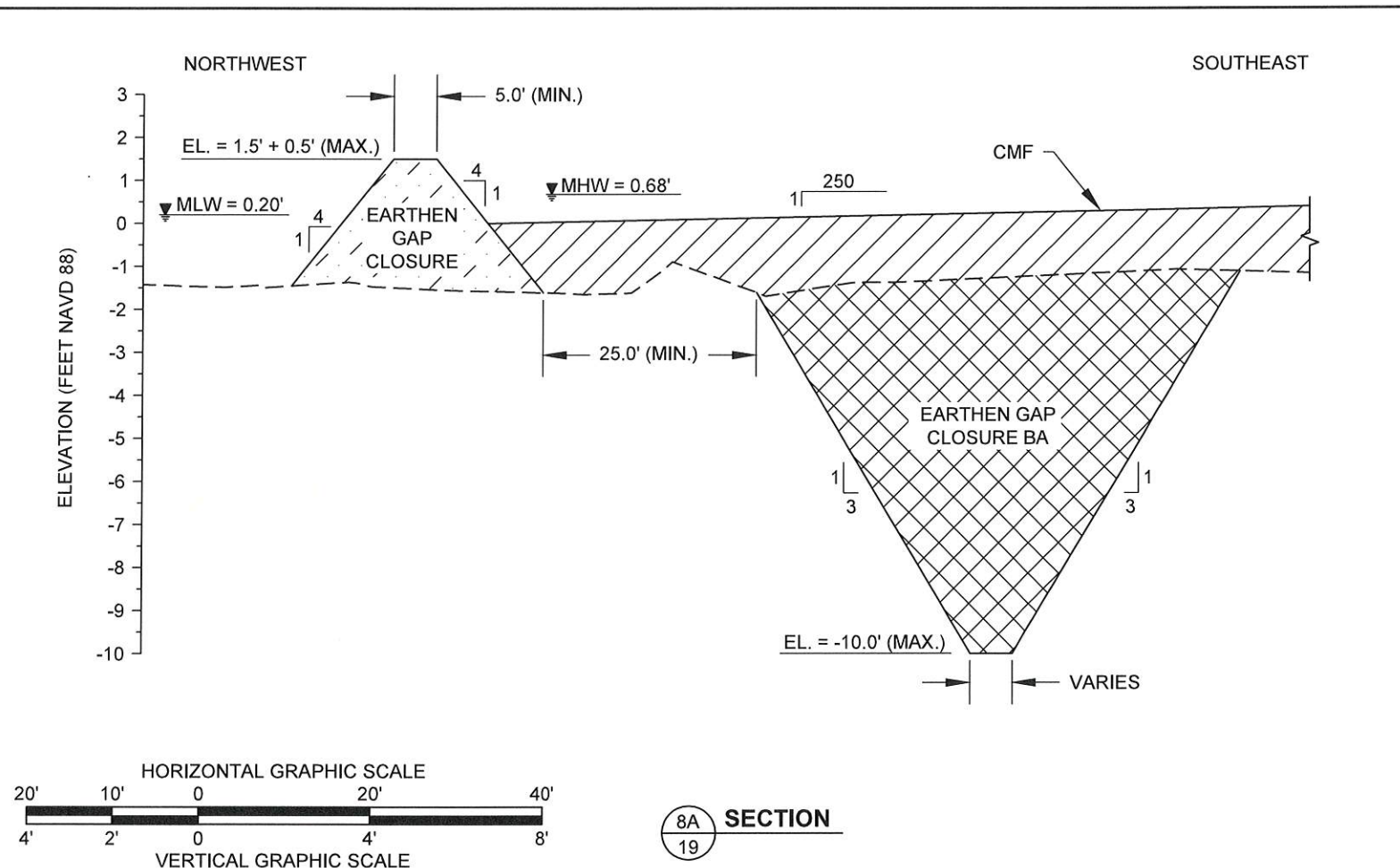
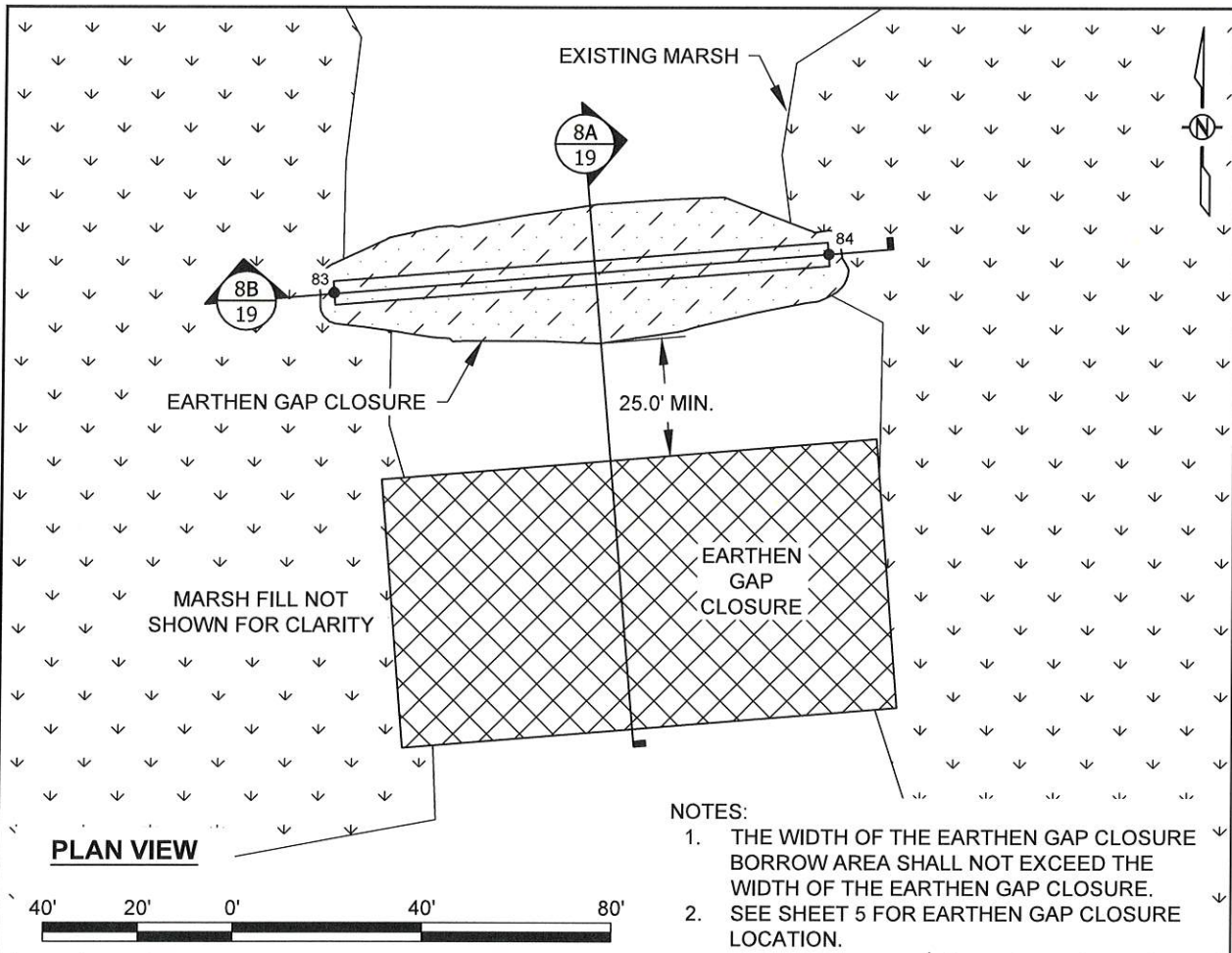

STATE OF LOUISIANA
 TYE E. FITZGERALD
 License No. 38153
 PROFESSIONAL ENGINEER
 IN
 CIVIL ENGINEERING
 12/12/2018

LEGEND	
	EARTHEN GAP CLOSURE
	EARTHEN GAP CLOSURE BORROW AREA
	EXISTING MARSH
	EXISTING WATER BOTTOM

REV.	DATE	DESCRIPTION	BY

COASTAL PROTECTION AND RESTORATION AUTHORITY
 150 TERRACE AVENUE
 BATON ROUGE, LOUISIANA 70802

EARTHEN GAP CLOSURE 8 PLAN, SECTION, AND PROFILE VIEWS

DESIGNED BY: T. MCLAIN, P.E.
 APPROVED BY: T. FITZGERALD, P.E.

NORTHWEST TURTLE BAY MARSH CREATION PROJECT

STATE PROJECT NUMBER: BA-0125
 DRAWN BY: K. CANTU

DATE: DEC. 2018
 SHEET 19 OF 79

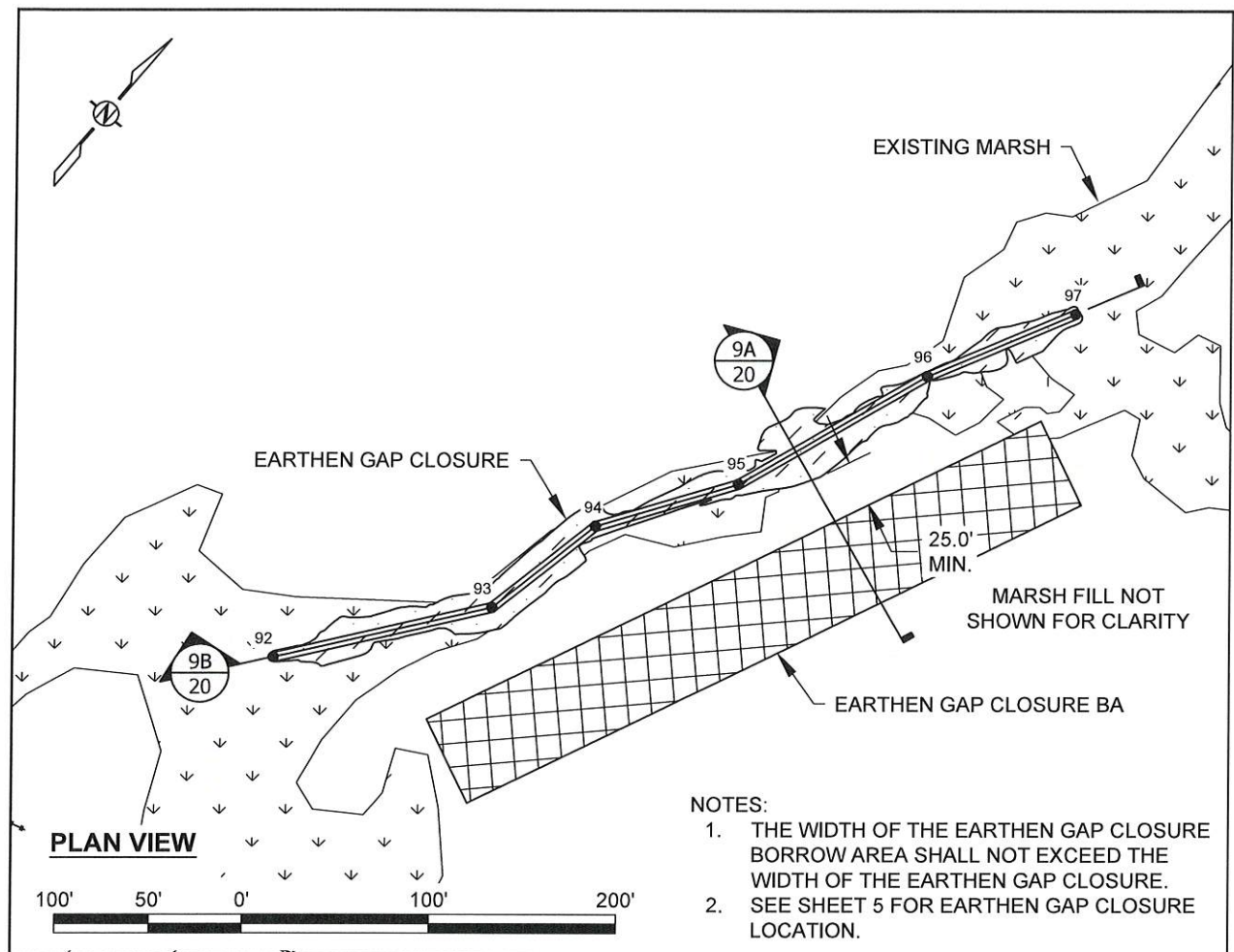

- NOTES:
1. THE WIDTH OF THE EARTHEN GAP CLOSURE BORROW AREA SHALL NOT EXCEED THE WIDTH OF THE EARTHEN GAP CLOSURE.
 2. SEE SHEET 5 FOR EARTHEN GAP CLOSURE LOCATION.

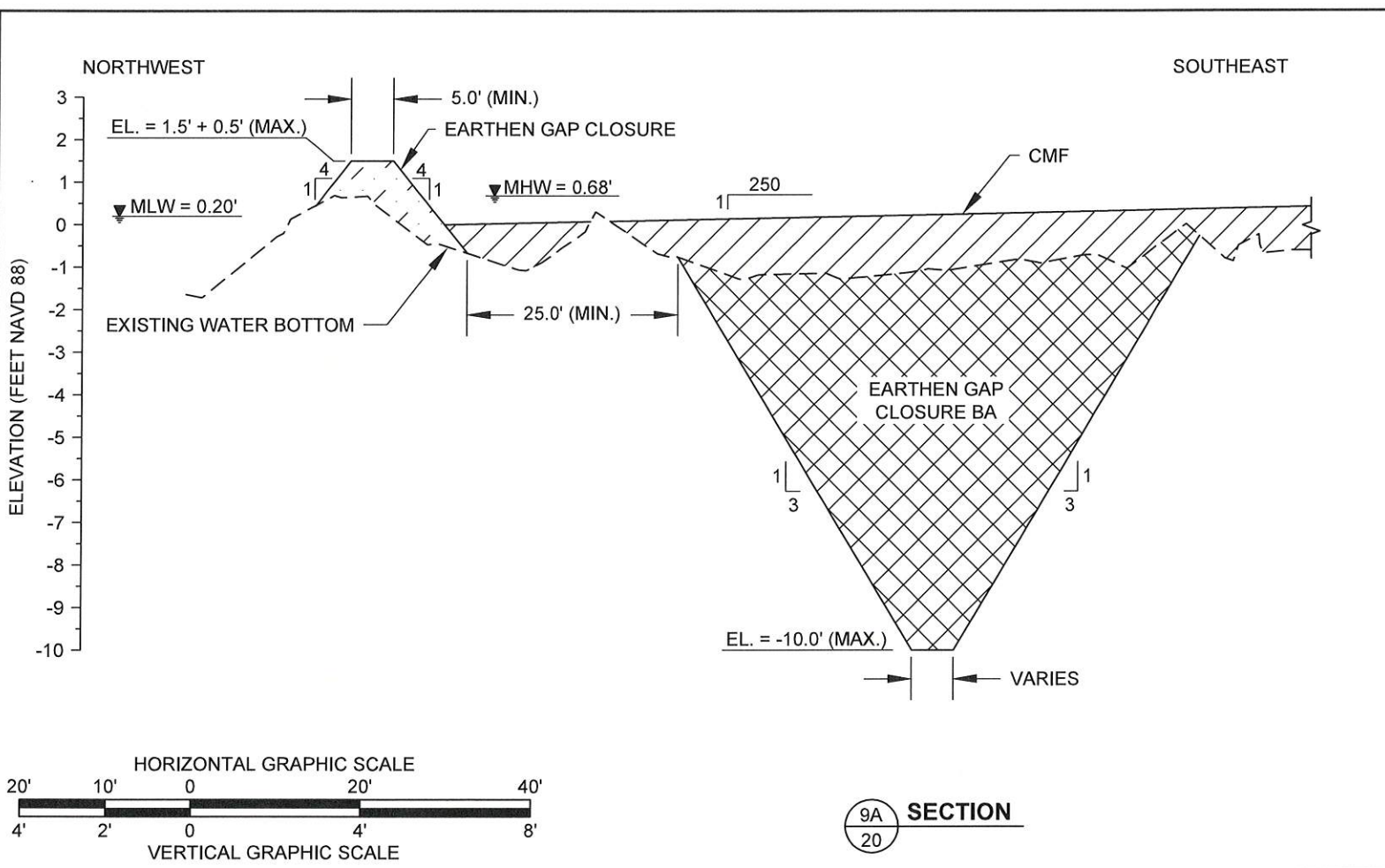

9A SECTION
20

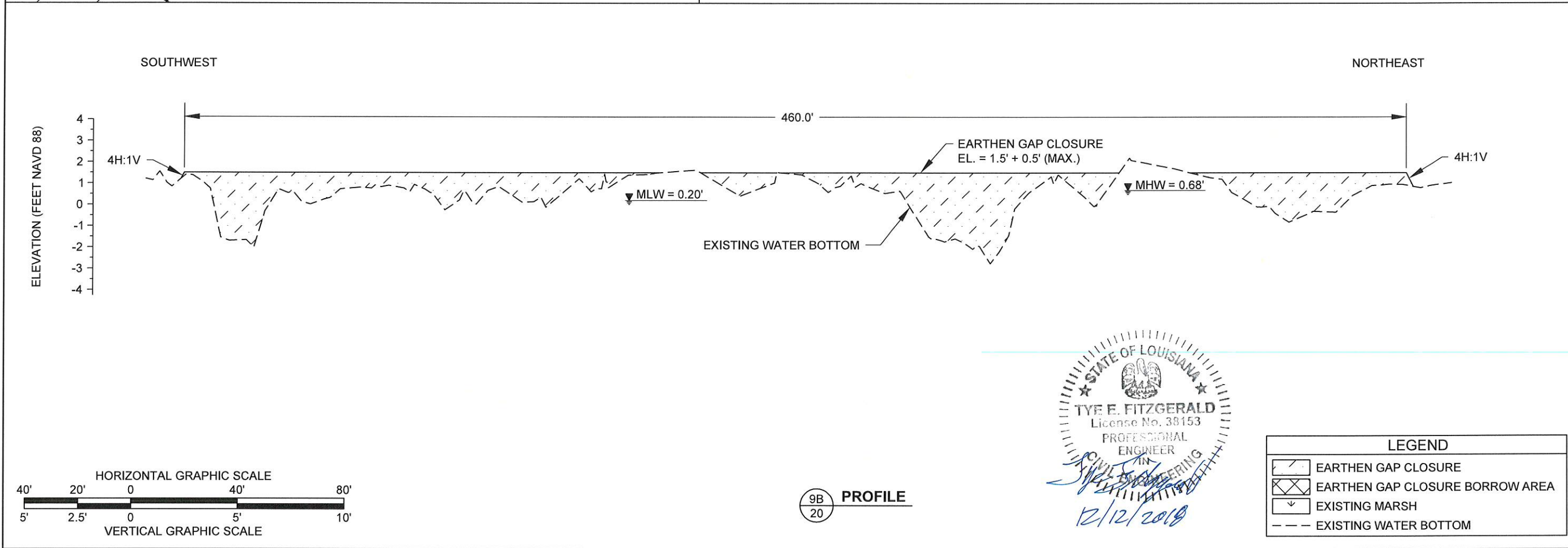

9B PROFILE
20

STATE OF LOUISIANA
 TYE E. FITZGERALD
 License No. 38153
 PROFESSIONAL ENGINEER
 CIVIL ENGINEERING
 12/12/2018

LEGEND	
	EARTHEN GAP CLOSURE
	EARTHEN GAP CLOSURE BORROW AREA
	EXISTING MARSH
	EXISTING WATER BOTTOM

REV.	DATE	DESCRIPTION	BY

COASTAL PROTECTION AND RESTORATION AUTHORITY
 150 TERRACE AVENUE
 BATON ROUGE, LOUISIANA 70802

EARTHEN GAP CLOSURE 9 PLAN, SECTION, AND PROFILE VIEWS	DESIGNED BY: T. MCLAIN, P.E.
	APPROVED BY: T. FITZGERALD, P.E.

NORTHWEST TURTLE BAY MARSH CREATION PROJECT	STATE PROJECT NUMBER: BA-0125
	DRAWN BY: K. CANTU

DATE: DEC. 2018
 SHEET 20 OF 79

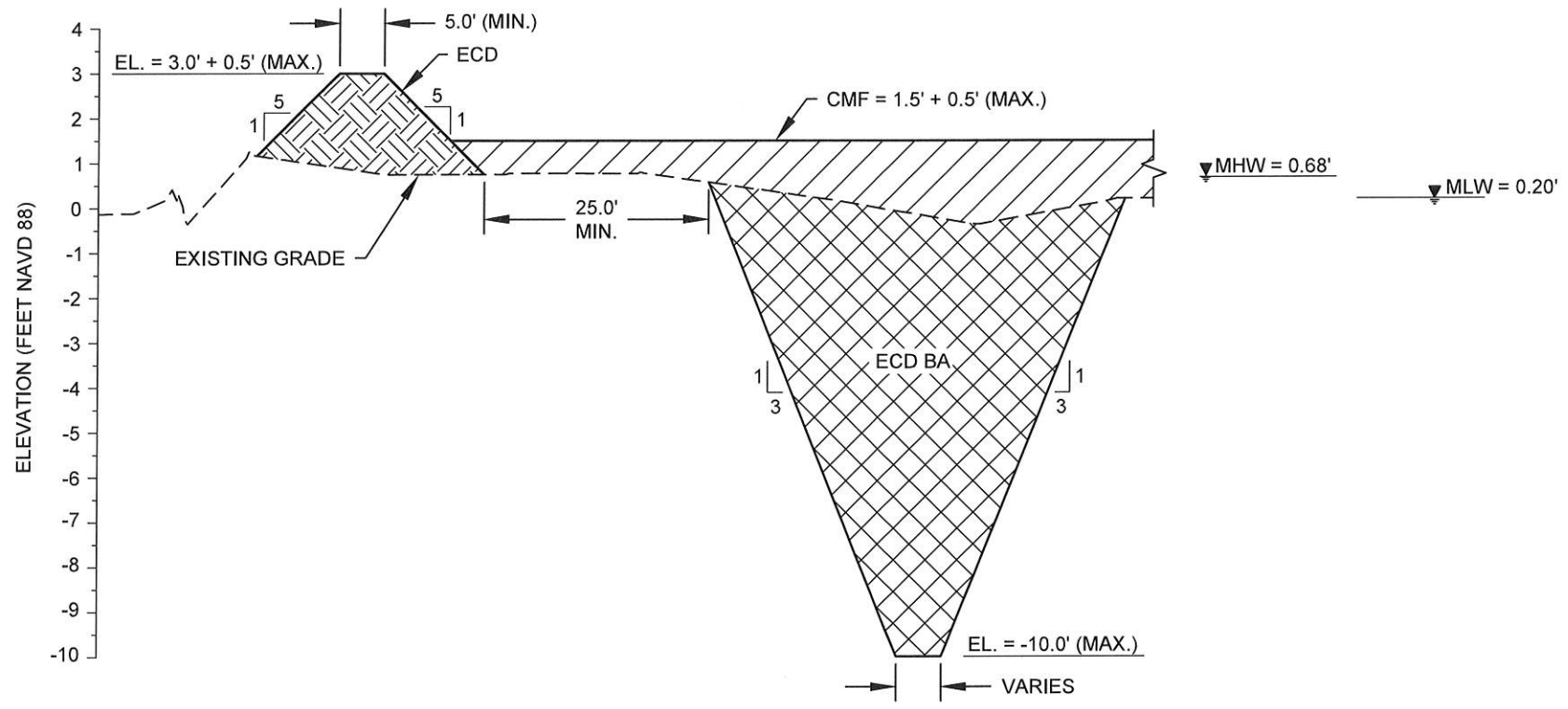

**E-ECD EAST EARTHEN CONTAINMENT DIKE
7 DETAIL**

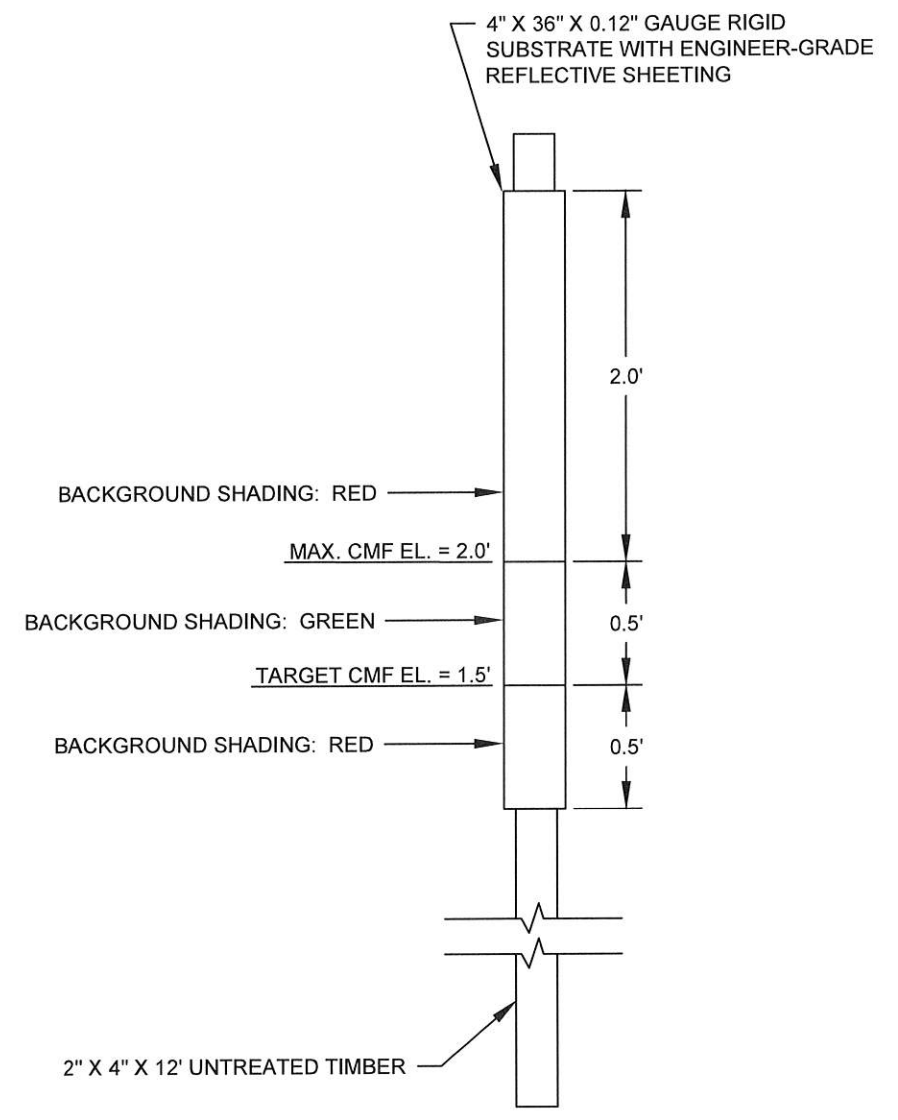
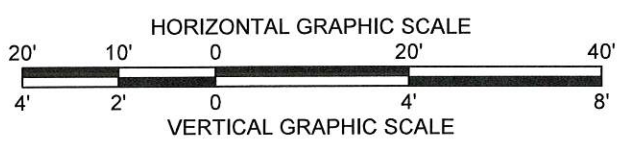

**GRADE STAKE
NTS**

STATE OF LOUISIANA
 TYE E. FITZGERALD
 License No. 38153
 PROFESSIONAL
 ENGINEER
 IN
 CIVIL ENGINEERING
Tye Fitzgerald
 12/12/2018

LEGEND	
	EARTHEN CONTAINMENT DIKE
	ECD BORROW AREA
	MARSH CREATION FILL
	EXISTING GRADE

NORTHWEST TURTLE BAY MARSH CREATION PROJECT		COASTAL PROTECTION AND RESTORATION AUTHORITY 150 TERRACE AVENUE BATON ROUGE, LOUISIANA 70802	
STATE PROJECT NUMBER: BA-0125	DESIGNED BY: T. MCLAIN, E.I.	DATE	DESCRIPTION
DRAWN BY: K. CANTU	APPROVED BY: T. FITZGERALD, P.E.	REV.	BY
DATE: DEC. 2018		P.E. NO. 38153	
SHEET 22 OF 79			

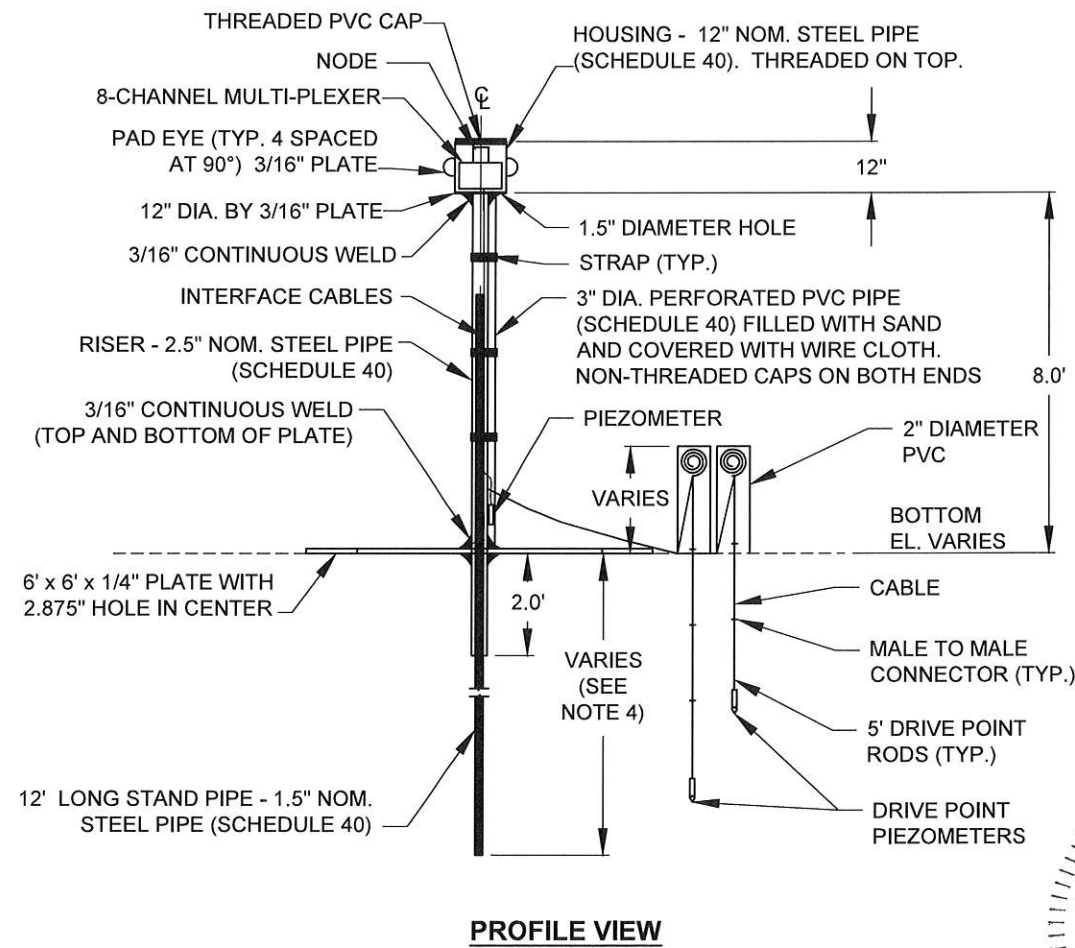
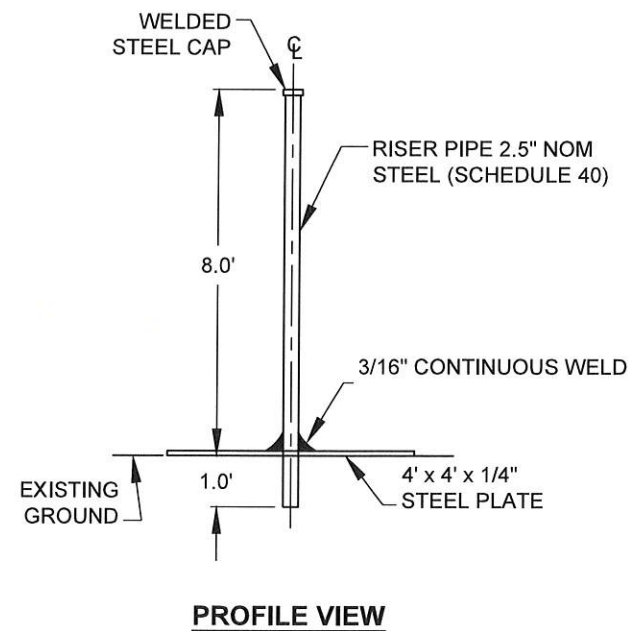
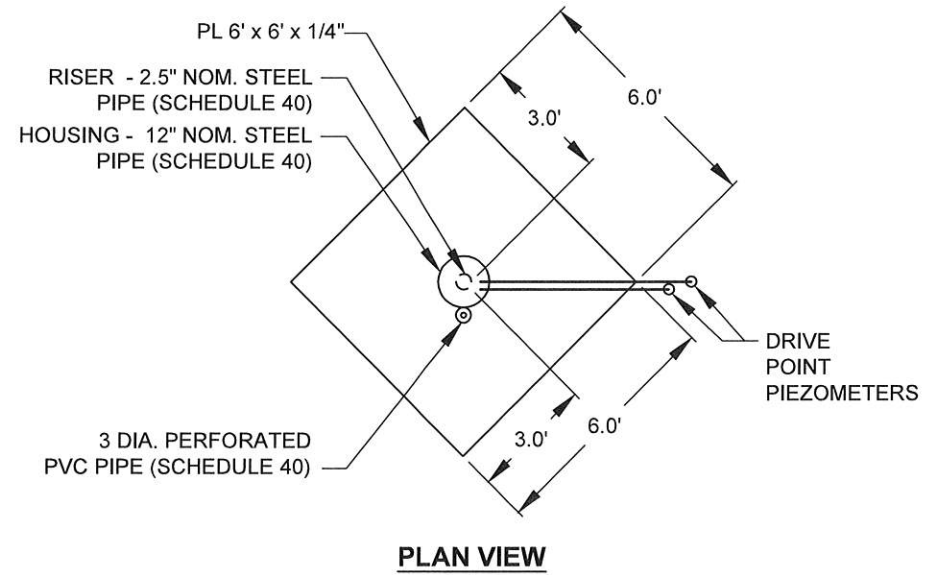
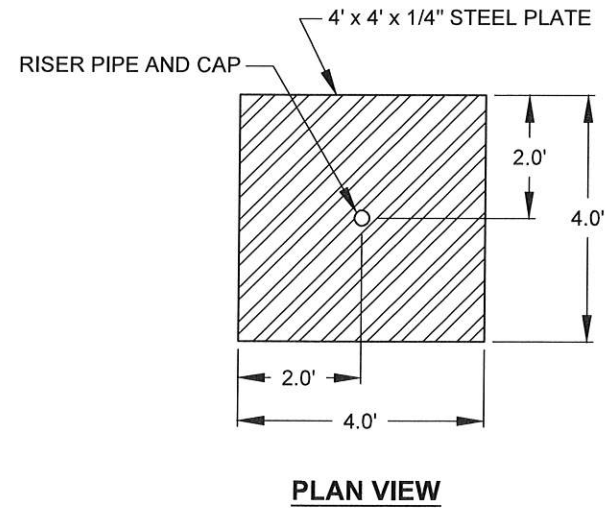

MARSH CREATION AREA SETTLEMENT PLATE
NTS

INSTRUMENTED SETTLEMENT PLATE
NTS

- NOTES:**
1. SETTLEMENT PLATES SHALL BE INSTALLED AT THE LOCATIONS SHOWN ON THE PLANS.
 2. CONTRACTOR TO DRIVE STAND PIPE BELOW GRADE TO THE DEPTH DETERMINED BY THE ENGINEER IN THE FIELD.



COASTAL PROTECTION AND RESTORATION AUTHORITY
150 TERRACE AVENUE
BATON ROUGE, LOUISIANA 70802

SETTLEMENT PLATE DETAILS	DESIGNED BY: T. MCLAIN, E.I.	APPROVED BY: T. FITZGERALD, P.E. P.E. NO. 38153
NORTHWEST TURTLE BAY MARSH CREATION PROJECT	STATE PROJECT NUMBER: BA-0125	DRAWN BY: K. CANTU

REV.	DATE	DESCRIPTION	BY

SOIL BORING COORDINATES		
	NORTHING	EASTING
BHBA-1	382,612.38	3,662,082.33
BHBA-2	381,348.56	3,661,817.29
BHBA-3	380,114.04	3,662,438.21
BHBA-4	379,112.32	3,661,824.37
BHBA-5	379,111.47	3,663,086.38
BHBA-6	379,113.64	3,664,534.01

STATE OF LOUISIANA
 TYE E. FITZGERALD
 License No. 38153
 PROFESSIONAL ENGINEER
 12/12/2018

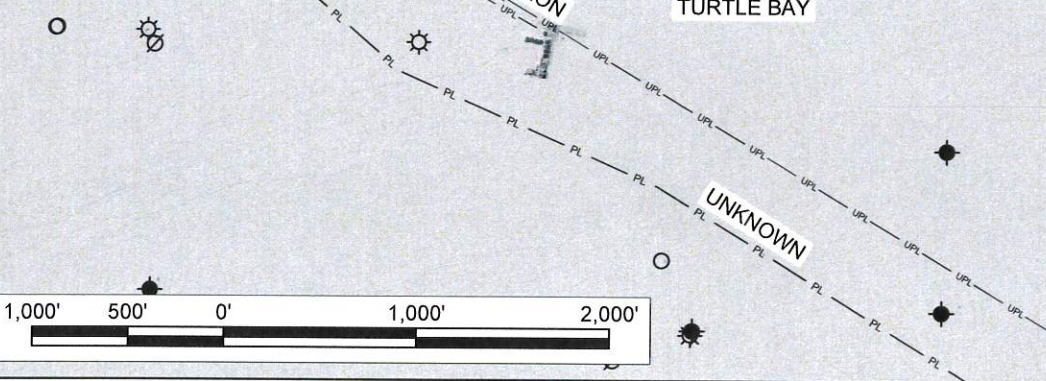
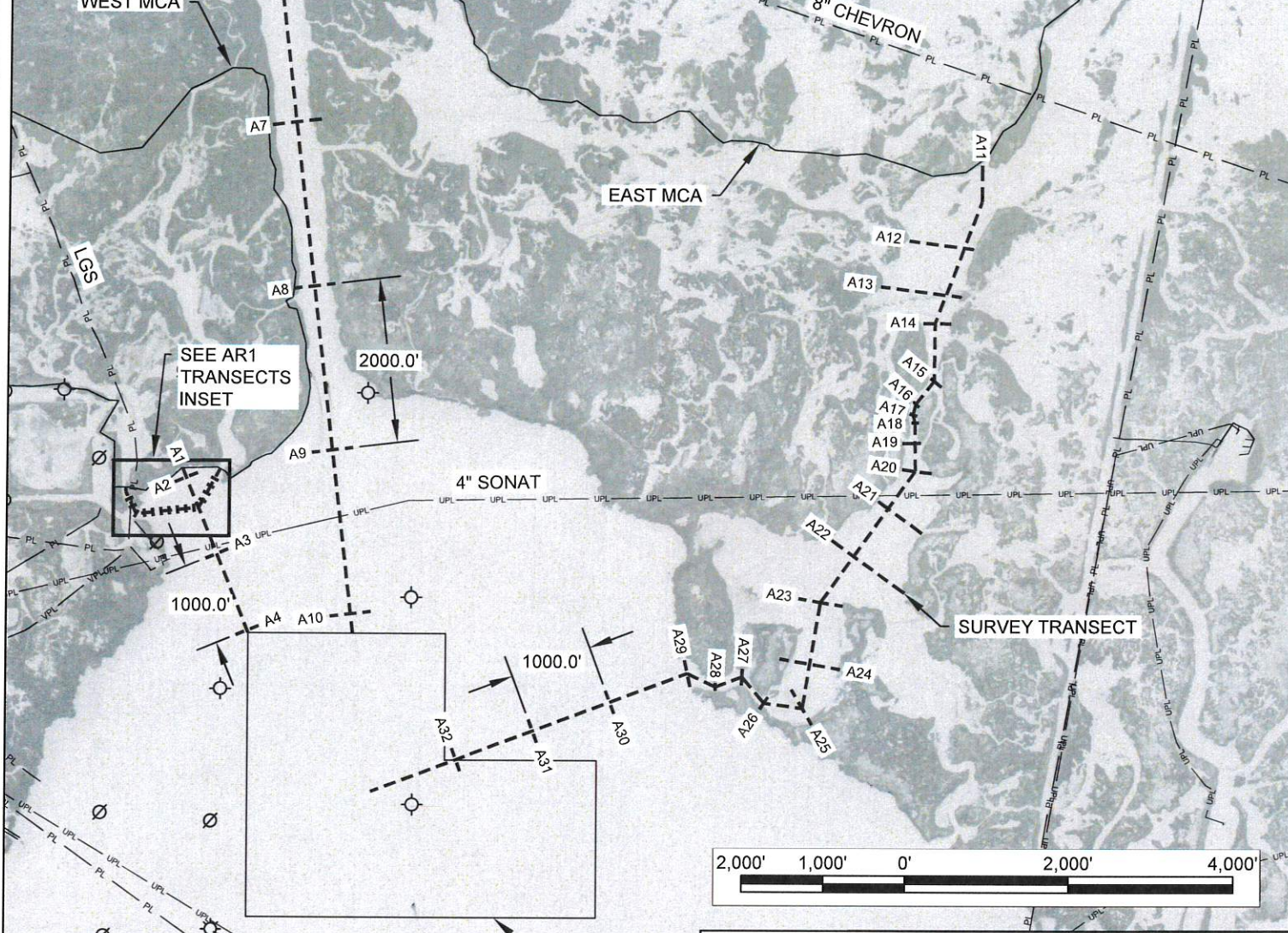
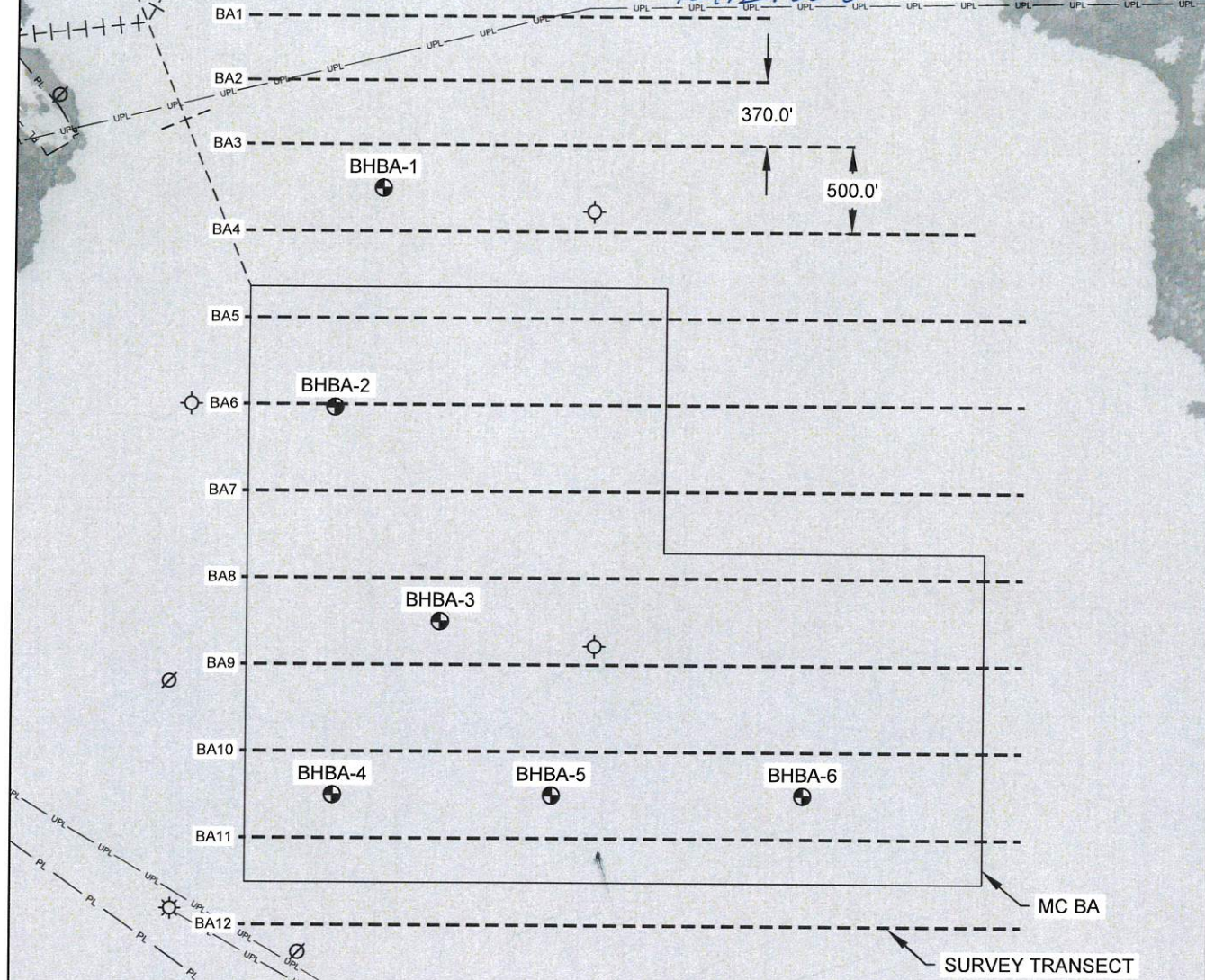

LEGEND	
---	SURVEY TRANSECT
— PL —	VERIFIED PIPELINE
— UPL —	UNVERIFIED PIPELINE
●	SOIL BORING
△	SURVEY MONUMENT
☼	ACTIVE WELL
⊙	DRY AND PLUGGED WELL
⊘	PERMIT EXPIRED - WELL
⊗	PLUGGED AND ABANDONED WELL
●	SHUT-IN PRODUCTIVE WELL

COASTAL PROTECTION AND RESTORATION AUTHORITY 150 TERRACE AVENUE BATON ROUGE, LOUISIANA 70802	
MARSH CREATION BORROW AREA AND ACCESS ROUTE DESIGN SURVEY LAYOUT	DESIGNED BY: T. MCCLAIN, E.I. APPROVED BY: T. FITZGERALD, P.E. P.E. NO. 38153
NORTHWEST TURTLE BAY MARSH CREATION PROJECT	STATE PROJECT NUMBER: BA-0125 DRAWN BY: K. CANTU
DATE: DEC 2018	
SHEET 24 OF 79	

SOIL BORING COORDINATES		
	NORTHING	EASTING
BHMC-1	387,815.56	3,660,632.12
BHMC-2	386,848.63	3,658,375.85
BHMC-3	386,278.71	3,659,710.74
BHMC-4	386,031.89	3,656,366.59
BHMC-5	384,534.37	3,661,022.21
BHMC-6	384,065.99	3,658,723.47
BHMC-7	382,795.44	3,656,400.11
BHMC-8	382,732.84	3,657,945.39
BHMC-9	381,813.36	3,657,132.14



REV.	DATE	DESCRIPTION	BY

COASTAL PROTECTION AND RESTORATION AUTHORITY
 150 TERRACE AVENUE
 BATON ROUGE, LOUISIANA 70802

WEST MARSH CREATION
 AREA DESIGN SURVEY LAYOUT
 DESIGNED BY: T. MCCLAIN, E.I.
 APPROVED BY: T. FITZGERALD, P.E. P.E. NO. 38153

NORTHWEST TURTLE BAY
 MARSH CREATION PROJECT
 STATE PROJECT NUMBER: BA-0125
 DRAWN BY: K. CANTU
 DATE: DEC. 2018
 SHEET 25 OF 79

LEGEND	
---	SURVEY TRANSECT
— PL —	VERIFIED PIPELINE
— UPL —	UNVERIFIED PIPELINE
⊕	SOIL BORING
⊙	ACTIVE WELL
⊘	DRY AND PLUGGED WELL
⊖	PERMIT EXPIRED - WELL
⊗	PLUGGED AND ABANDONED WELL
⬤	SHUT-IN PRODUCTIVE WELL

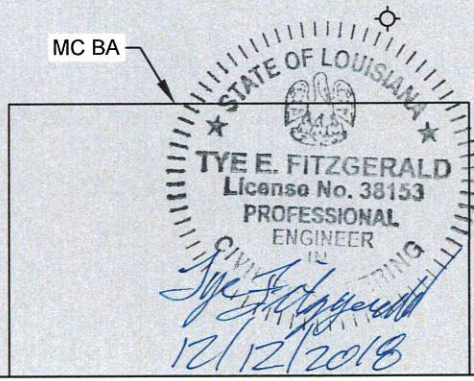

SOIL BORING COORDINATES

	NORTHING	EASTING
B-1	389,698.40	3,665,345.32
B-2	389,263.15	3,666,886.58
B-3	387,798.22	3,667,919.53
B-4	388,752.17	3,668,330.65
B-5	388,697.31	3,669,628.59
B-6	389,827.70	3,670,005.99

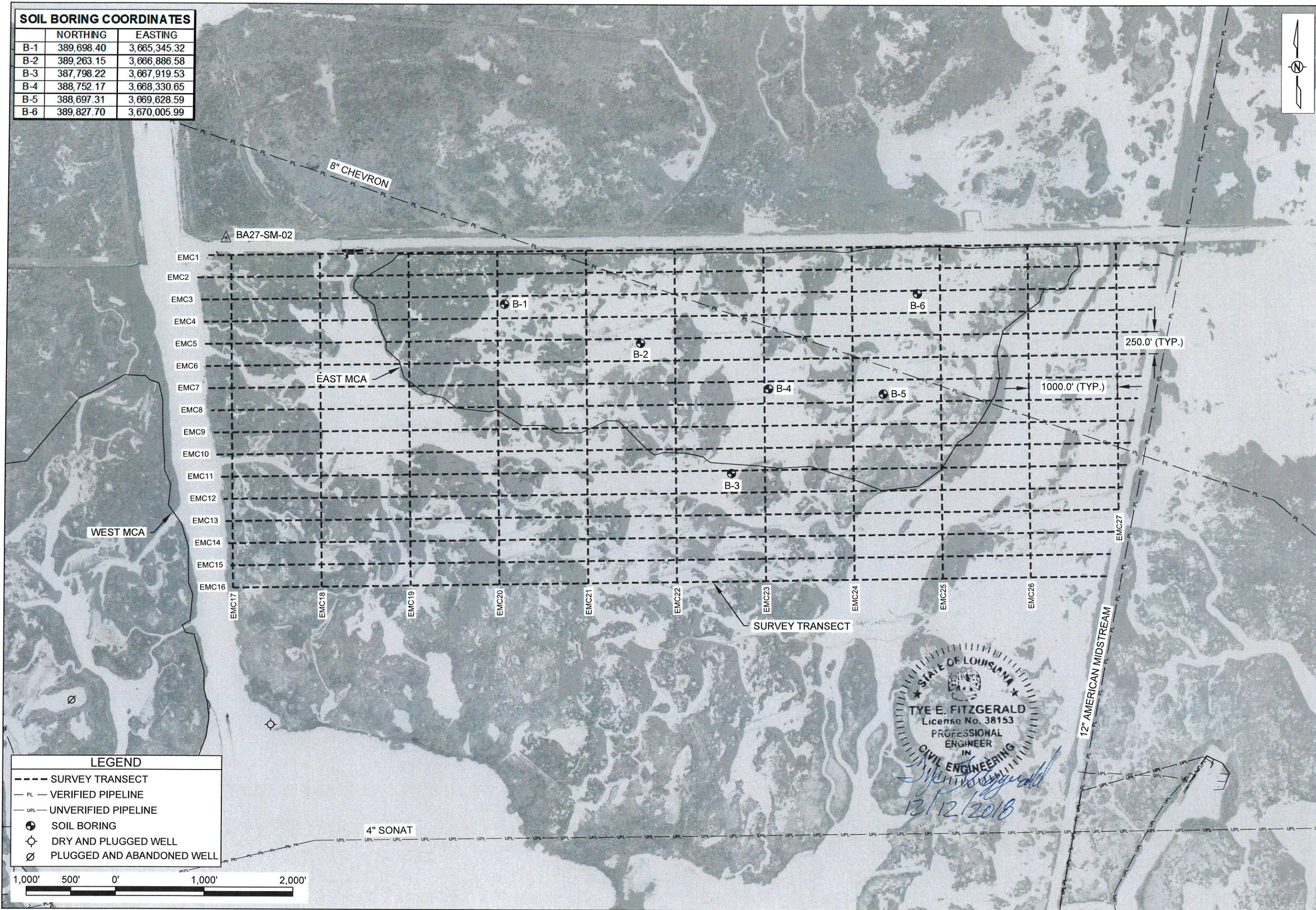

LEGEND

- SURVEY TRANSECT
- PL - VERIFIED PIPELINE
- UPL - UNVERIFIED PIPELINE
- SOIL BORING
- DRY AND PLUGGED WELL
- ⊘ PLUGGED AND ABANDONED WELL

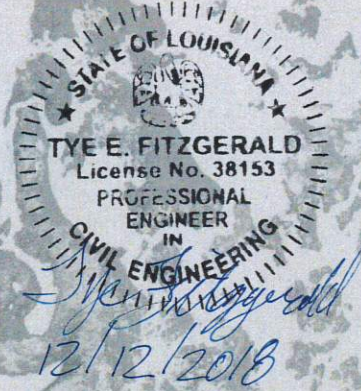

REV.	DATE	DESCRIPTION	BY

COASTAL PROTECTION AND RESTORATION AUTHORITY
 150 TERRACE AVENUE
 BATON ROUGE, LOUISIANA 70802

EAST MARSH CREATION
 AREA DESIGN SURVEY LAYOUT

DESIGNED BY: T. MCCLAIN, E.I.
 APPROVED BY: T. FITZGERALD, P.E. P.E. NO. 38153

NORTHWEST TURTLE BAY
 MARSH CREATION PROJECT

STATE PROJECT NUMBER: BA-0125
 DRAWN BY: K. CANTU

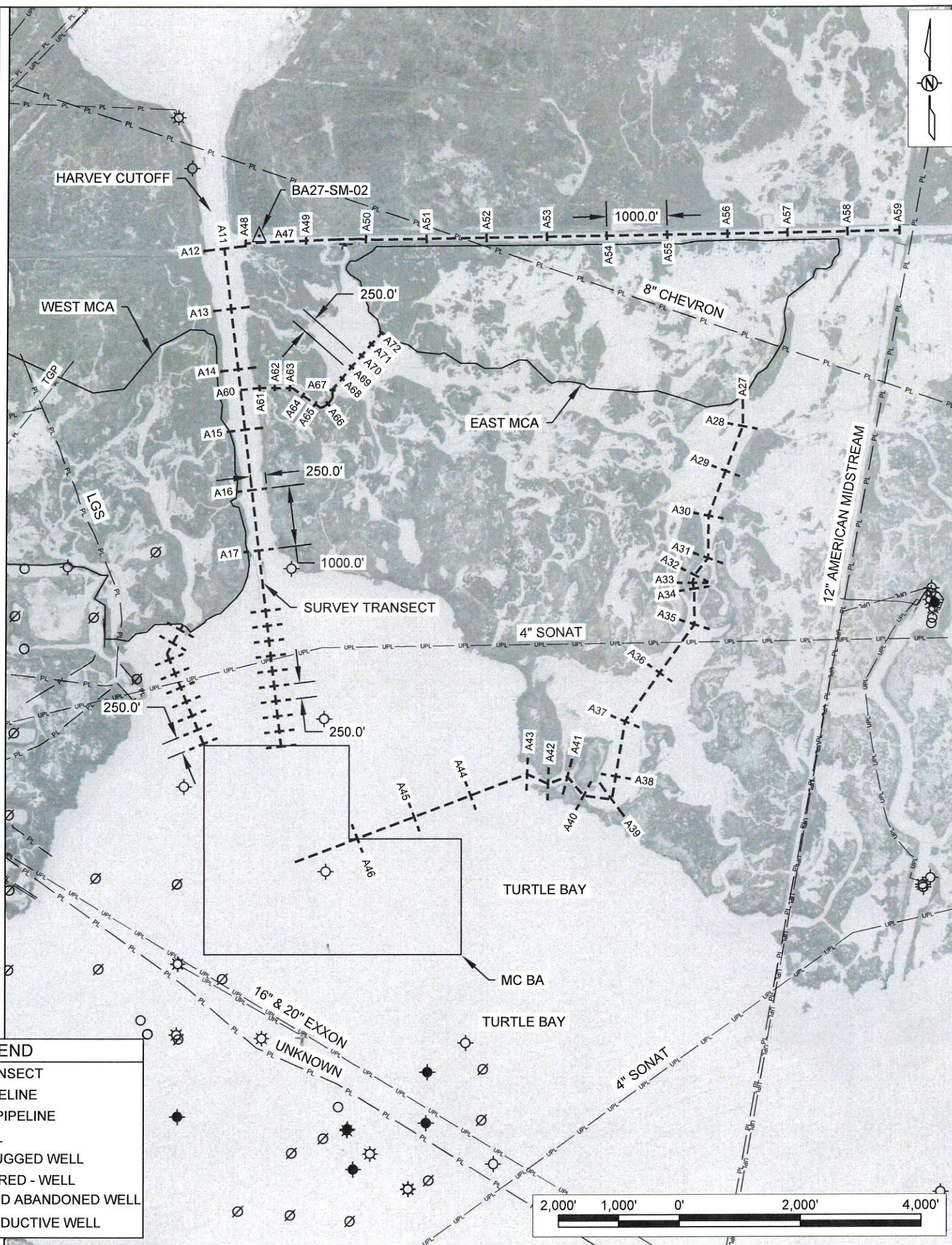
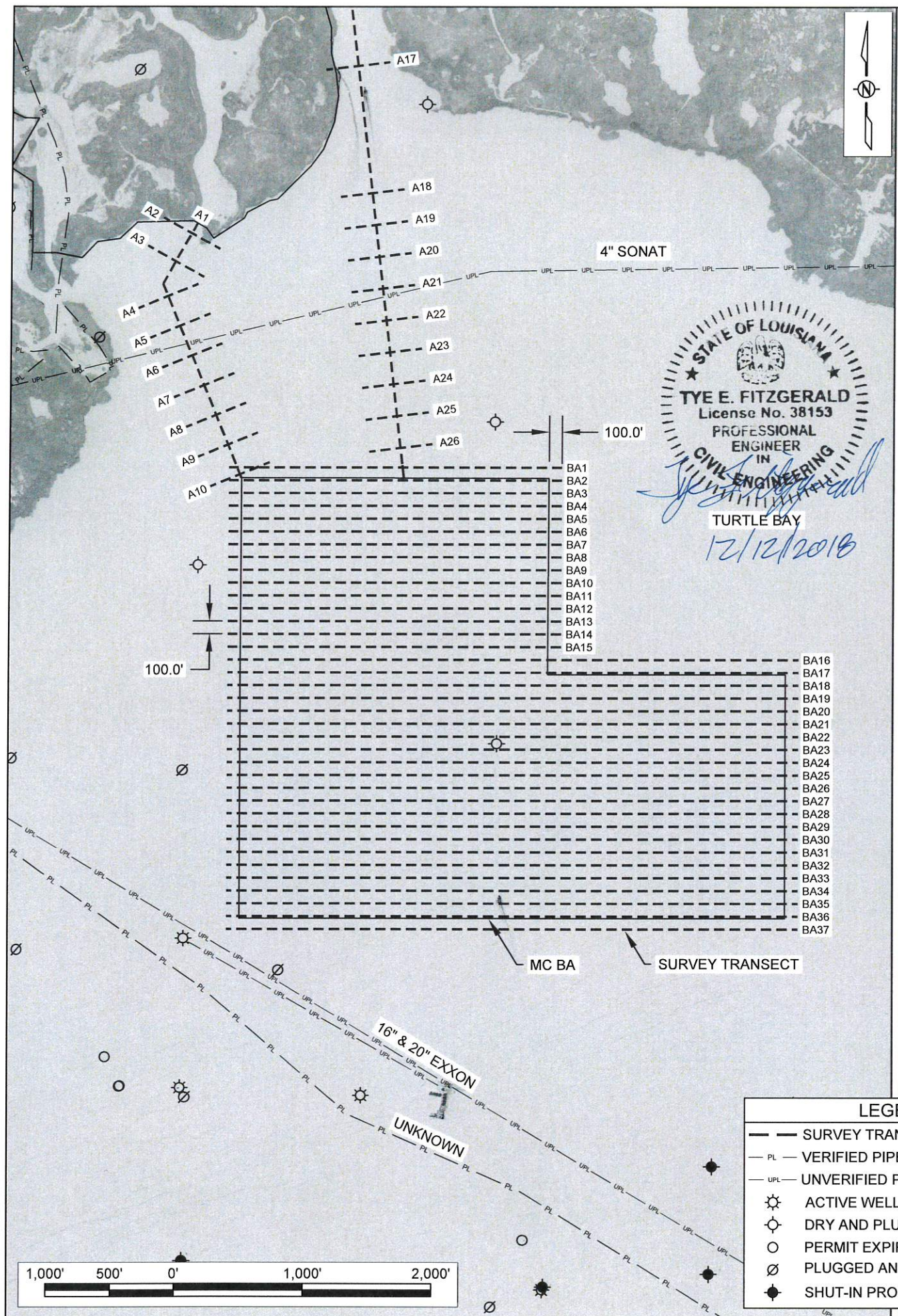

LEGEND	
	SURVEY TRANSECT
	VERIFIED PIPELINE
	UNVERIFIED PIPELINE
	ACTIVE WELL
	DRY AND PLUGGED WELL
	PERMIT EXPIRED - WELL
	PLUGGED AND ABANDONED WELL
	SHUT-IN PRODUCTIVE WELL

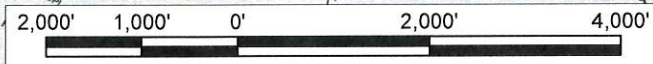

REV.	DATE	DESCRIPTION	BY

COASTAL PROTECTION AND RESTORATION AUTHORITY
 150 TERRACE AVENUE
 BATON ROUGE, LOUISIANA 70802

MARSH CREATION BORROW AREA AND ACCESS ROUTE CONSTRUCTION SURVEY LAYOUT

DESIGNED BY: T. MCLAIN, E.I.
 APPROVED BY: T. FITZGERALD, P.E. P.E. NO. 38153

NORTHWEST TURTLE BAY MARSH CREATION PROJECT

STATE PROJECT NUMBER: BA-0125
 DRAWN BY: K. CANTU

DATE: DEC. 2018
 SHEET 29 OF 79

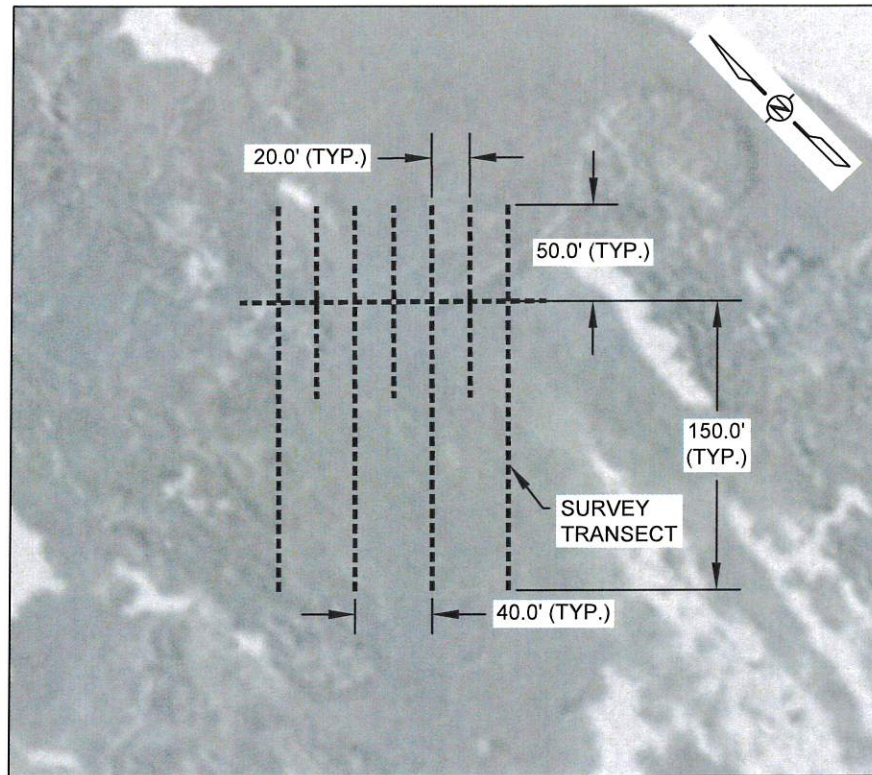

EARTHEN GAP CLOSURE 1

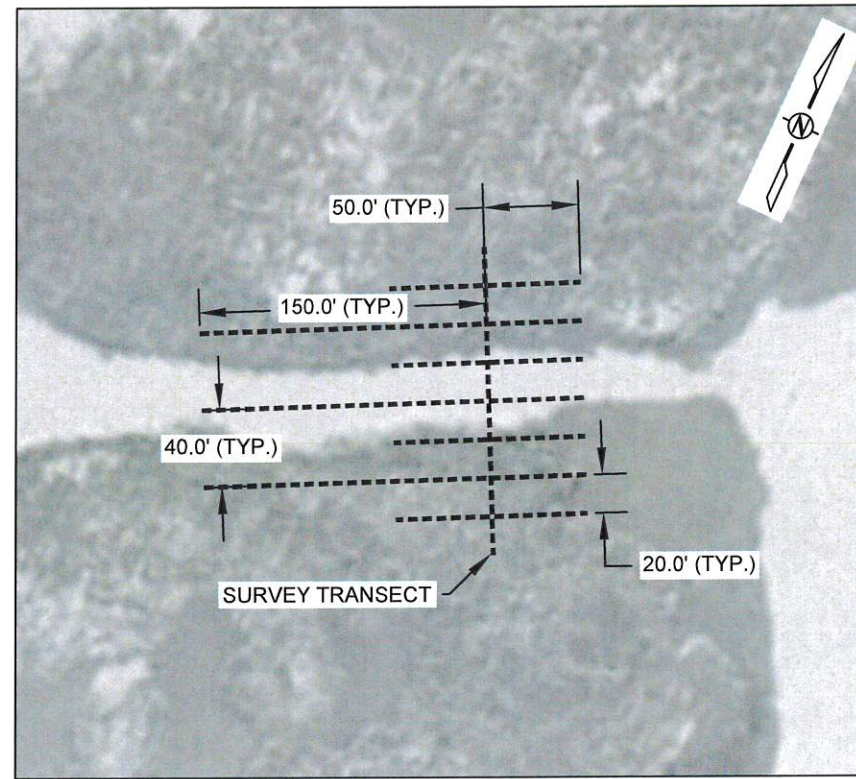

EARTHEN GAP CLOSURE 4

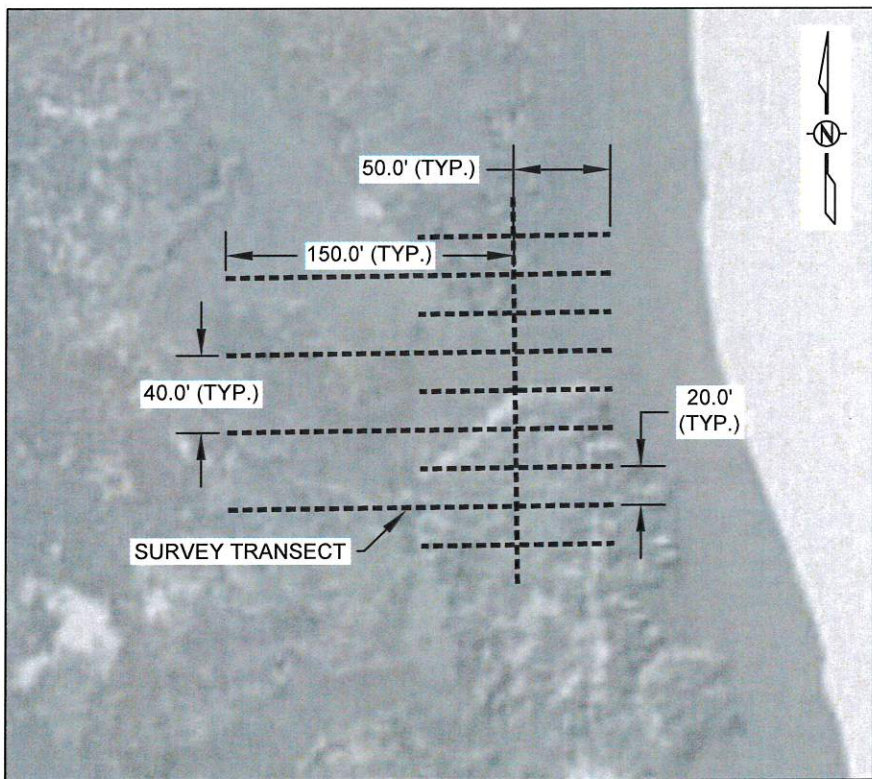

EARTHEN GAP CLOSURE 2

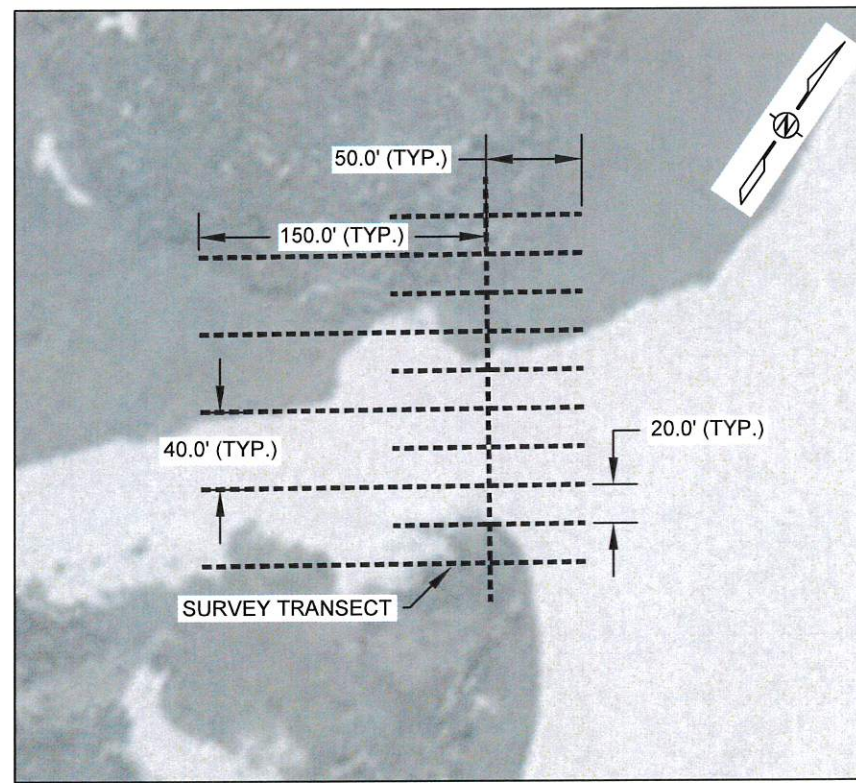

EARTHEN GAP CLOSURE 3



STATE OF LOUISIANA
 TYE E. FITZGERALD
 License No. 38153
 PROFESSIONAL ENGINEER
 CIVIL ENGINEERING
Tye E. Fitzgerald
 12/12/2018

LEGEND

----- BATHYMETRIC & TOPOGRAPHIC SURVEY TRANSECT

COASTAL PROTECTION AND RESTORATION AUTHORITY 150 TERRACE AVENUE BATON ROUGE, LOUISIANA 70802		REV.	DATE	DESCRIPTION	BY
WEST MARSH CREATION AREA CONSTRUCTION SURVEY LAYOUT		DESIGNED BY: T. MCLAIN, E.I.	APPROVED BY: T. FITZGERALD, P.E.	P. E. NO. 38153	
NORTHWEST TURTLE BAY MARSH CREATION PROJECT	STATE PROJECT NUMBER: BA-0125	DRAWN BY: K. CANTU	DATE: DEC 2018	SHEET 31 OF 79	

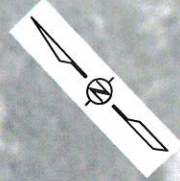
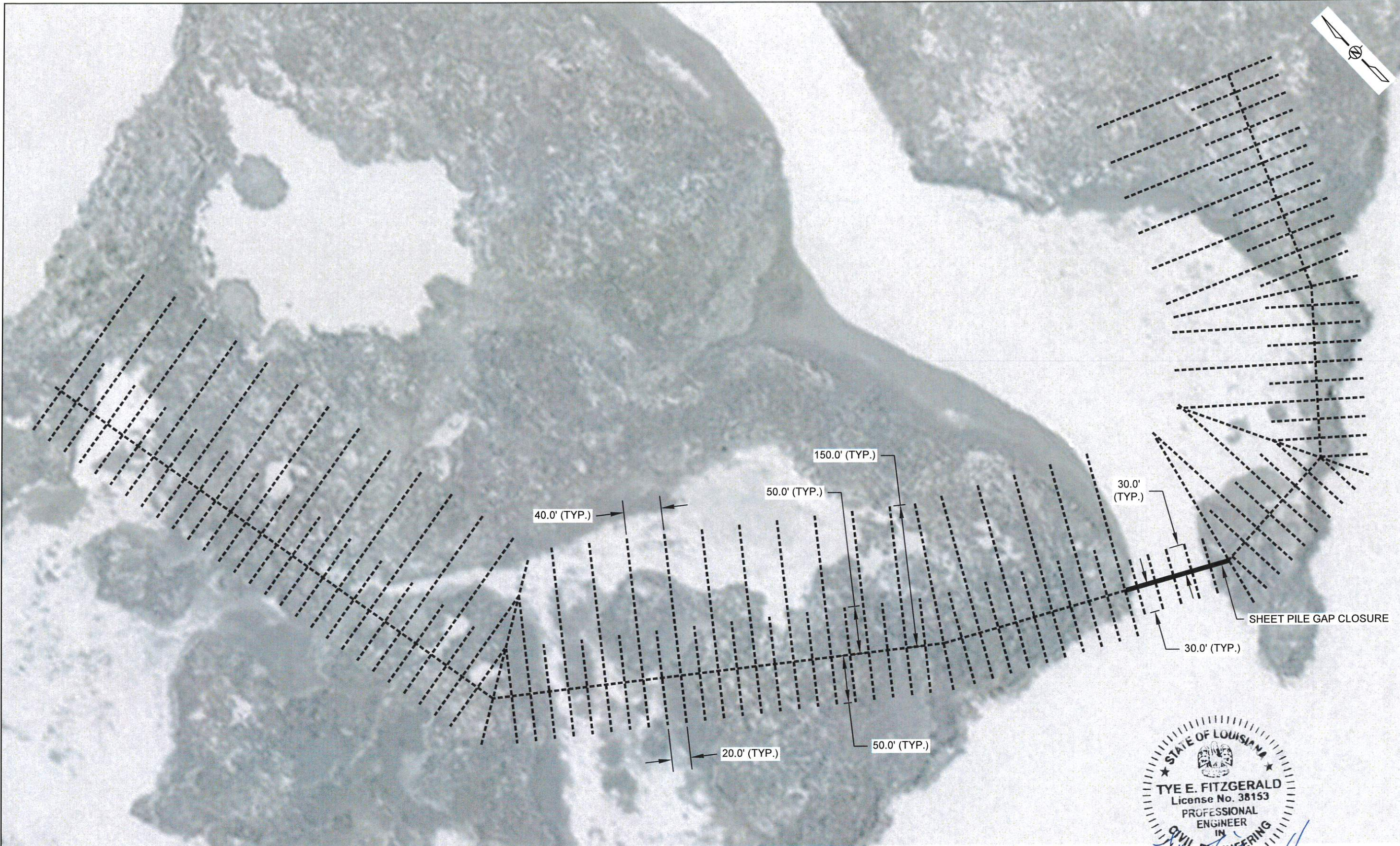

EARTHEN GAP CLOSURES 5 - 6 AND SHEET PILE CLOSURE

TYE E. FITZGERALD
 License No. 38153
 PROFESSIONAL ENGINEER
 IN
 CIVIL ENGINEERING
Tye E. Fitzgerald
 12/12/2018

LEGEND	
-----	BATHYMETRIC & TOPOGRAPHIC SURVEY TRANSECT

REV.	DATE	DESCRIPTION	BY

COASTAL PROTECTION AND RESTORATION AUTHORITY
 150 TERRACE AVENUE
 BATON ROUGE, LOUISIANA 70802

WEST MARSH CREATION AREA
 CONSTRUCTION SURVEY LAYOUT
 DESIGNED BY: T. MCLAIN, E.I.
 APPROVED BY: T. FITZGERALD, P.E. P.E. NO. 38153

NORTHWEST TURTLE BAY
 MARSH CREATION PROJECT
 STATE PROJECT NUMBER: BA-0125
 DRAWN BY: K. CANTU

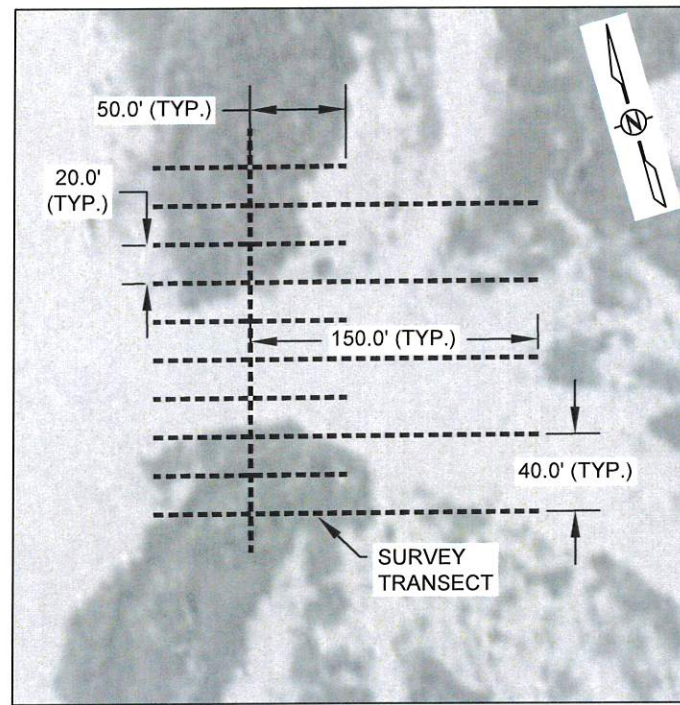

EARTHEN GAP CLOSURE 7

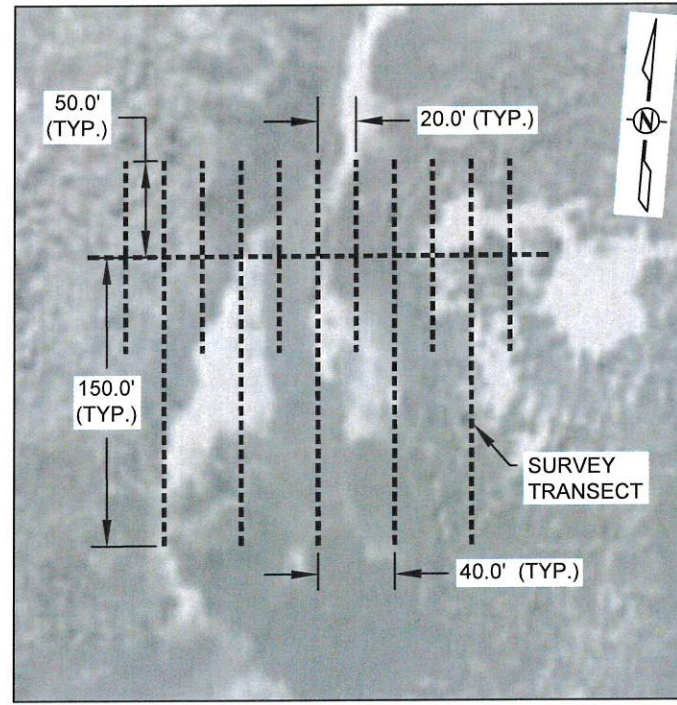

EARTHEN GAP CLOSURE 8

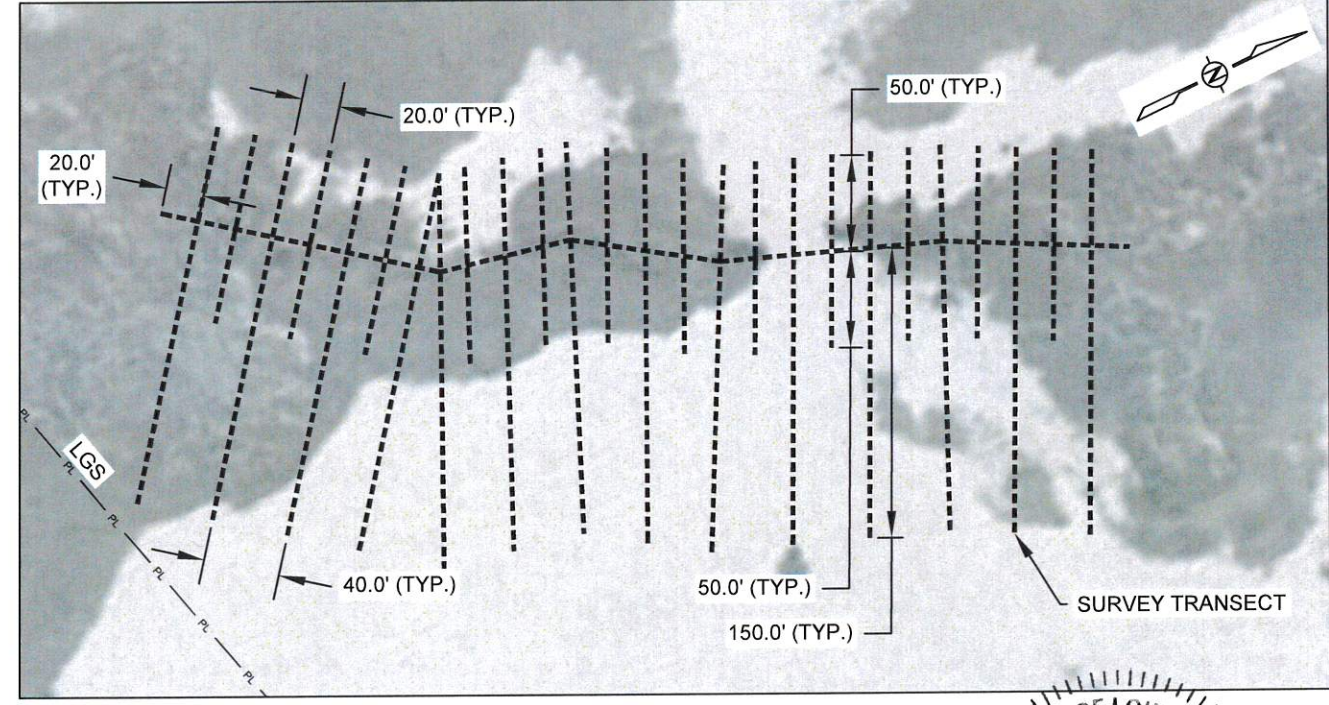

EARTHEN GAP CLOSURE 9



STATE OF LOUISIANA
 TYE E. FITZGERALD
 License No. 38153
 PROFESSIONAL ENGINEER
 IN
 CIVIL ENGINEERING
T. FitzGerald
 12/12/2018

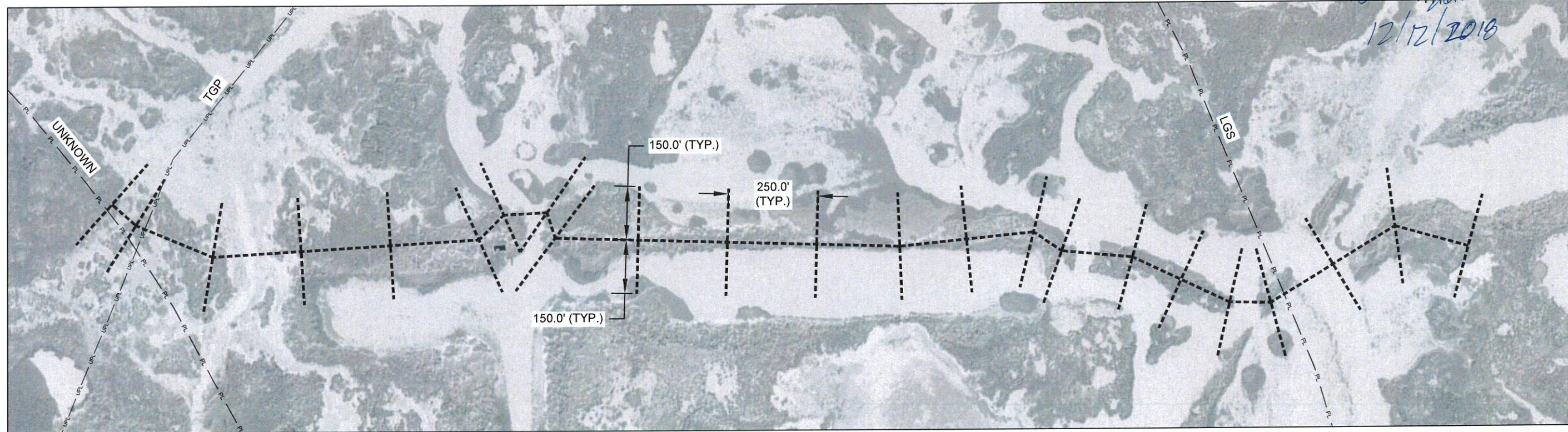

SOUTHERN EARTHEN CONTAINMENT DIKE



LEGEND	
---	BATHYMETRIC & TOPOGRAPHIC SURVEY TRANSECT
— PL —	VERIFIED PIPELINE
— UPL —	UNVERIFIED PIPELINE

COASTAL PROTECTION AND RESTORATION AUTHORITY 150 TERRACE AVENUE BATON ROUGE, LOUISIANA 70802	
WEST MARSH CREATION AREA CONSTRUCTION SURVEY LAYOUT	DESIGNED BY: T. MCLAIN, E.I. APPROVED BY: T. FITZGERALD, P.E. P.E. NO. 38153
NORTHWEST TURTLE BAY MARSH CREATION PROJECT	STATE PROJECT NUMBER: BA-0125 DRAWN BY: K. CANTU
DATE: DEC. 2018	SHEET 33 OF 79
REV.	DATE
DESCRIPTION	BY

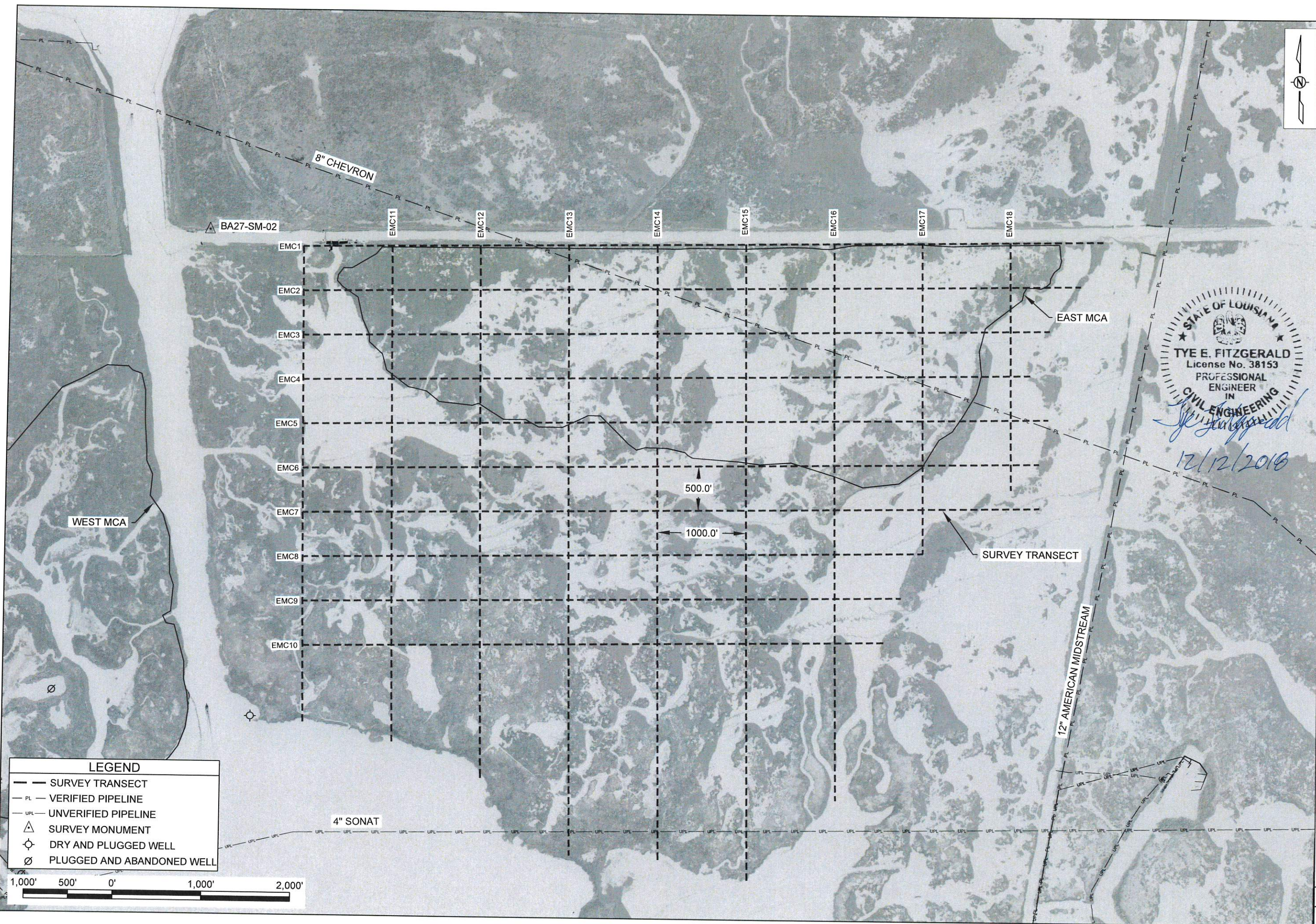

STATE OF LOUISIANA
 TYE E. FITZGERALD
 License No. 38153
 PROFESSIONAL ENGINEER IN CIVIL ENGINEERING
T. E. Fitzgerald
 12/12/2018

LEGEND	
	SURVEY TRANSECT
	VERIFIED PIPELINE
	UNVERIFIED PIPELINE
	SURVEY MONUMENT
	DRY AND PLUGGED WELL
	PLUGGED AND ABANDONED WELL



REV.	DATE	DESCRIPTION	BY

COASTAL PROTECTION AND RESTORATION AUTHORITY
 150 TERRACE AVENUE
 BATON ROUGE, LOUISIANA 70802

EAST MARSH CREATION AREA CONSTRUCTION SURVEY LAYOUT
 DESIGNED BY: T. MCCLAIN, E.I.
 APPROVED BY: T. FITZGERALD, P.E. P.E. NO. 38153

NORTHWEST TURTLE BAY MARSH CREATION PROJECT
 STATE PROJECT NUMBER: BA-0125
 DRAWN BY: K. CANTU

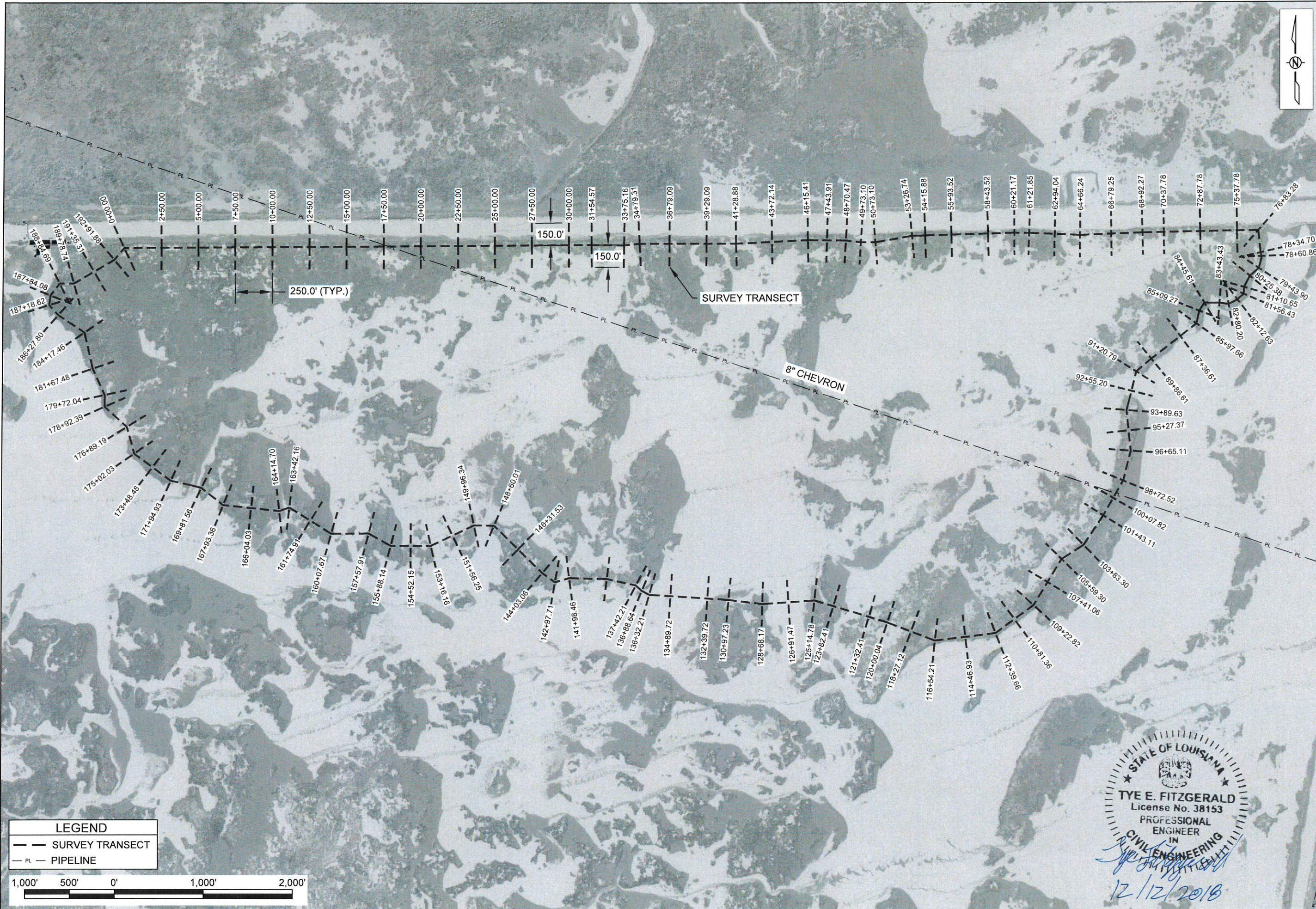

LEGEND	
	SURVEY TRANSECT
	PIPELINE

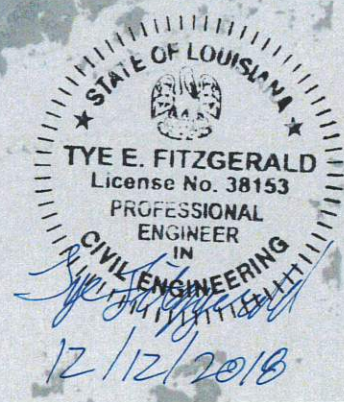

NORTHWEST TURTLE BAY MARSH CREATION PROJECT		EAST MARSH CREATION AREA CONSTRUCTION SURVEY LAYOUT		COASTAL PROTECTION AND RESTORATION AUTHORITY 150 TERRACE AVENUE BATON ROUGE, LOUISIANA 70802	
DATE:	DEC. 2018	DESIGNED BY:	T. MCLAIN, E.I.	REV.	DATE
SHEET	35 OF 79	APPROVED BY:	T. FITZGERALD, P.E.	DESCRIPTION	BY
		DRAWN BY:	K. CANTU		
		STATE PROJECT NUMBER:	BA-0125		
		P.E. NO.	38153		

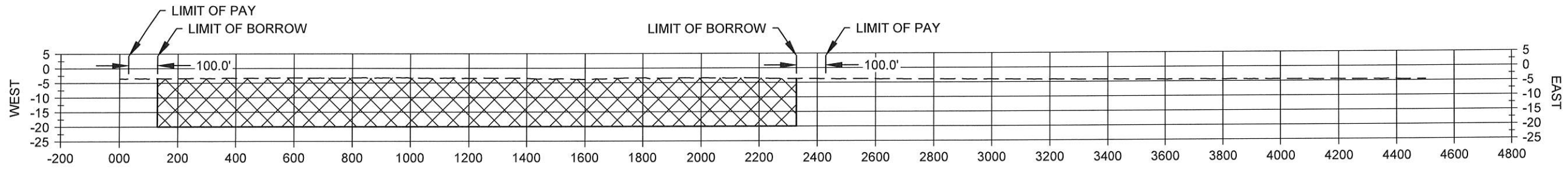

BA7

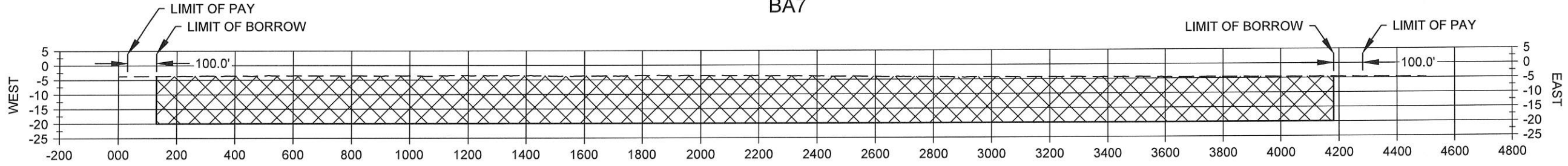

BA8

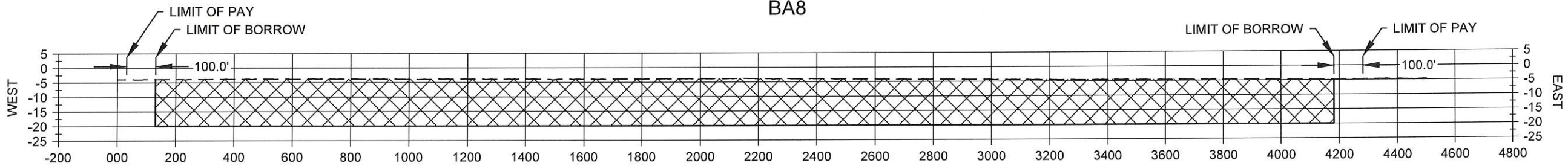

BA9

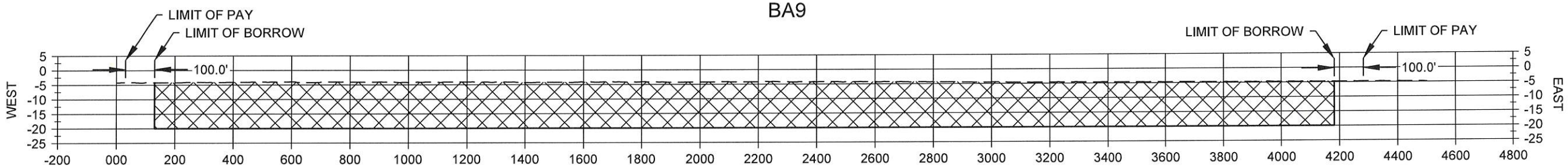

BA-10

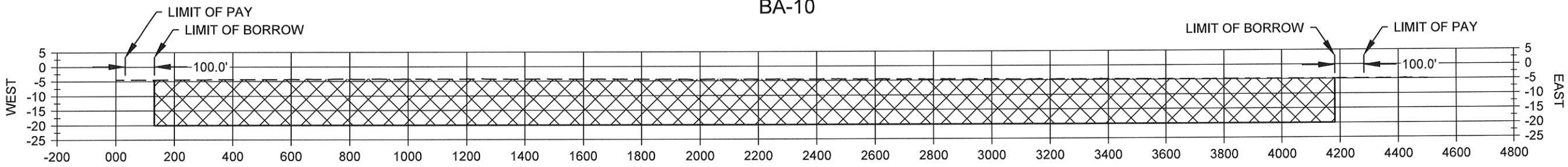

BA-11

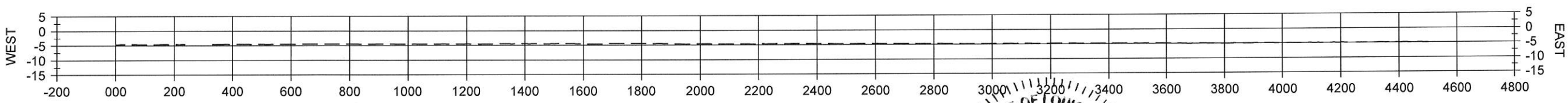

BA12

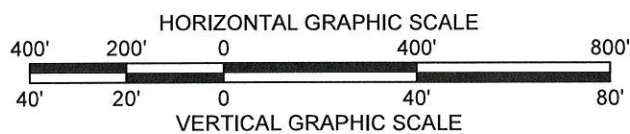

LEGEND	
	WATER BOTTOM
	MARSH CREATION BORROW AREA

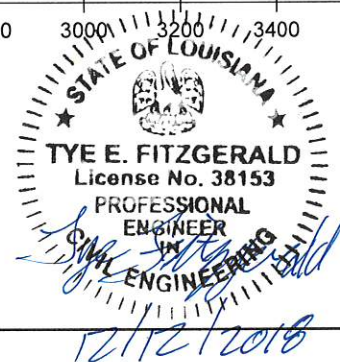

NOTE:
ALL ELEVATIONS ARE GIVEN IN THE NORTH AMERICAN
VERTICAL DATUM OF 1988 (NAVD88) GEOID 12A.

COASTAL PROTECTION AND RESTORATION AUTHORITY 150 TERRACE AVENUE BATON ROUGE, LOUISIANA 70802		REV.	DATE	BY
MARSH CREATION BORROW AREA SECTIONS		STATE PROJECT NUMBER: BA-0125	DESIGNED BY: T. MCLAIN, E.I.	
		DRAWN BY: K. CANTU		APPROVED BY: T. FITZGERALD, P.E. P.E. NO. 38153
NORTHWEST TURTLE BAY MARSH CREATION PROJECT		DATE: DEC. 2018		SHEET 37 OF 79

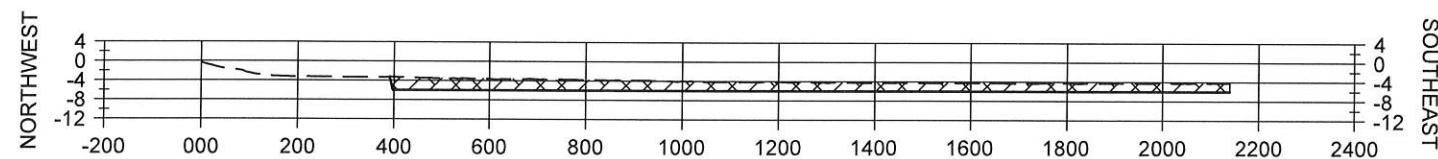

A1

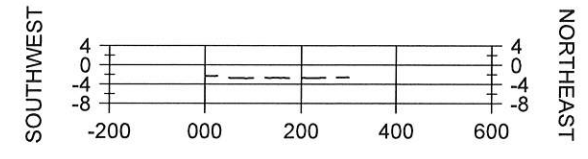

A2

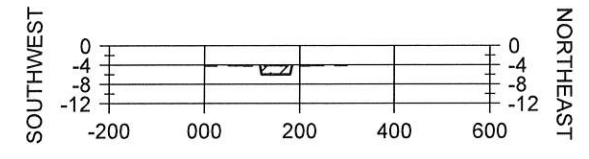

A3

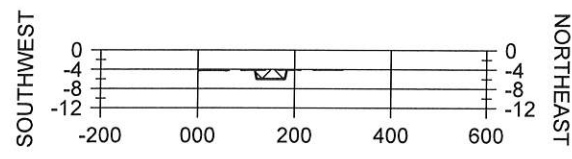

A4

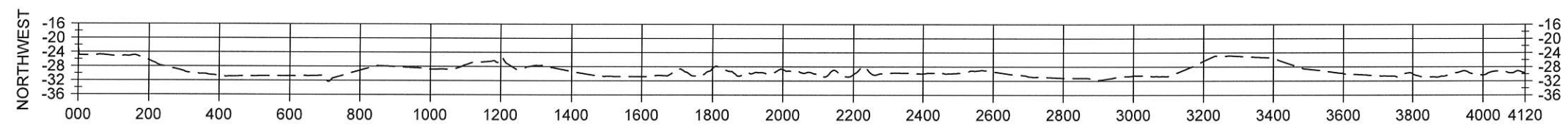

A5

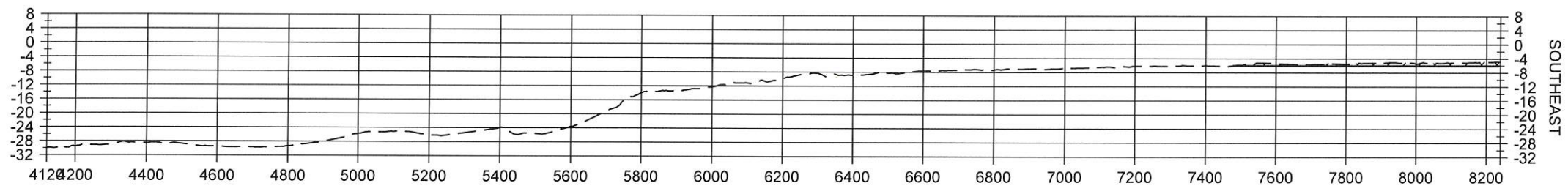

A5 CONTINUED

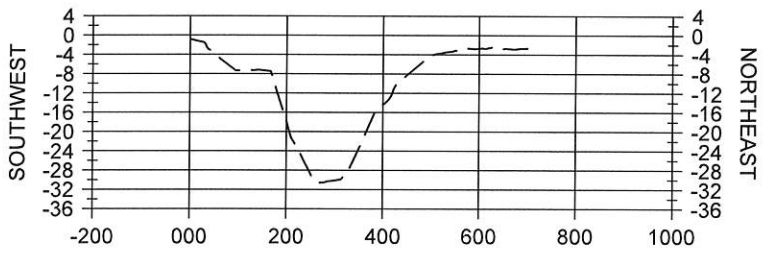

A6

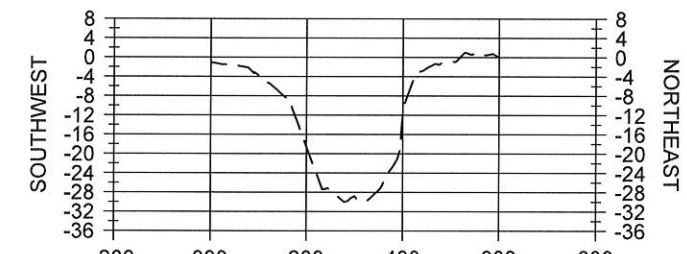

A7

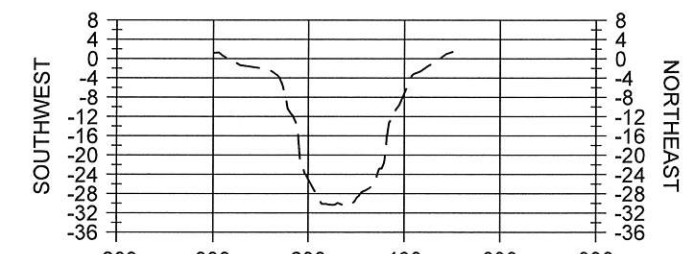

A8

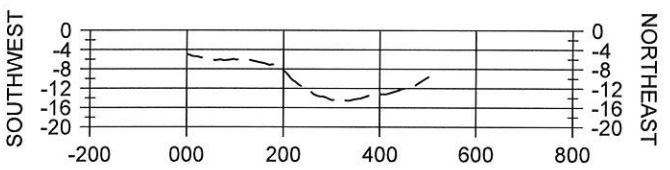

A9

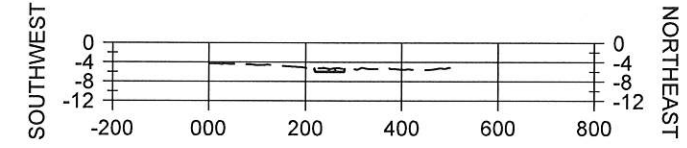

A10

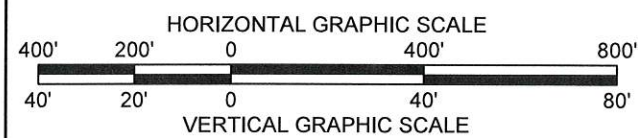

LEGEND	
	WATER BOTTOM
	MARSH CREATION BORROW AREA



NOTE:
ALL ELEVATIONS ARE GIVEN IN THE NORTH AMERICAN
VERTICAL DATUM OF 1988 (NAVD88) GEOID 12A.

COASTAL PROTECTION AND RESTORATION AUTHORITY 150 TERRACE AVENUE BATON ROUGE, LOUISIANA 70802		REV.	DATE	DESCRIPTION	BY
EQUIPMENT ACCESS CHANNEL SECTIONS		DESIGNED BY: T. MCCLAIN, E.I.		P.E. NO. 38153	
NORTHWEST TURTLE BAY MARSH CREATION PROJECT		STATE PROJECT NUMBER: BA-0125		DRAWN BY: K. CANTU	
		APPROVED BY: T. FITZGERALD, P.E.			
		DATE: DEC. 2018			
		SHEET 38 OF 79			

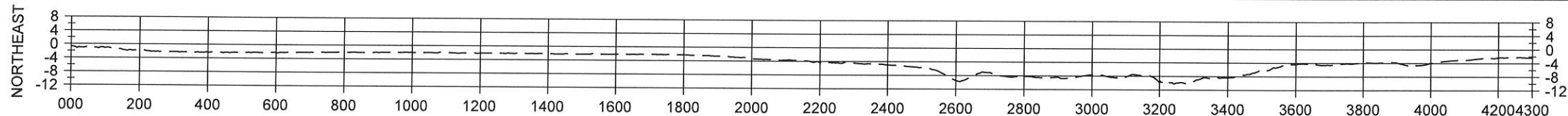

A11

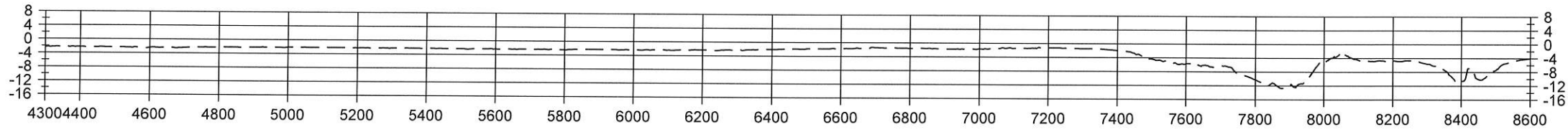

A11 CONTINUED

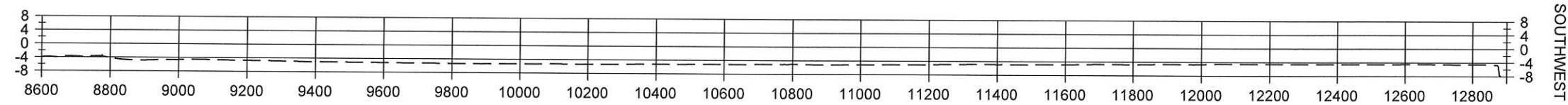

A11 CONTINUED

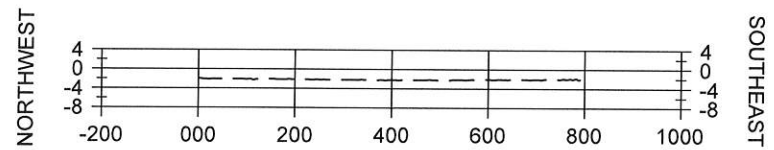

A12

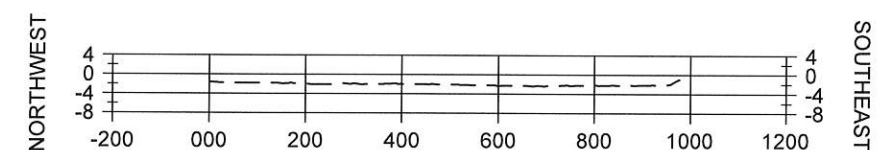

A13

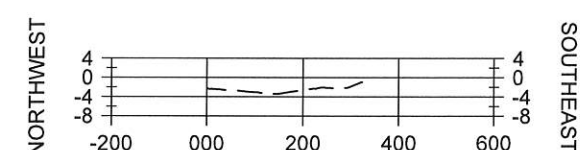

A14

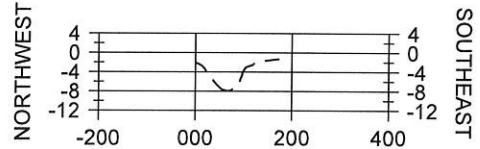

A15

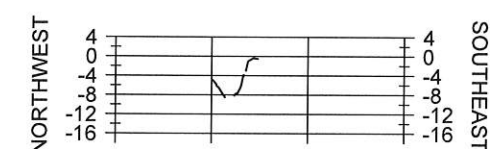

A16

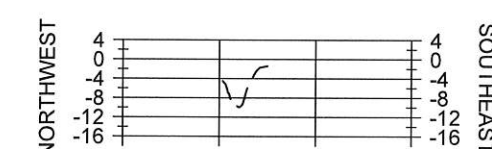

A17

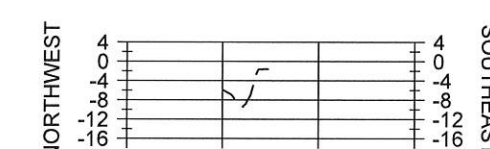

A18

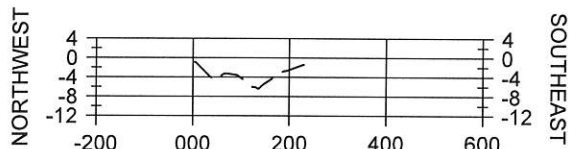

A19



A20

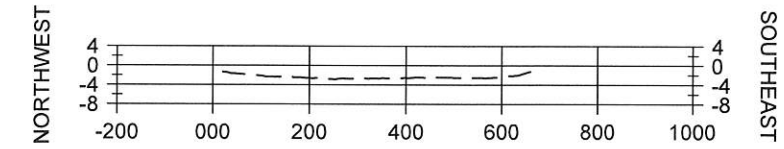

A21

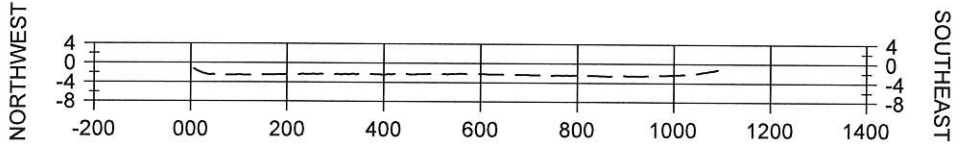

A22

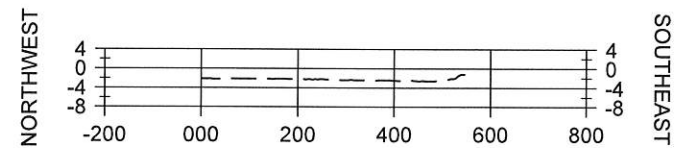

A23

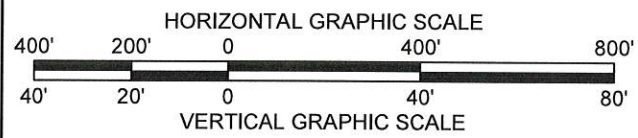

LEGEND	
---	WATER BOTTOM



NOTE:
ALL ELEVATIONS ARE GIVEN IN THE NORTH AMERICAN
VERTICAL DATUM OF 1988 (NAVD88) GEOID 12A.

COASTAL PROTECTION AND RESTORATION AUTHORITY 150 TERRACE AVENUE BATON ROUGE, LOUISIANA 70802		REV.	DATE	DESCRIPTION	BY
EQUIPMENT ACCESS CHANNEL SECTIONS					
NORTHWEST TURTLE BAY MARSH CREATION PROJECT					
STATE PROJECT NUMBER: BA-0125		DESIGNED BY: T. MCCLAIN, E.I.		APPROVED BY: T. FITZGERALD, P.E. P.E. NO. 38153	
DRAWN BY: K. CANTU					
DATE: DEC. 2018					
SHEET 39 OF 79					

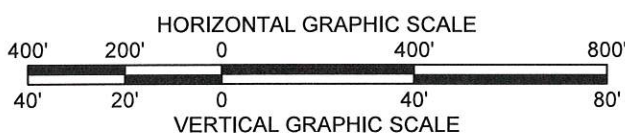
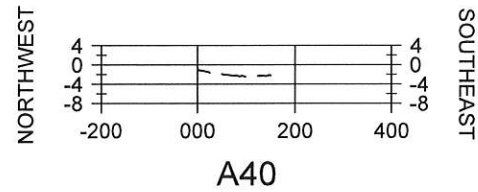
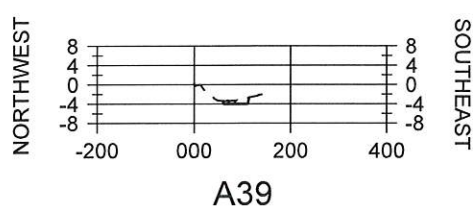
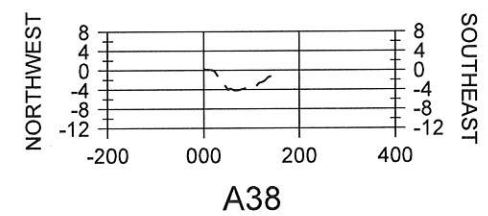
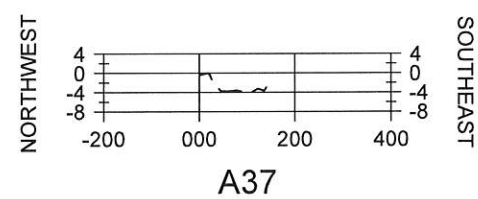
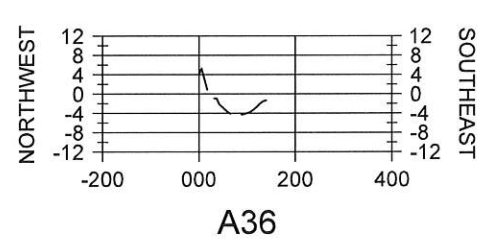
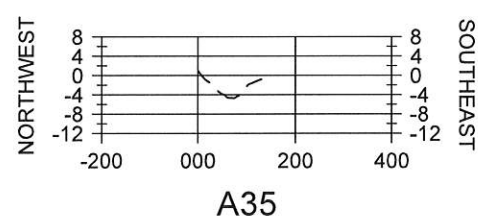
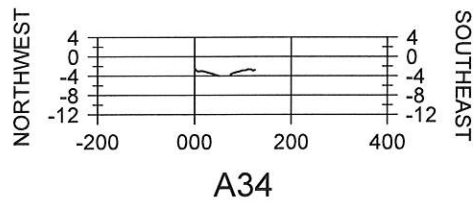
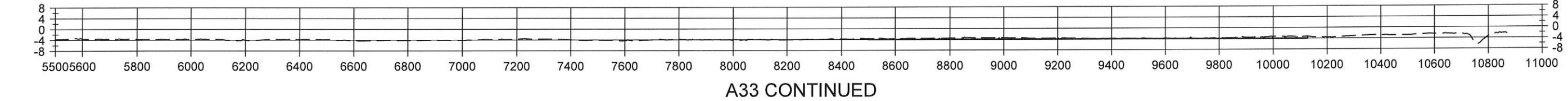
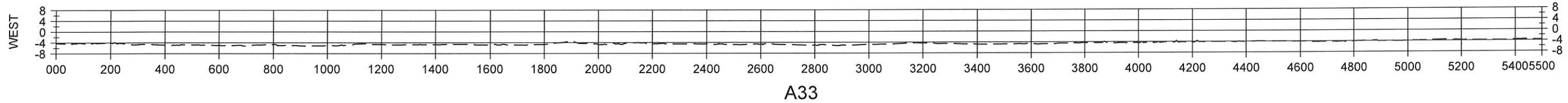
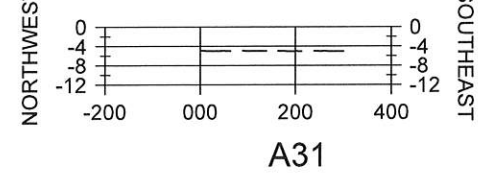
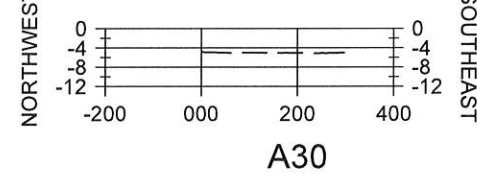
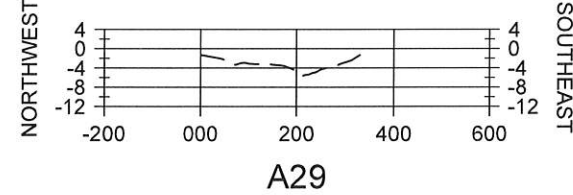
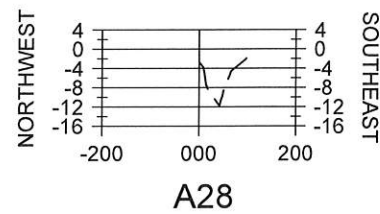
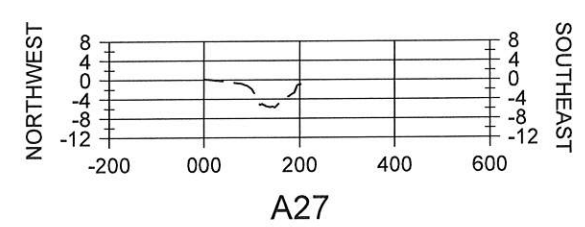
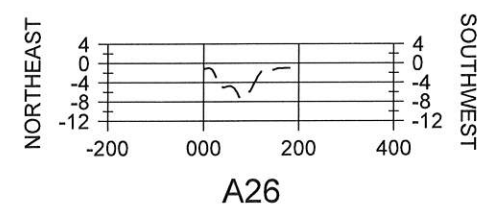
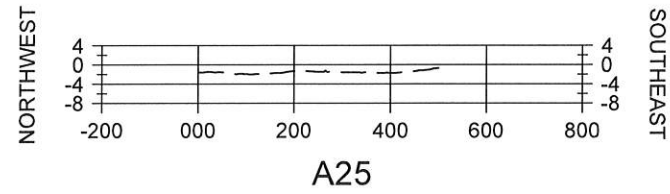
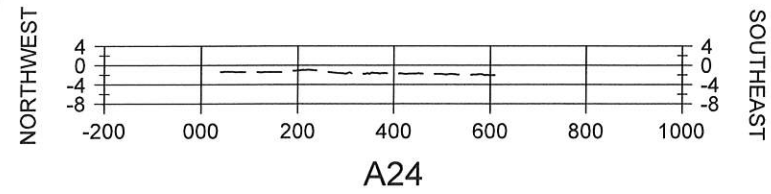

LEGEND	
---	WATER BOTTOM

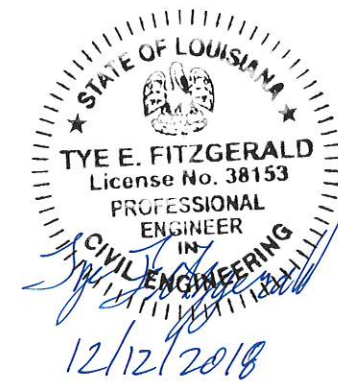

NOTE:
ALL ELEVATIONS ARE GIVEN IN THE NORTH AMERICAN
VERTICAL DATUM OF 1988 (NAVD88) GEOID 12A.

COASTAL PROTECTION AND RESTORATION AUTHORITY 150 TERRACE AVENUE BATON ROUGE, LOUISIANA 70802		DESIGNED BY: T. MCLAIN, E.I.	APPROVED BY: T. FITZGERALD, P.E. P.E. NO. 38153
EQUIPMENT ACCESS CHANNEL SECTIONS		STATE PROJECT NUMBER: BA-0125	DRAWN BY: K. CANTU
NORTHWEST TURTLE BAY MARSH CREATION PROJECT		DATE: DEC. 2018	SHEET 40 OF 79
REV.	DATE	DESCRIPTION	BY

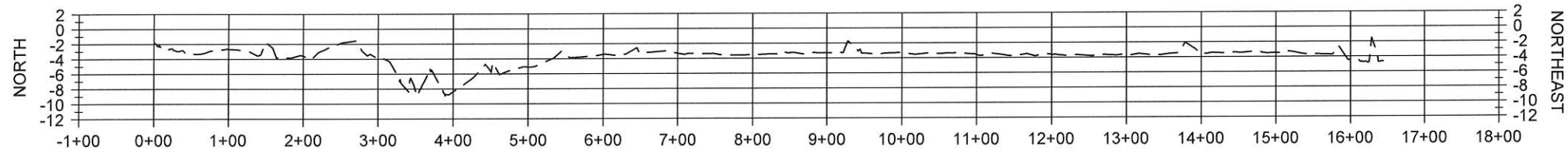

AR1 PROFILE

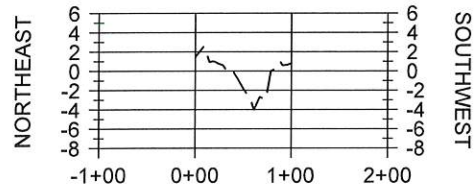

AR1-1 PROFILE

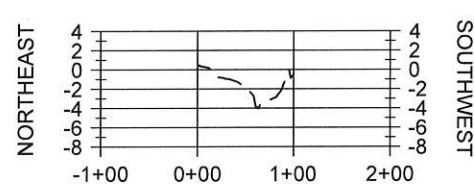

AR1-2 PROFILE

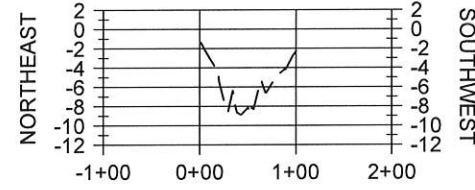

AR1-3 PROFILE

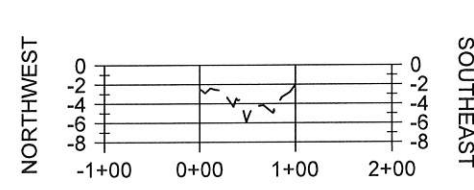

AR1-4 PROFILE

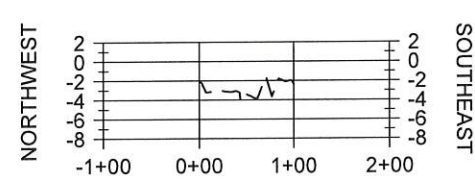

AR1-5 PROFILE

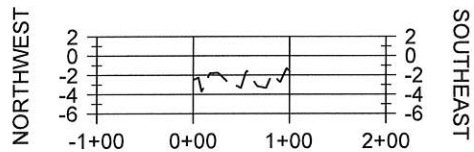

AR1-6 PROFILE

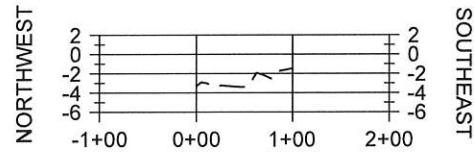

AR1-7 PROFILE

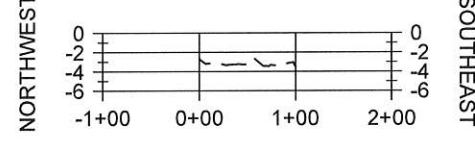

AR1-8 PROFILE

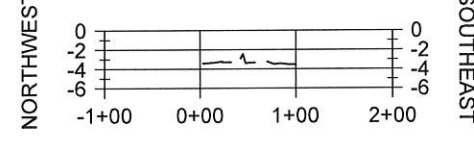

AR1-9 PROFILE

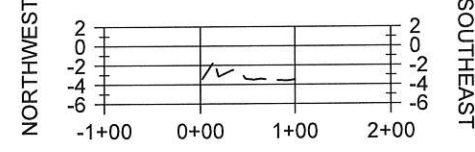

AR1-10 PROFILE

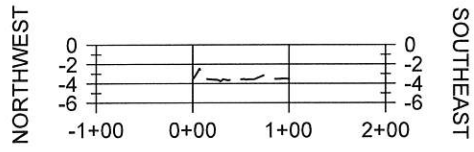

AR1-11 PROFILE

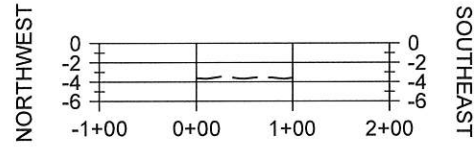

AR1-12 PROFILE

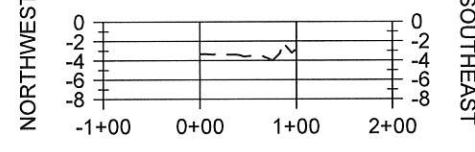

AR1-13 PROFILE

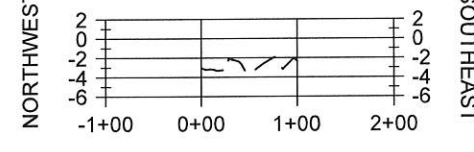

AR1-14 PROFILE

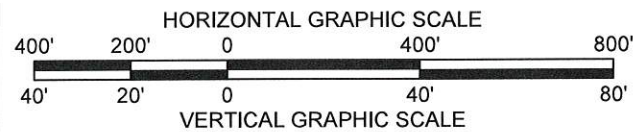

LEGEND	
---	WATER BOTTOM



NOTE:
ALL ELEVATIONS ARE GIVEN IN THE NORTH AMERICAN
VERTICAL DATUM OF 1988 (NAVD88) GEOID 12A.

COASTAL PROTECTION AND RESTORATION AUTHORITY 150 TERRACE AVENUE BATON ROUGE, LOUISIANA 70802		REVISIONS	DATE	BY
EQUIPMENT ACCESS CHANNEL SECTIONS				
DESIGNED BY: T. MCLAIN, E.I.		APPROVED BY: T. FITZGERALD, P.E. P.E. NO. 38153		
DRAWN BY: K. CANTU				
NORTHWEST TURTLE BAY MARSH CREATION PROJECT		STATE PROJECT NUMBER: BA-0125		
DATE: DEC. 2018		SHEET 41 OF 79		

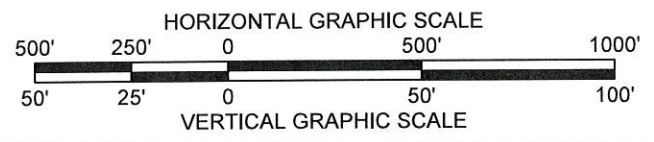
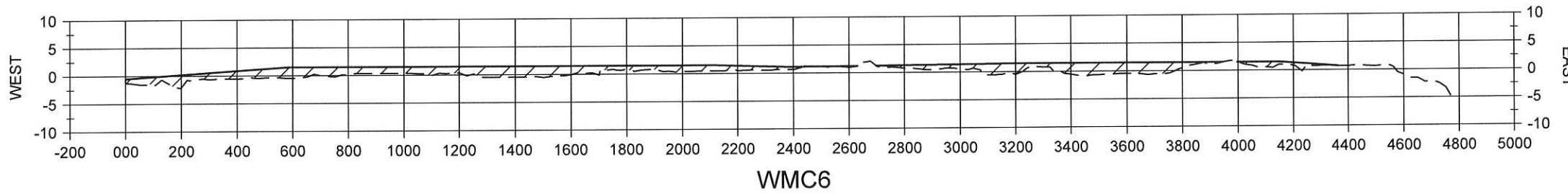
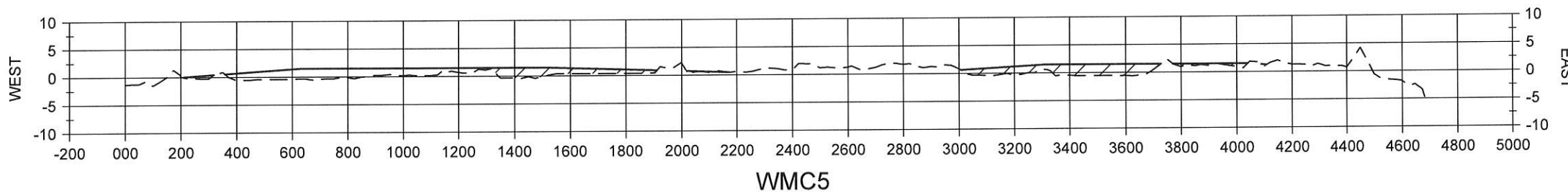
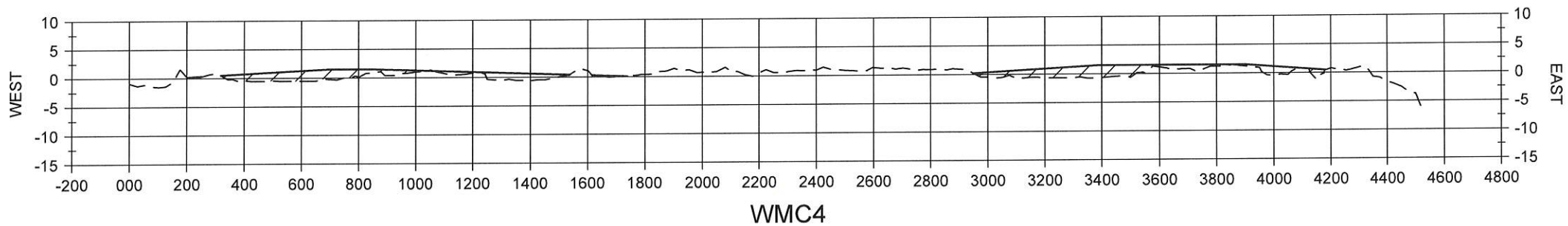
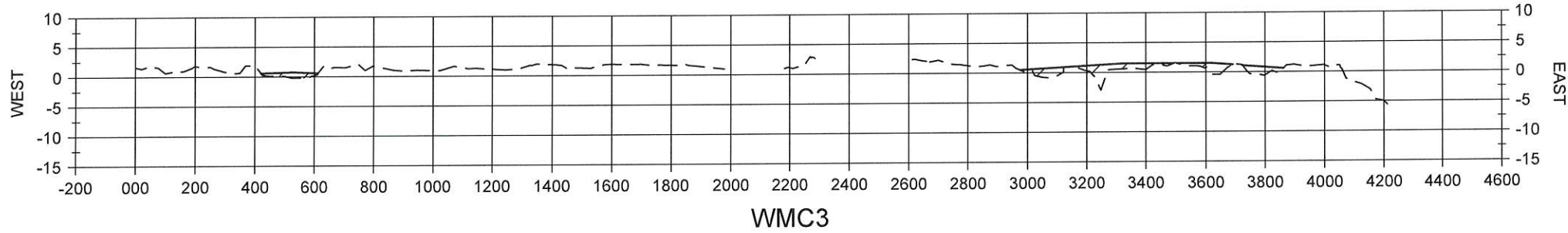
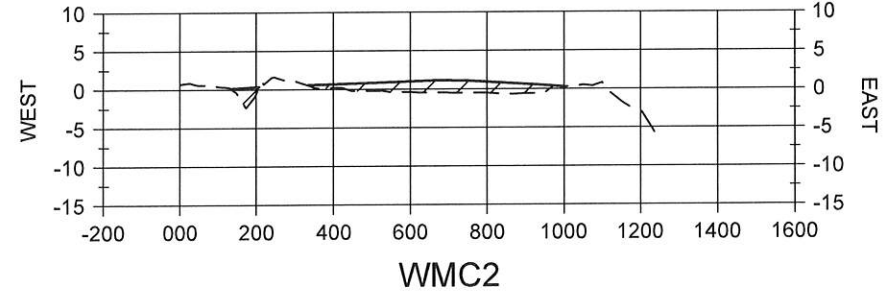
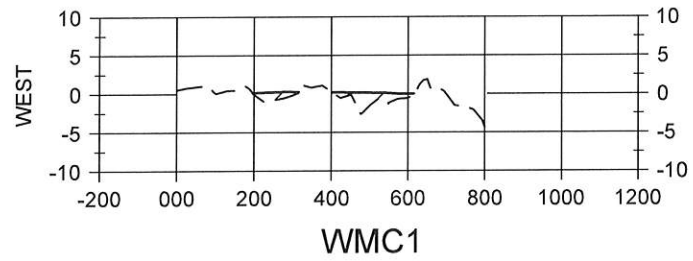

NOTE:
ALL ELEVATIONS ARE GIVEN IN THE NORTH AMERICAN
VERTICAL DATUM OF 1988 (NAVD88) GEOID 12A.

LEGEND	
	MARSH CREATION FILL
	EXISTING GROUND/WATER BOTTOM



COASTAL PROTECTION AND RESTORATION AUTHORITY 150 TERRACE AVENUE BATON ROUGE, LOUISIANA 70802		DATE	DESCRIPTION	BY
WEST MARSH CREATION AREA SECTIONS		REV.		
NORTHWEST TURTLE BAY MARSH CREATION PROJECT		DATE: DEC. 2018		
DESIGNED BY: T. MCLAIN, E.I.	APPROVED BY: T. FITZGERALD, P.E.	P. E. NO. 38153		
STATE PROJECT NUMBER: BA-0125	DRAWN BY: K. CANTU			
		SHEET 42 OF 79		

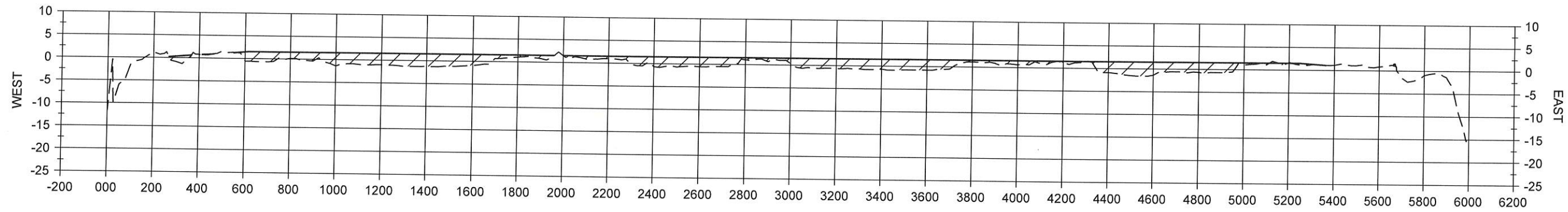

WMC12

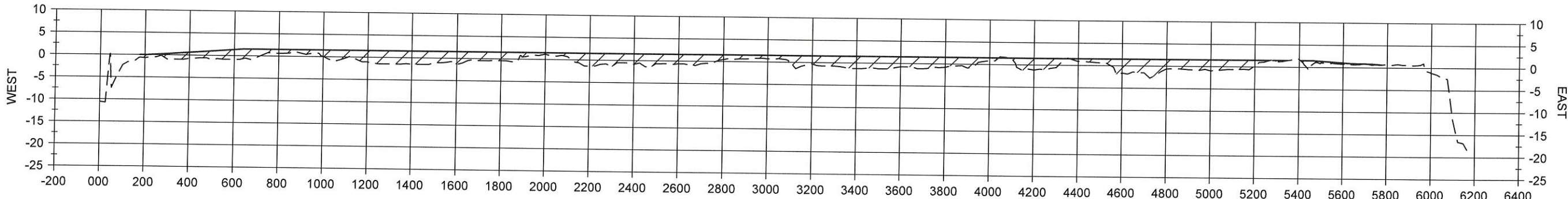

WMC13

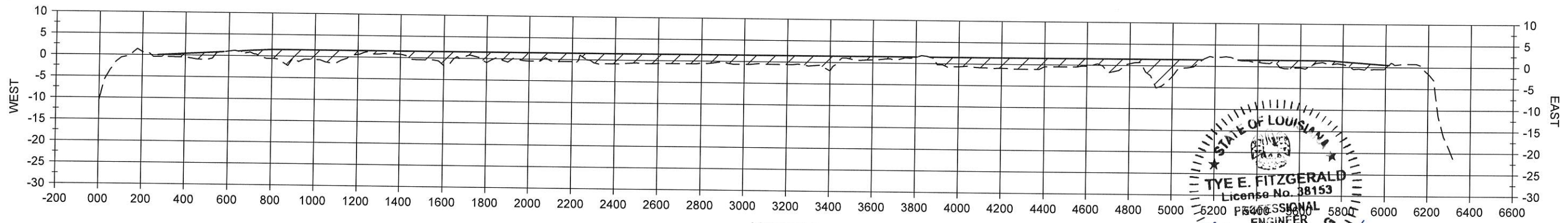

WMC14

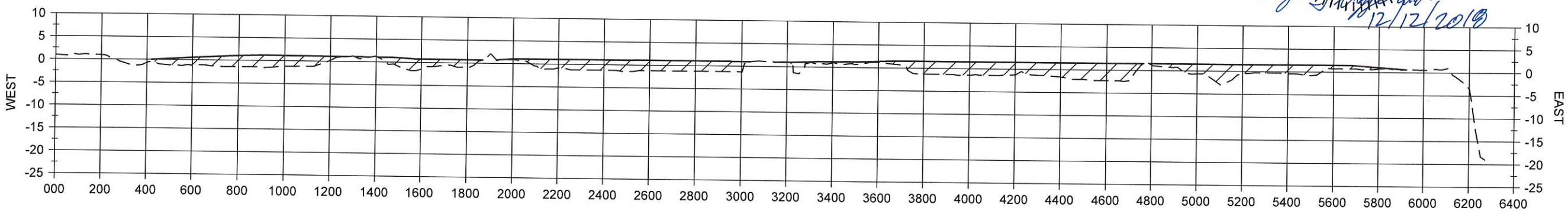

WMC15

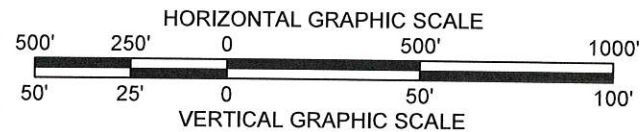

NOTE:
ALL ELEVATIONS ARE GIVEN IN THE NORTH AMERICAN
VERTICAL DATUM OF 1988 (NAVD88) GEOID 12A.

LEGEND	
	MARSH CREATION FILL
	EXISTING GROUND/WATER BOTTOM

COASTAL PROTECTION AND RESTORATION AUTHORITY 150 TERRACE AVENUE BATON ROUGE, LOUISIANA 70802	
WEST MARSH CREATION AREA SECTIONS	DESIGNED BY: T. MCLAIN, E.I. APPROVED BY: T. FITZGERALD, P.E. P.E. NO. 38153
NORTHWEST TURTLE BAY MARSH CREATION PROJECT	STATE PROJECT NUMBER: BA-0125 DRAWN BY: K. CANTU
DATE: DEC. 2018	BY:
SHEET 44 OF 79	DESCRIPTION:
	DATE:
	REV.

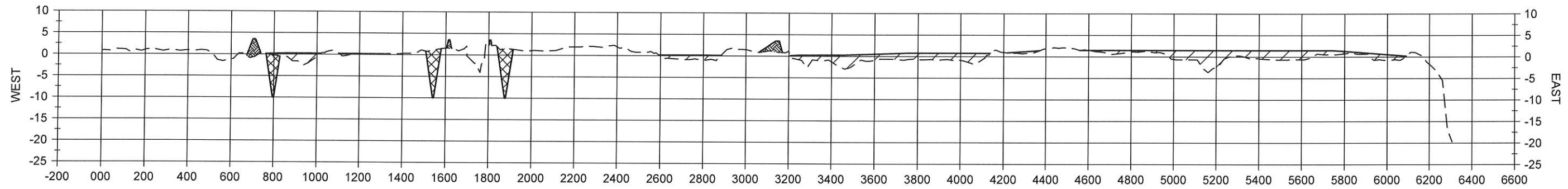

WMC16

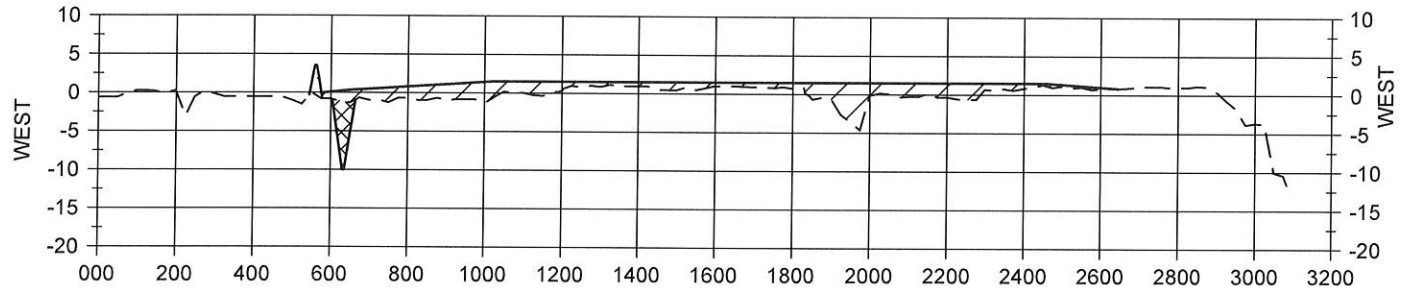

WMC17

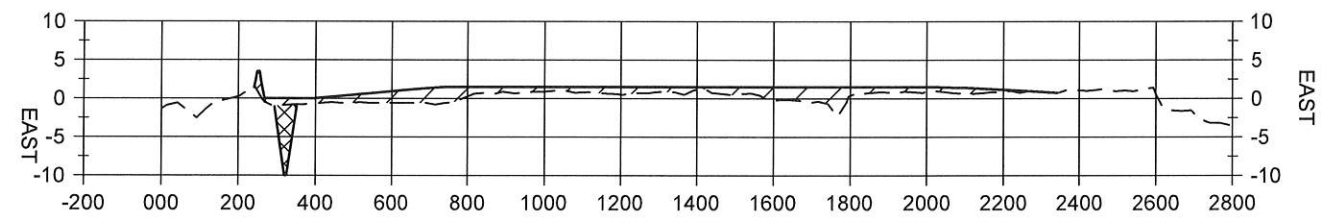

WMC18

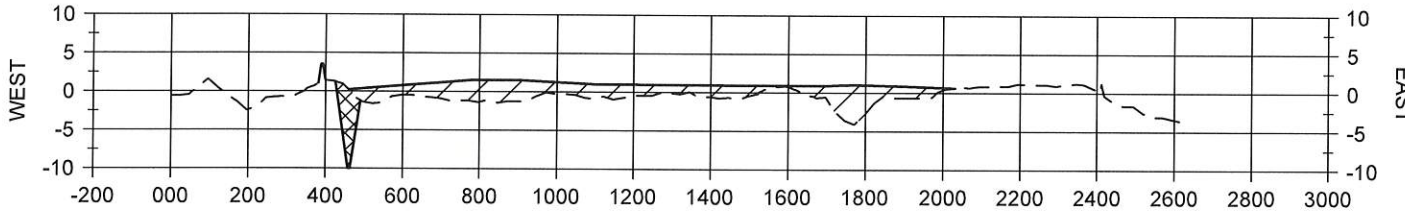

WMC19

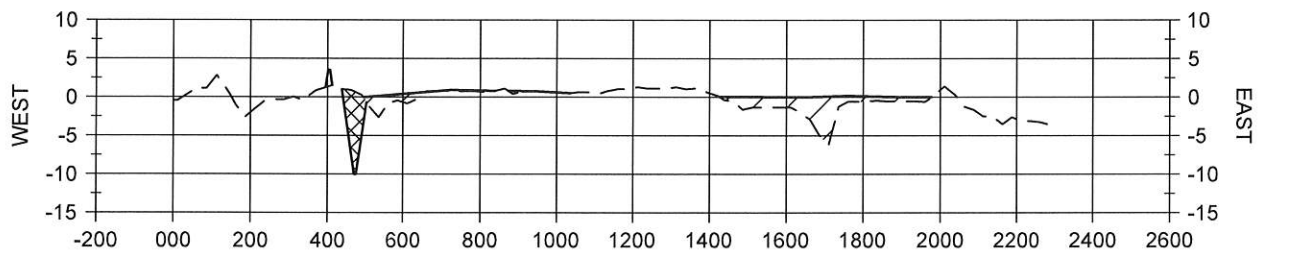

WMC20

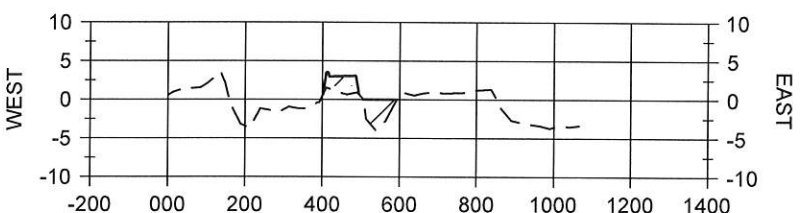

WMC21

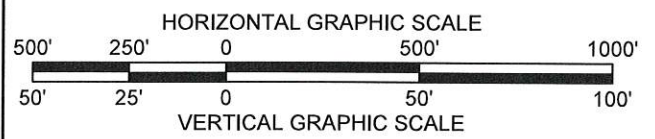

NOTE:
ALL ELEVATIONS ARE GIVEN IN THE NORTH AMERICAN
VERTICAL DATUM OF 1988 (NAVD88) GEOID 12A.

12/12/2018

LEGEND

- EARTHEN CONTAINMENT DIKE
- BORROW AREA
- EARTHEN GAP CLOSURE
- MARSH CREATION FILL
- EXISTING GROUND/WATER BOTTOM

COASTAL PROTECTION AND RESTORATION AUTHORITY 150 TERRACE AVENUE BATON ROUGE, LOUISIANA 70802	WEST MARSH CREATION AREA SECTIONS NORTHWEST TURTLE BAY MARSH CREATION PROJECT
DESIGNED BY: T. MCCLAIN, E.I. APPROVED BY: T. FITZGERALD, P.E. P.E. NO. 38153	STATE PROJECT NUMBER: BA-0125 DRAWN BY: K. CANTU
DATE: DEC. 2018	
SHEET 45 OF 79	

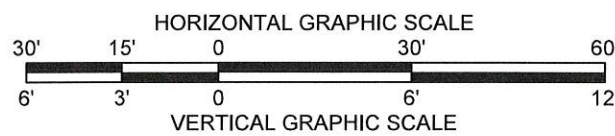
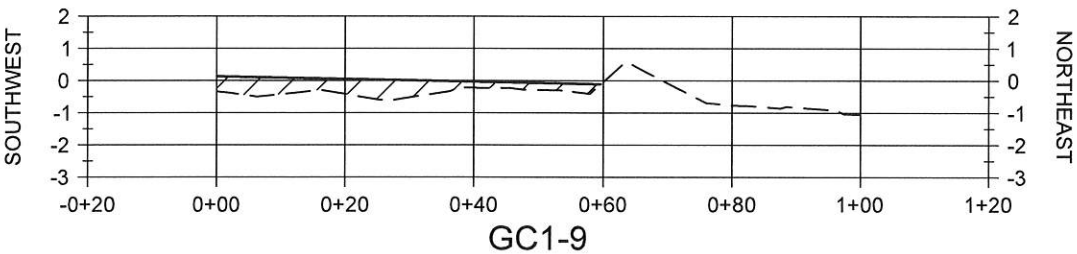
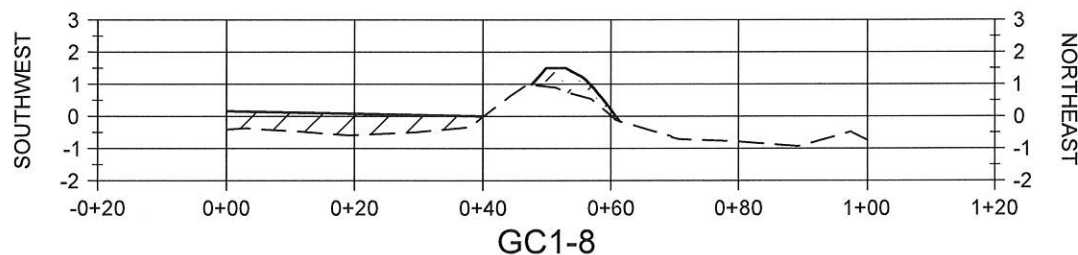
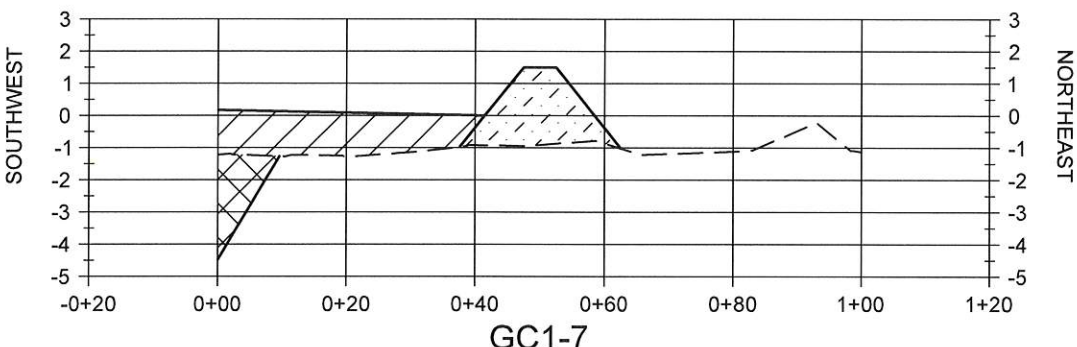
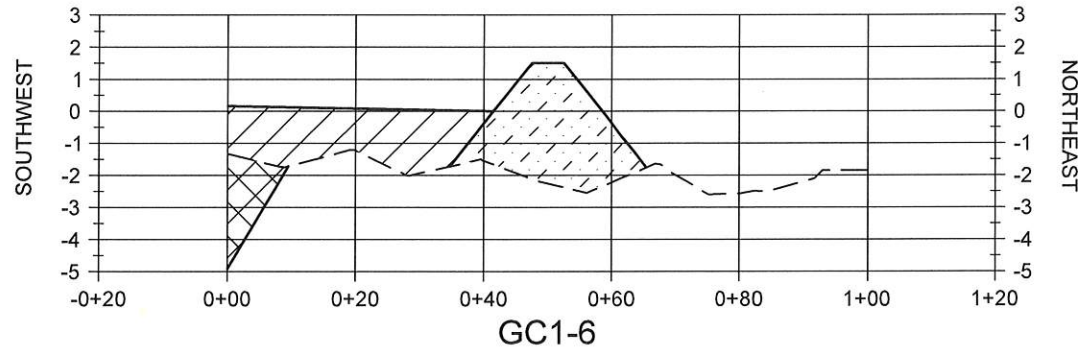
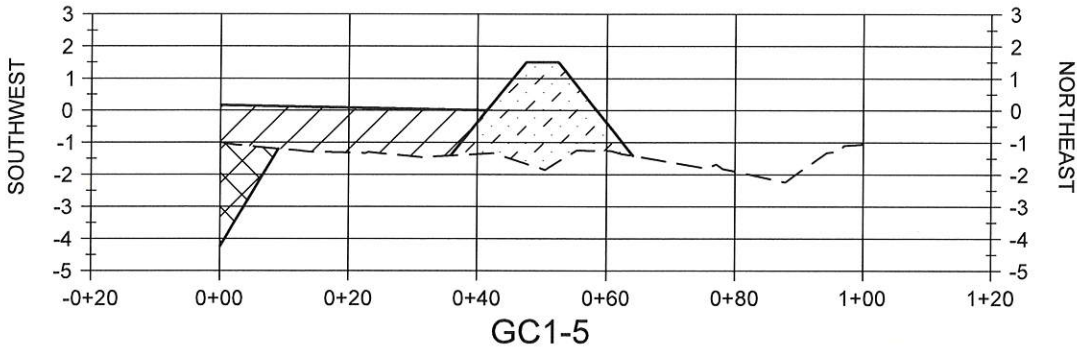
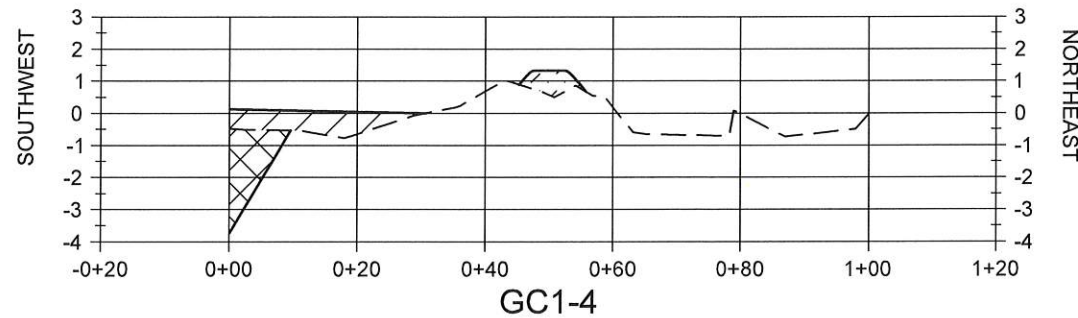
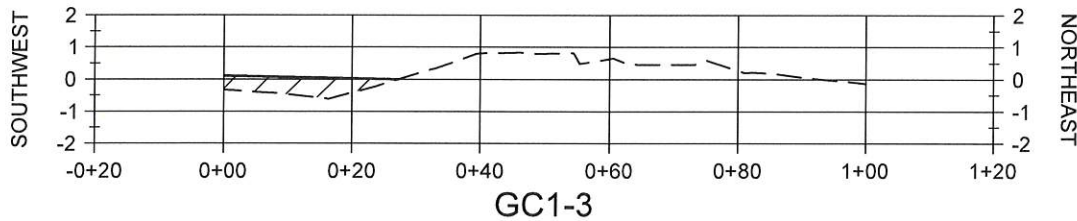
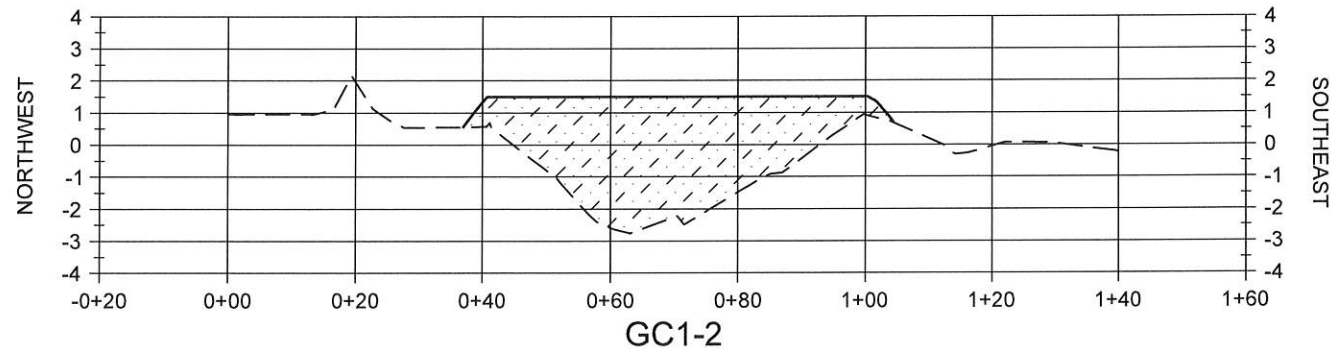
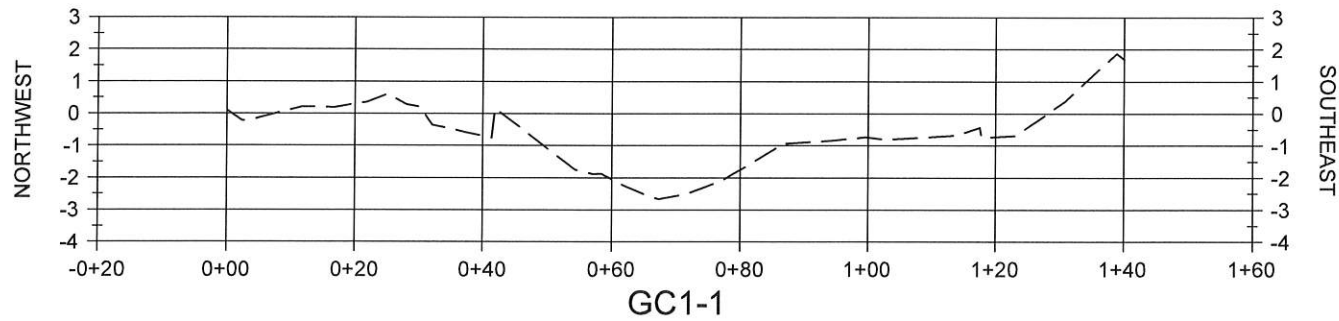

NOTE:
ALL ELEVATIONS ARE GIVEN IN THE NORTH AMERICAN
VERTICAL DATUM OF 1988 (NAVD88) GEOID 12A.



LEGEND	
	EARTHEN GAP CLOSURE
	EARTHEN GAP CLOSURE BORROW AREA
	MARSH CREATION FILL
	EXISTING GRADE

COASTAL PROTECTION AND RESTORATION AUTHORITY 150 TERRACE AVENUE BATON ROUGE, LOUISIANA 70802		REV.	DATE	BY
WEST MARSH CREATION AREA SECTIONS		DESIGNED BY: T. MCCLAIN, E.I.	APPROVED BY: T. FITZGERALD, P.E.	P.E. NO. 38153
NORTHWEST TURTLE BAY MARSH CREATION PROJECT		STATE PROJECT NUMBER: BA-0125	DRAWN BY: K. CANTU	
DATE: DEC. 2018				
SHEET 46 OF 79				

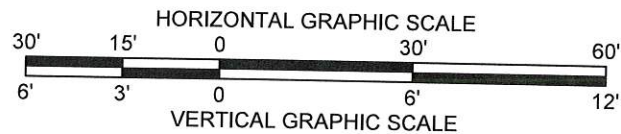
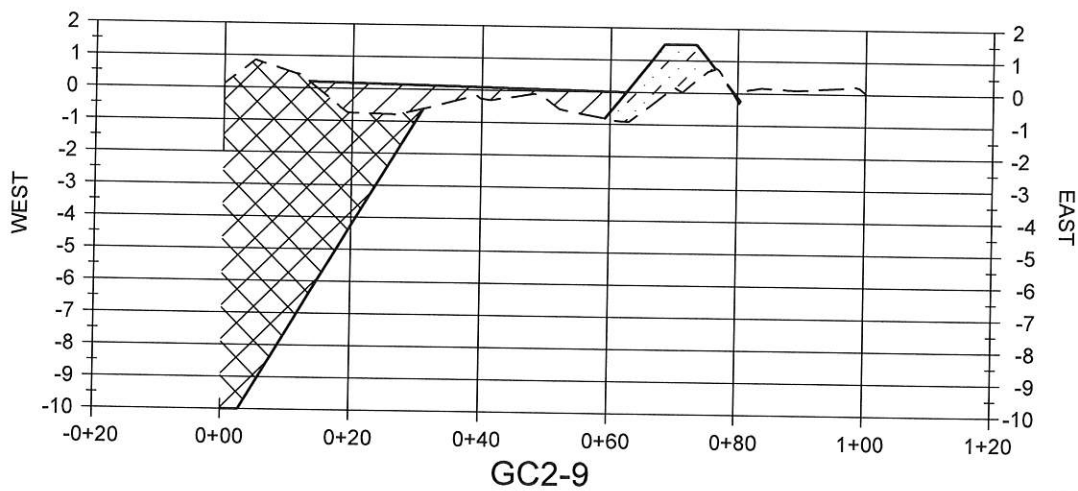
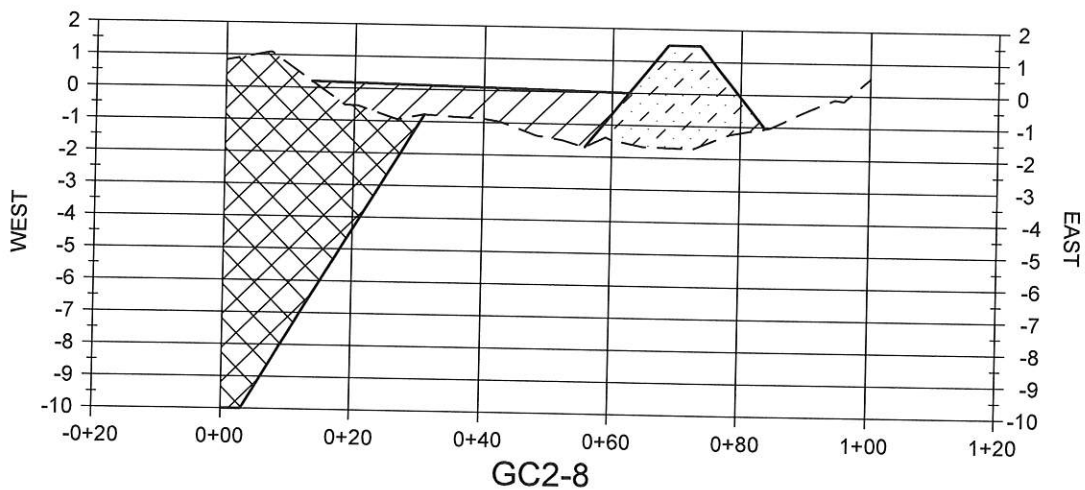
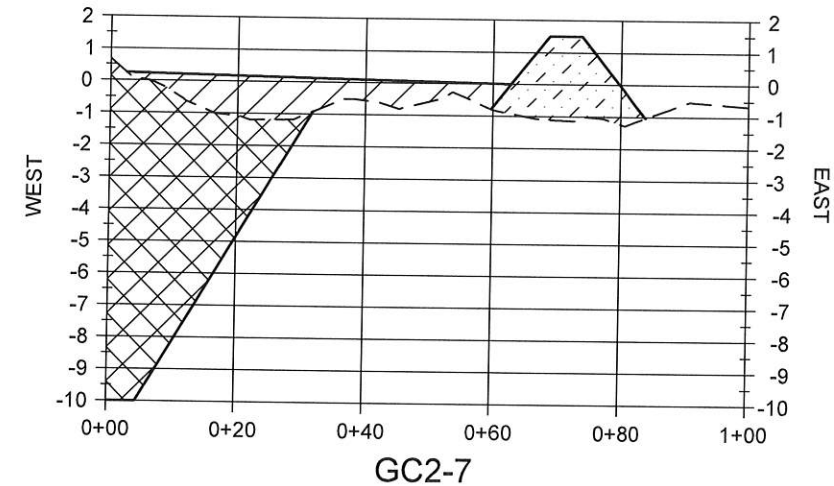
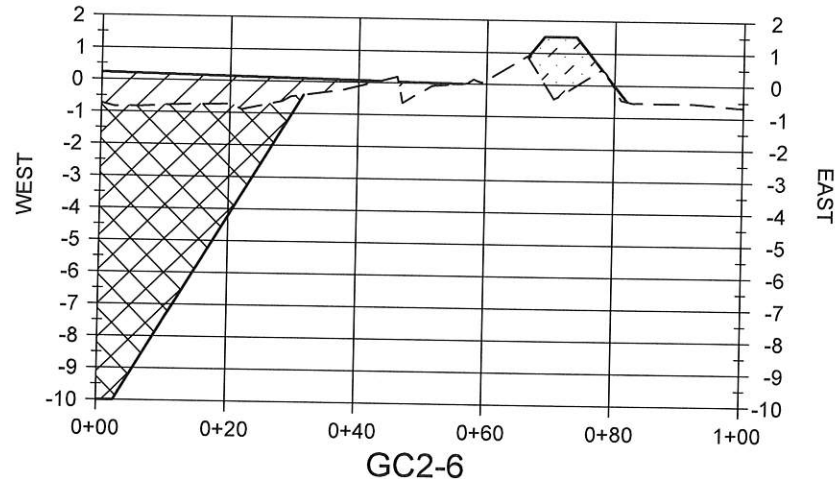
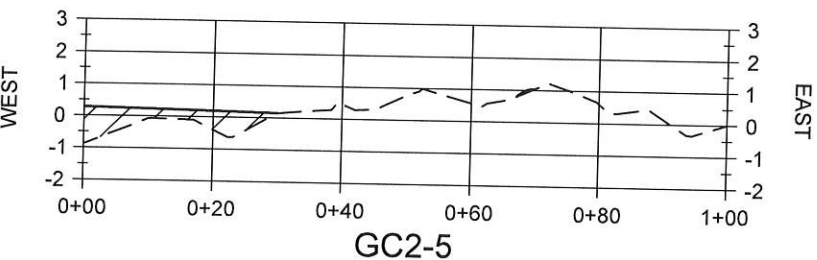
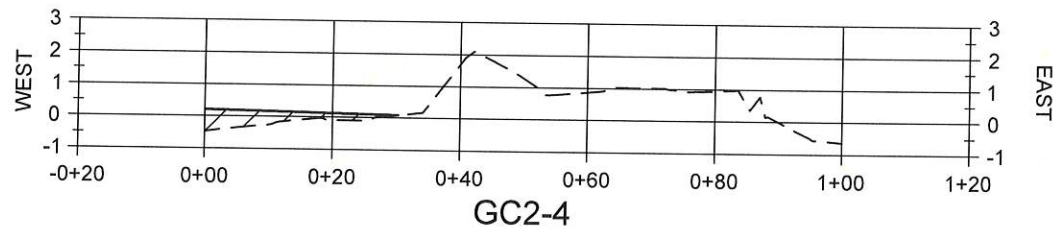
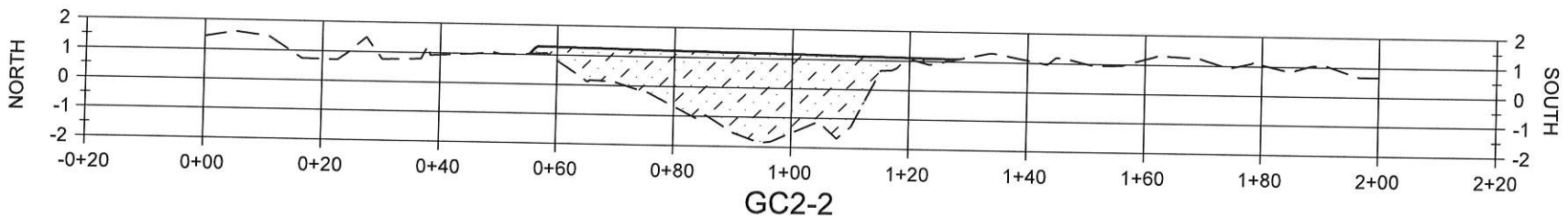
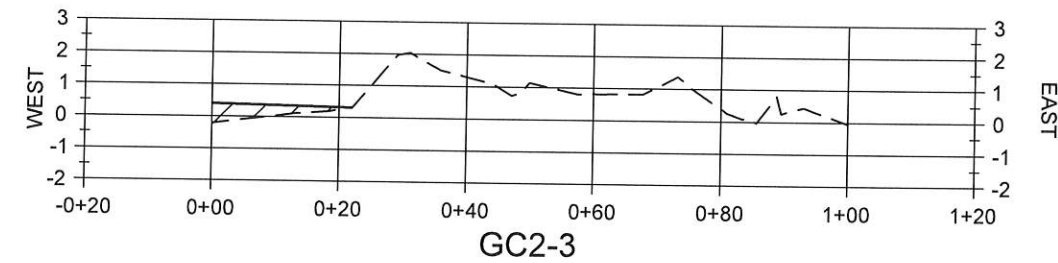
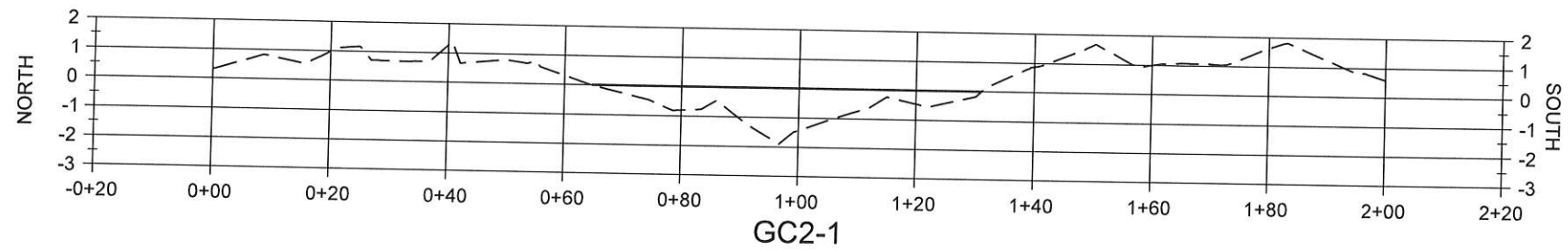

NOTE:
ALL ELEVATIONS ARE GIVEN IN THE NORTH AMERICAN
VERTICAL DATUM OF 1988 (NAVD88) GEOID 12A.

LEGEND	
	EARTHEN GAP CLOSURE
	EARTHEN GAP CLOSURE BORROW AREA
	MARSH CREATION FILL
	EXISTING GRADE

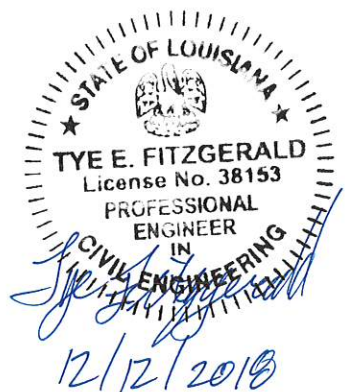

REV.	DATE	DESCRIPTION	BY

COASTAL PROTECTION AND
RESTORATION AUTHORITY
150 TERRACE AVENUE
BATON ROUGE, LOUISIANA 70802

WEST MARSH CREATION
AREA SECTIONS

DESIGNED BY: T. MCLAIN, E.I.
APPROVED BY: T. FITZGERALD, P.E. P.E. NO. 38153

NORTHWEST TURTLE BAY
MARSH CREATION PROJECT

STATE PROJECT NUMBER: BA-0125
DRAWN BY: K. CANTU

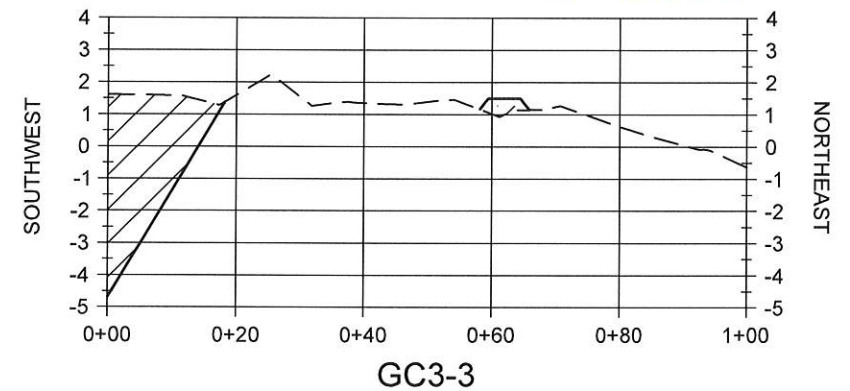
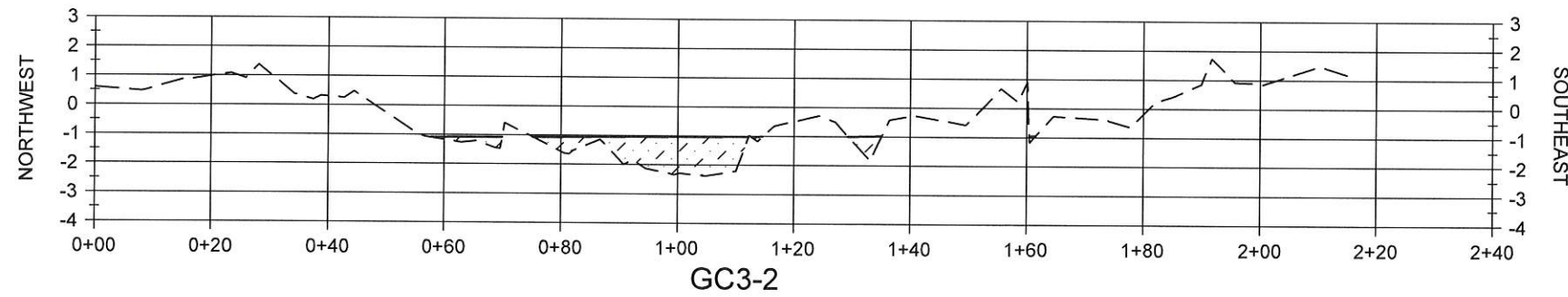
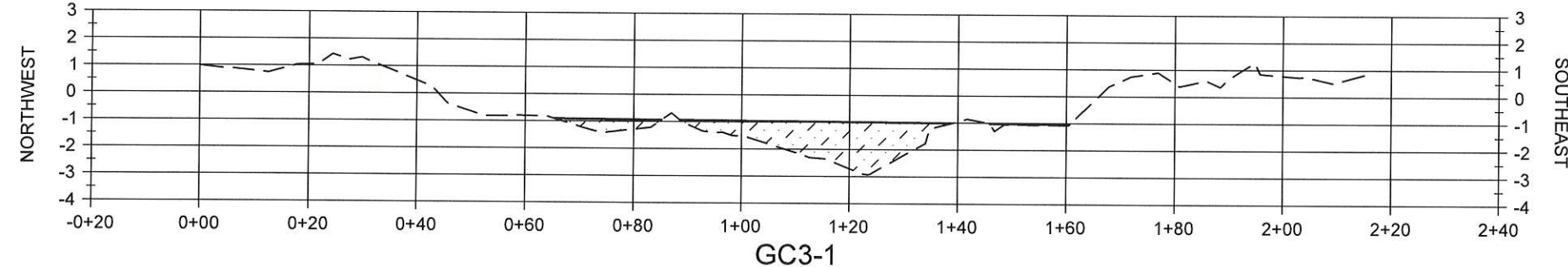
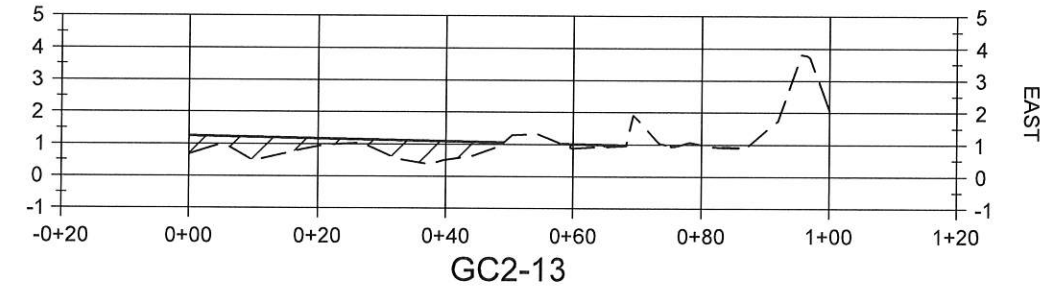
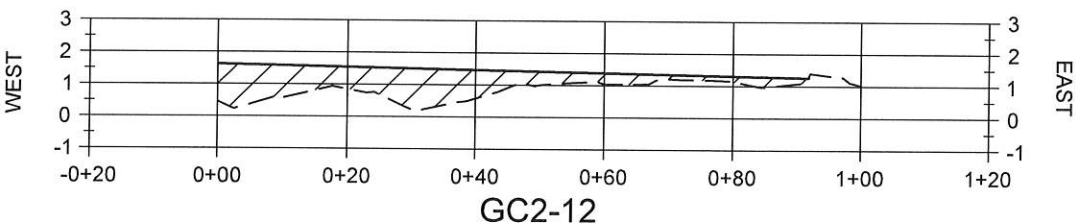
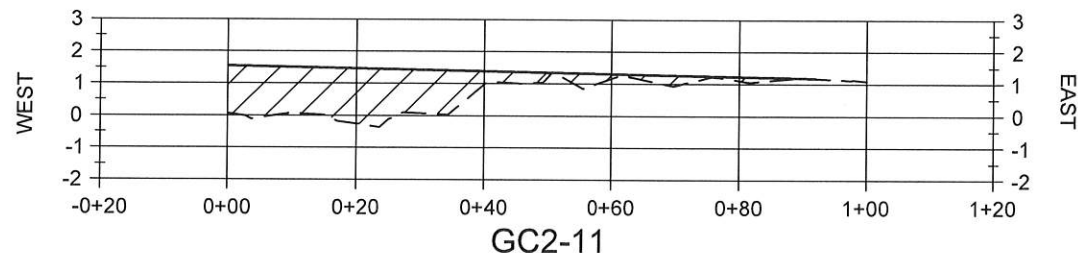
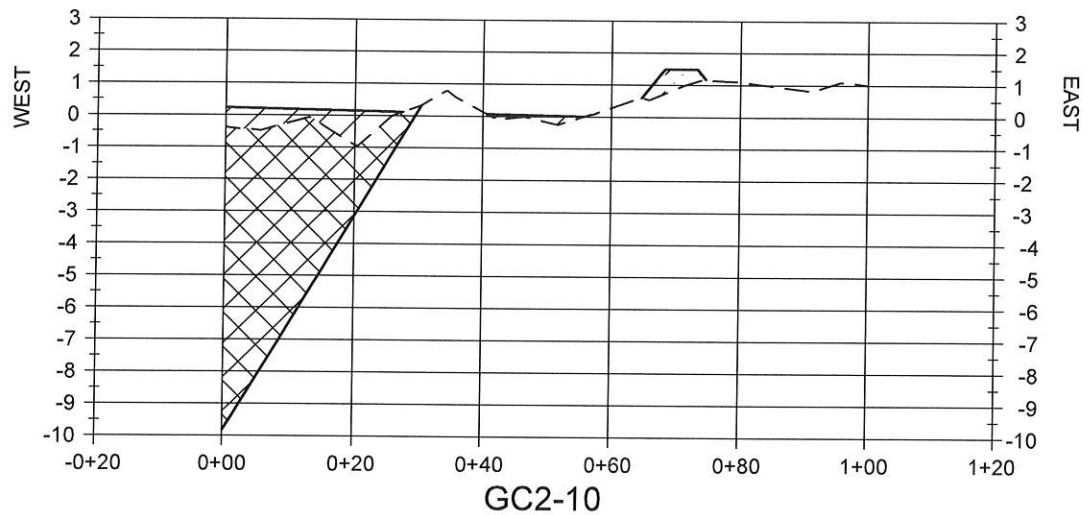

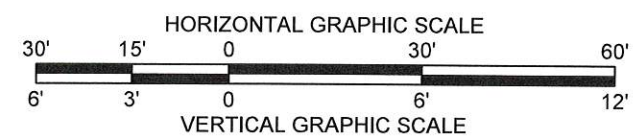

 TYE E. FITZGERALD
 License No. 38153
 PROFESSIONAL ENGINEER
 IN
 CIVIL ENGINEERING
 12/12/2018



NOTE:
 ALL ELEVATIONS ARE GIVEN IN THE NORTH AMERICAN
 VERTICAL DATUM OF 1988 (NAVD88) GEOID 12A.

LEGEND	
	EARTHEN GAP CLOSURE
	EARTHEN GAP CLOSURE BORROW AREA
	MARSH CREATION FILL
	EXISTING GRADE

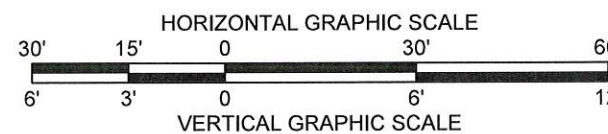
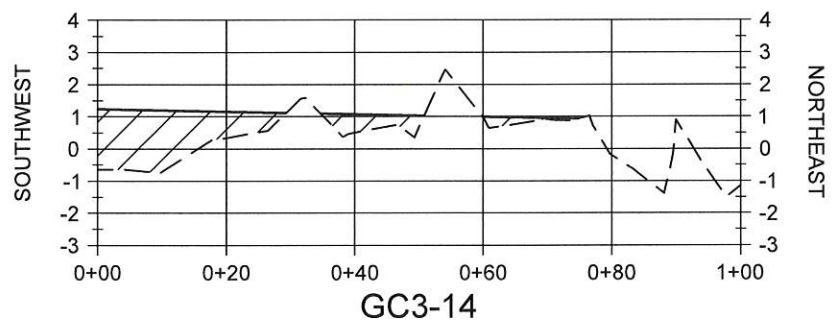
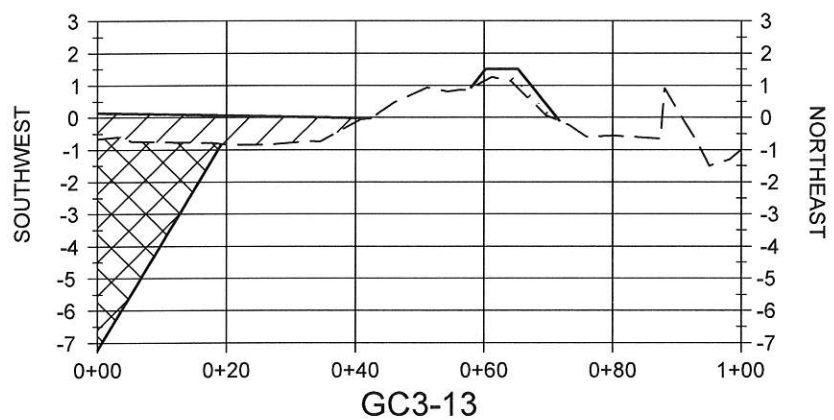
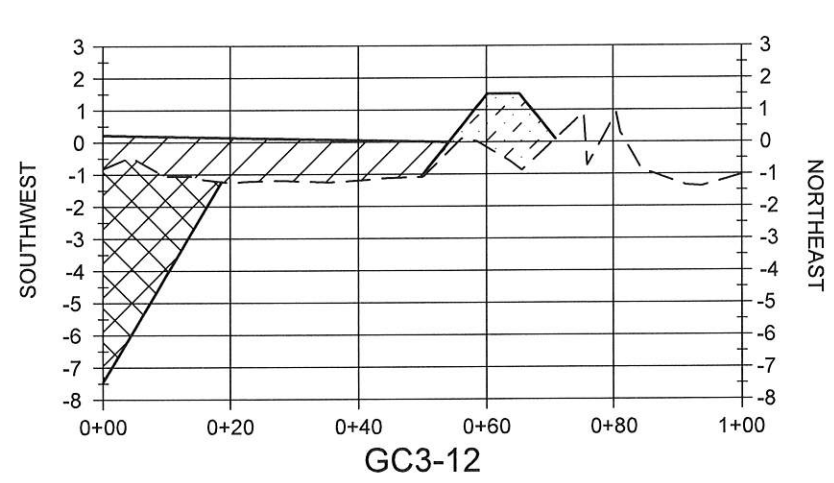
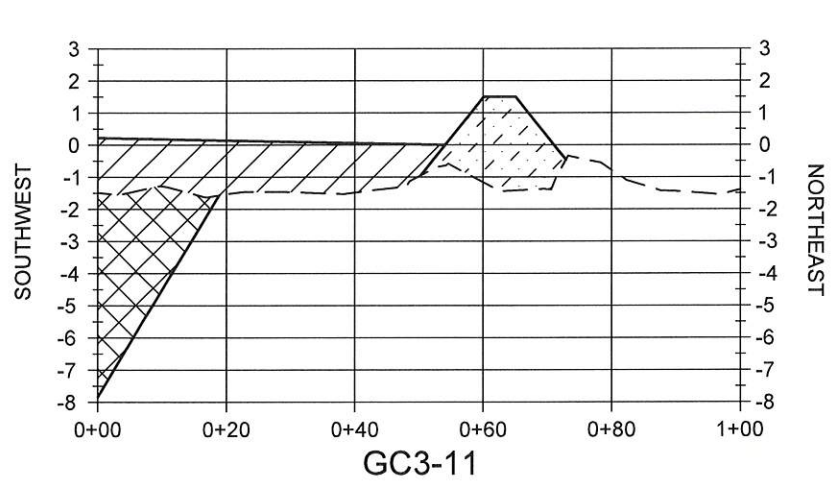
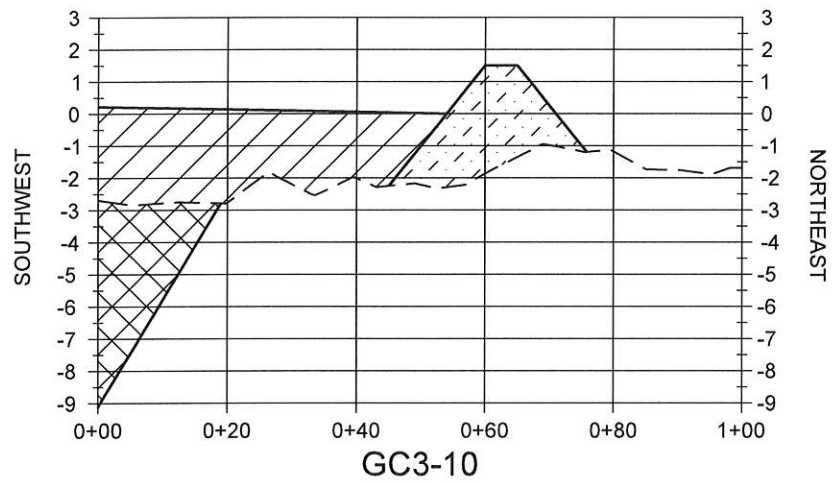
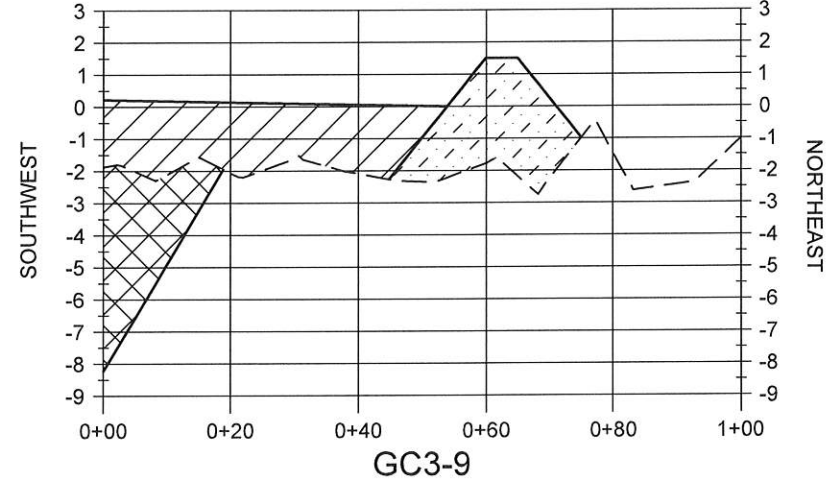
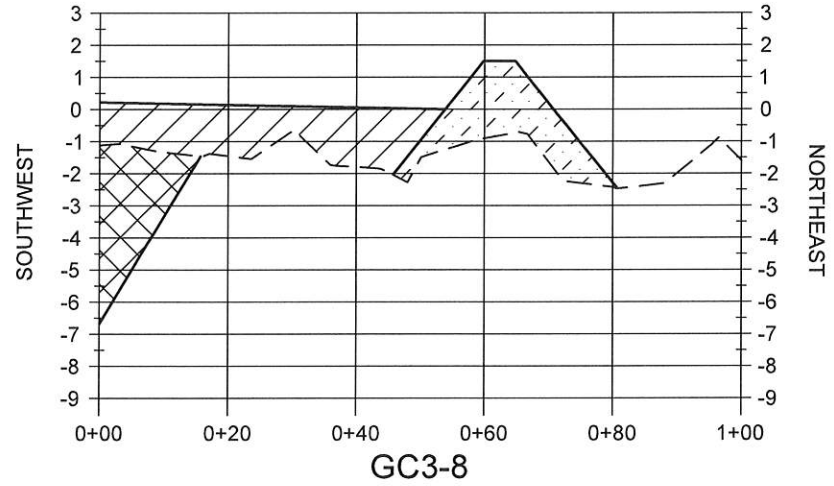
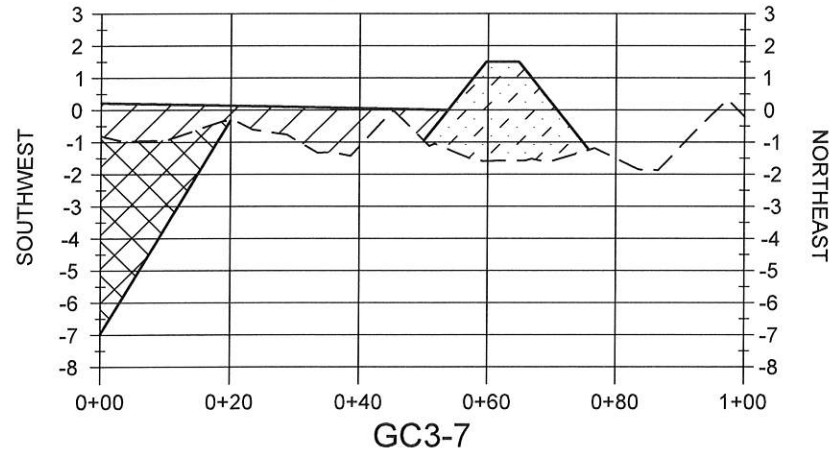
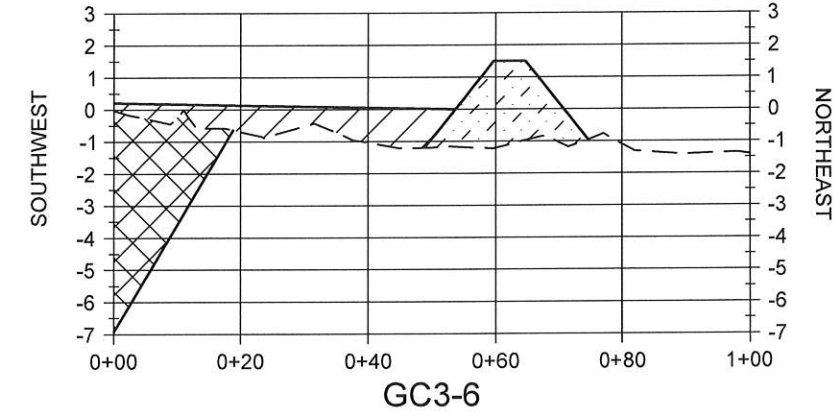
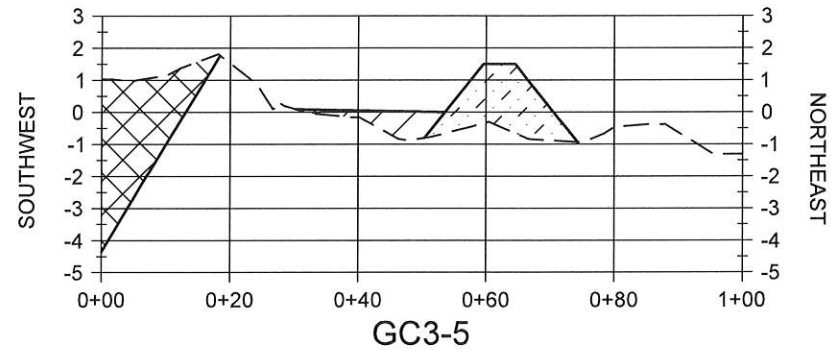
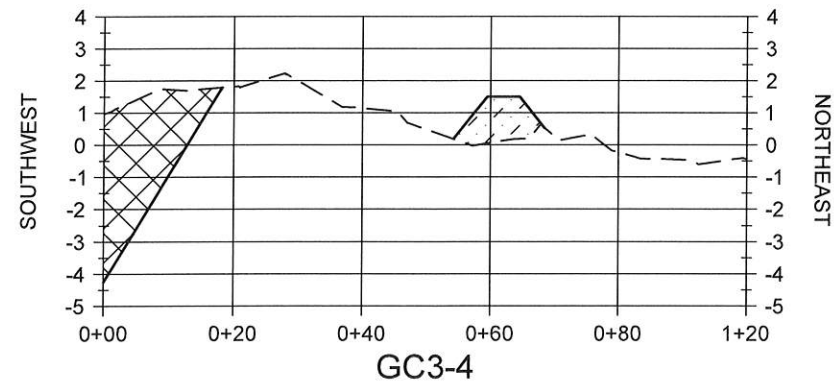
COASTAL PROTECTION AND RESTORATION AUTHORITY 150 TERRACE AVENUE BATON ROUGE, LOUISIANA 70802		REV.	DATE	BY
WEST MARSH CREATION AREA SECTIONS		DESIGNED BY: T. MCLAIN, E.I. APPROVED BY: T. FITZGERALD, P.E. P.E. NO. 38153		
NORTHWEST TURTLE BAY MARSH CREATION PROJECT		STATE PROJECT NUMBER: BA-0125 DRAWN BY: K. CANTU		
DATE: DEC. 2018		SHEET 48 OF 79		



NOTE:
ALL ELEVATIONS ARE GIVEN IN THE NORTH
AMERICAN VERTICAL DATUM OF 1988
(NAVD88) GEOID 12A.

LEGEND	
	EARTHEN GAP CLOSURE
	EARTHEN GAP CLOSURE BORROW AREA
	MARSH CREATION FILL
	EXISTING GRADE

COASTAL PROTECTION AND RESTORATION AUTHORITY 150 TERRACE AVENUE BATON ROUGE, LOUISIANA 70802		DATE	BY
WEST MARSH CREATION AREA SECTIONS		REV.	DESCRIPTION
NORTHWEST TURTLE BAY MARSH CREATION PROJECT		DATE	BY
STATE PROJECT NUMBER: BA-0125	DESIGNED BY: T. MCLAIN, E.I.	DATE	BY
DRAWN BY: K. CANTU	APPROVED BY: T. FITZGERALD, P.E.	DATE	BY
DATE: DEC. 2018		P.E. NO. 38153	
SHEET 49 OF 79			

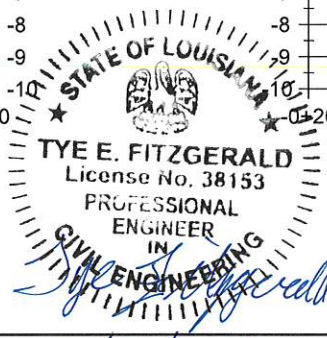
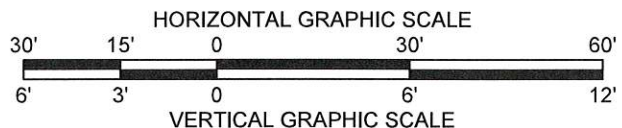
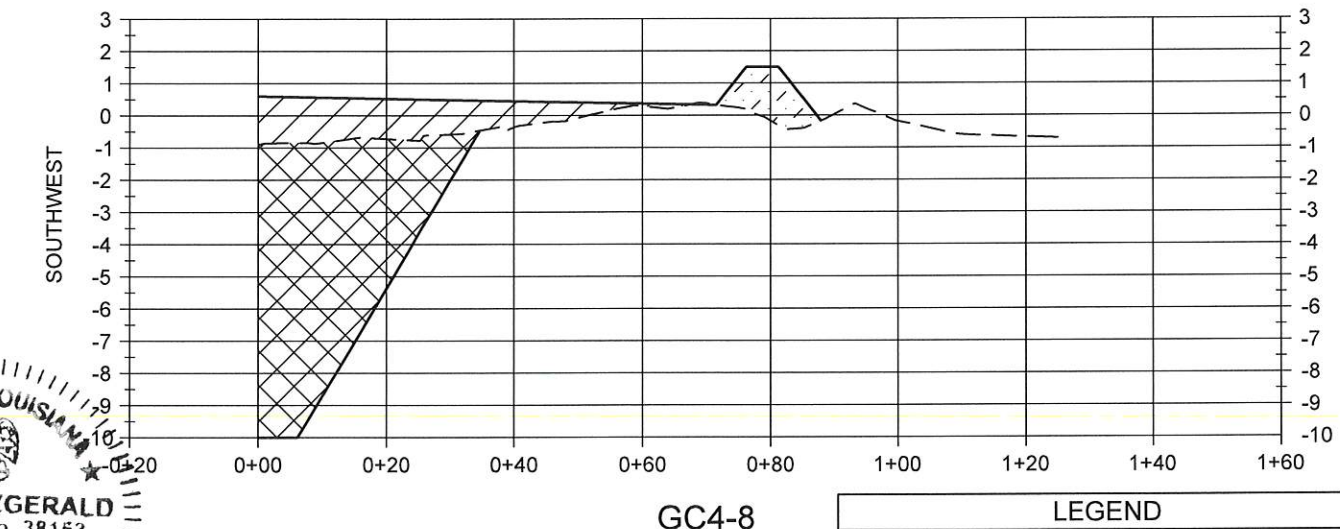
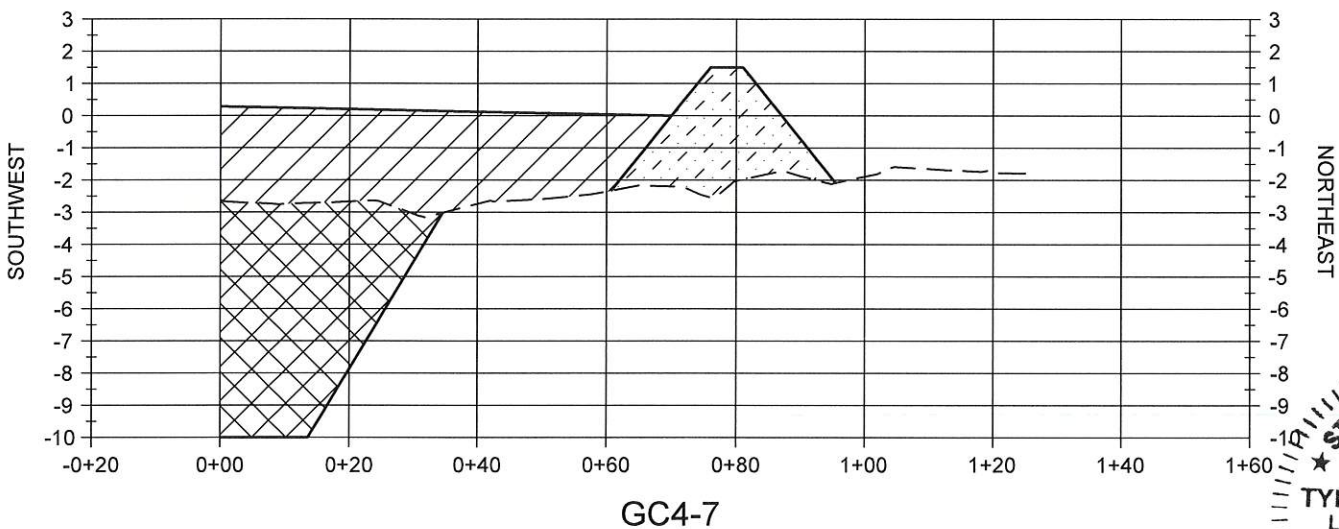
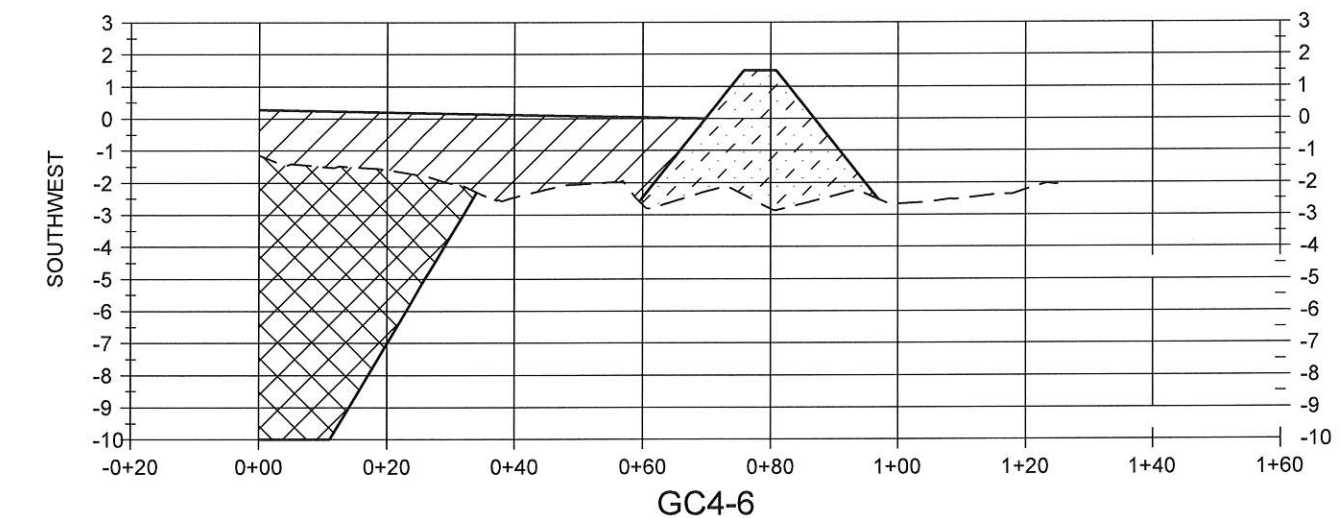
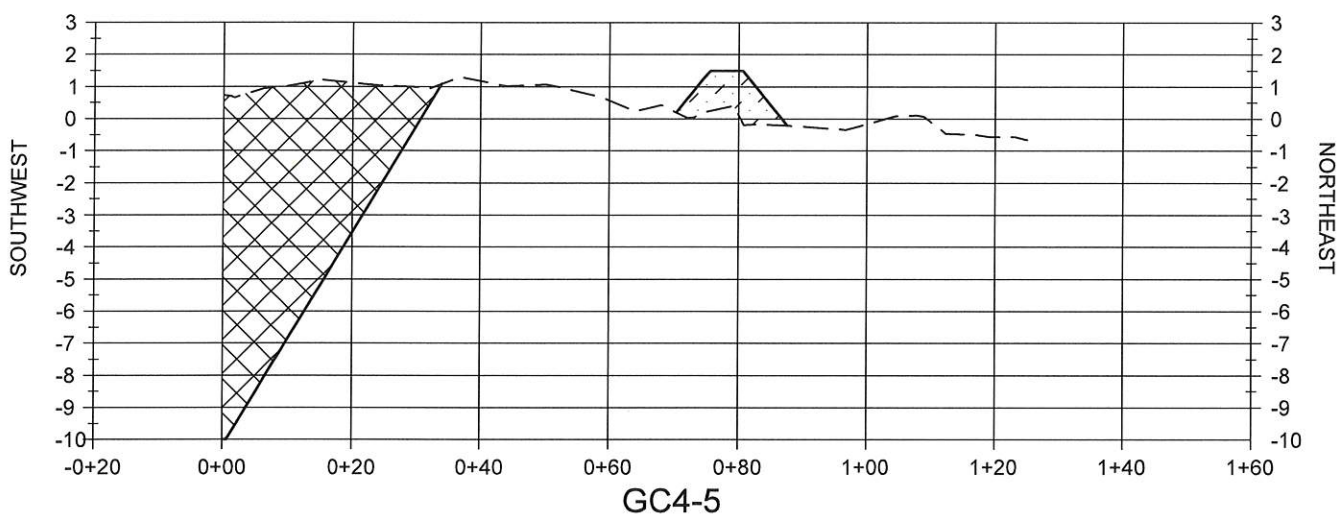
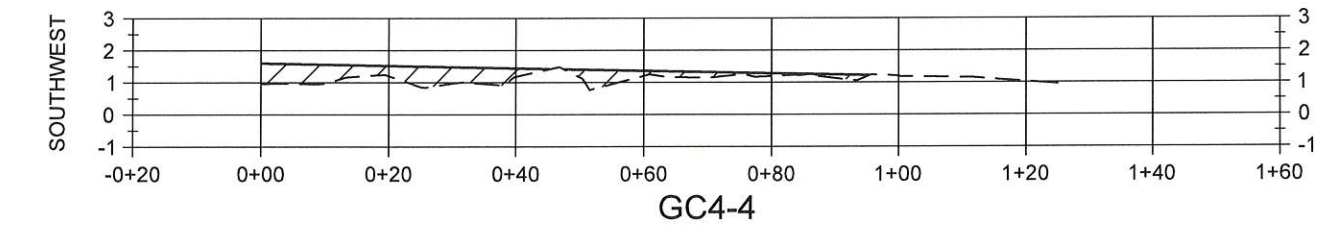
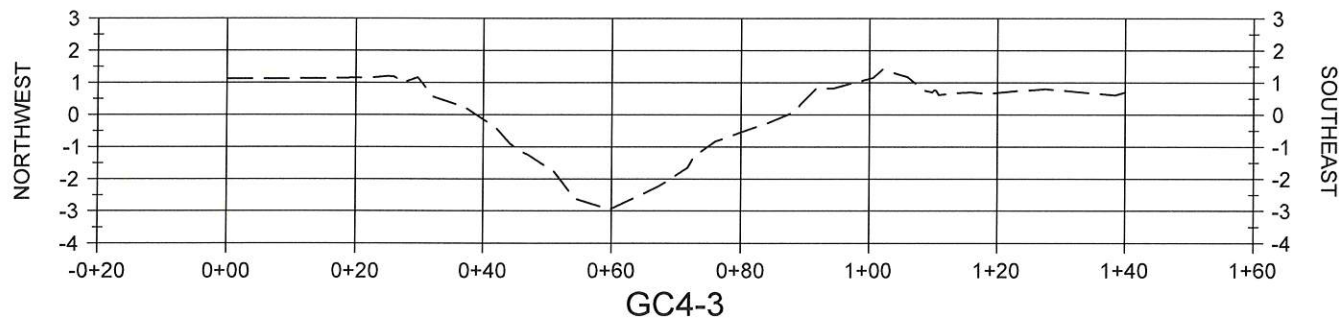
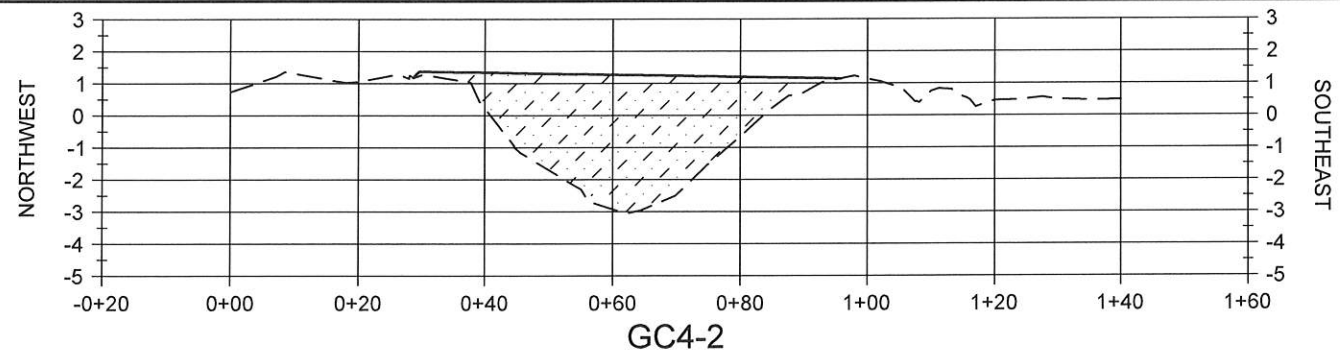
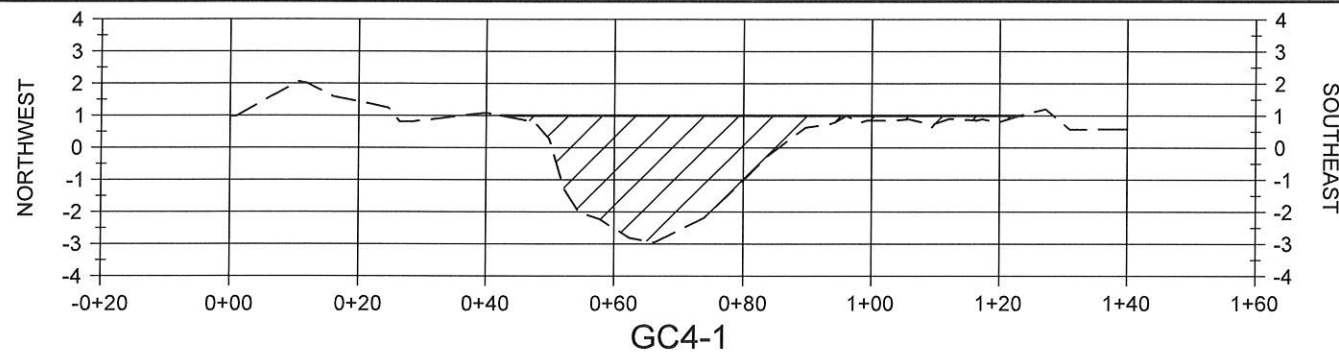

12/12/2010

NOTE:
ALL ELEVATIONS ARE GIVEN IN THE NORTH AMERICAN
VERTICAL DATUM OF 1988 (NAVD88) GEOID 12A.

LEGEND	
	EARTHEN GAP CLOSURE
	EARTHEN GAP CLOSURE BORROW AREA
	MARSH CREATION FILL
	EXISTING GRADE

COASTAL PROTECTION AND RESTORATION AUTHORITY 150 TERRACE AVENUE BATON ROUGE, LOUISIANA 70802		DATE	DESCRIPTION	BY
WEST MARSH CREATION AREA SECTIONS		DESIGNED BY: T. MCLAIN, E.I.	APPROVED BY: T. FITZGERALD, P.E.	P. E. NO. 38153
NORTHWEST TURTLE BAY MARSH CREATION PROJECT		STATE PROJECT NUMBER: BA-0125	DRAWN BY: K. CANTU	
DATE: DEC. 2018		SHEET 50 OF 79		

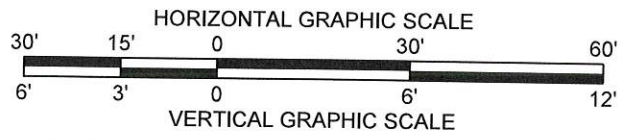
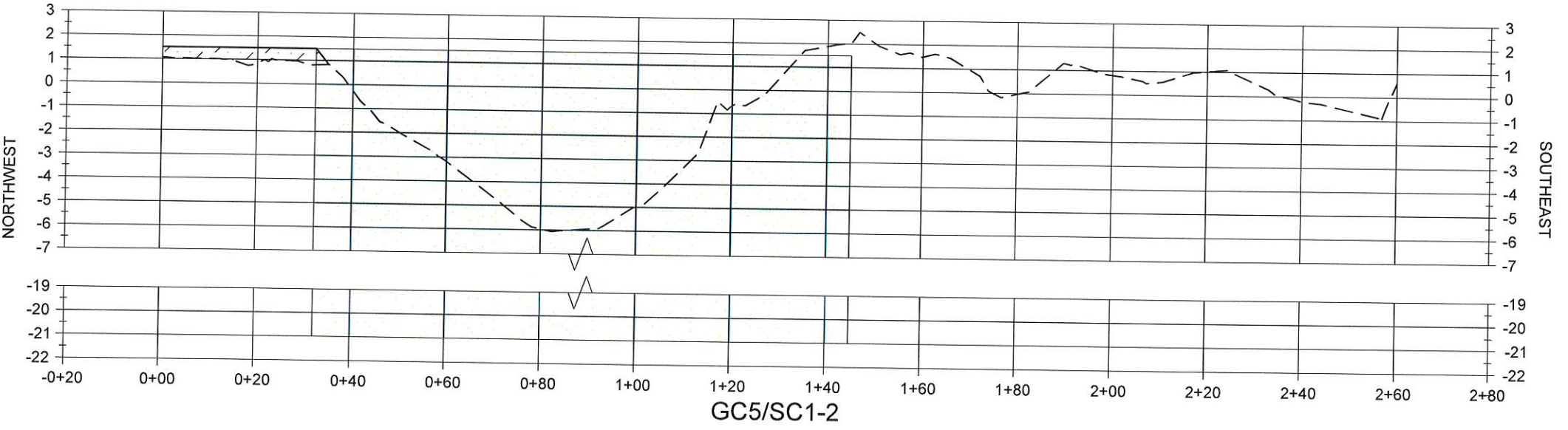
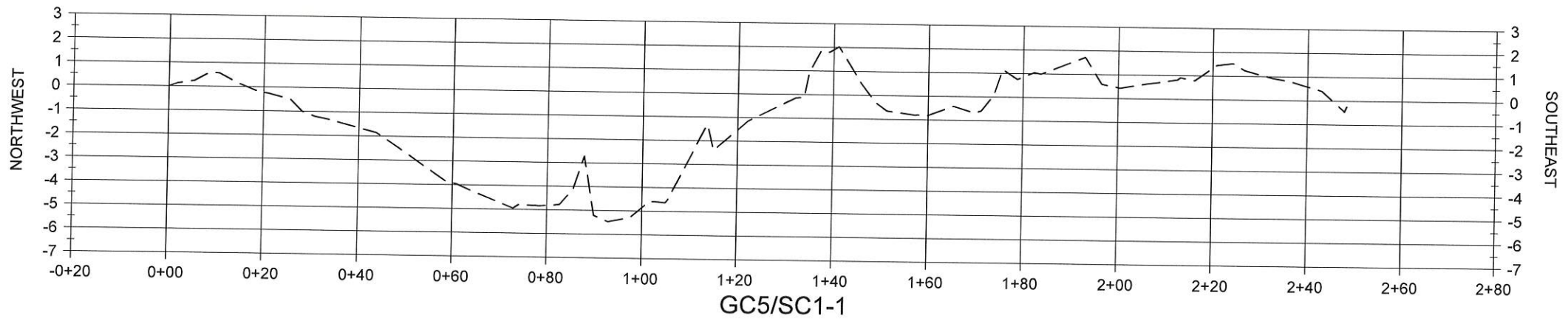
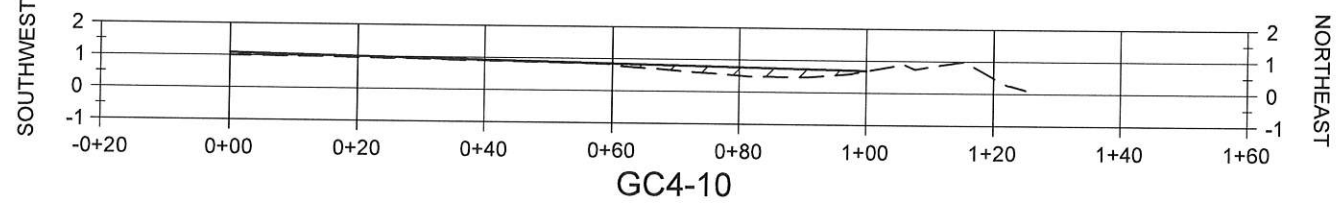
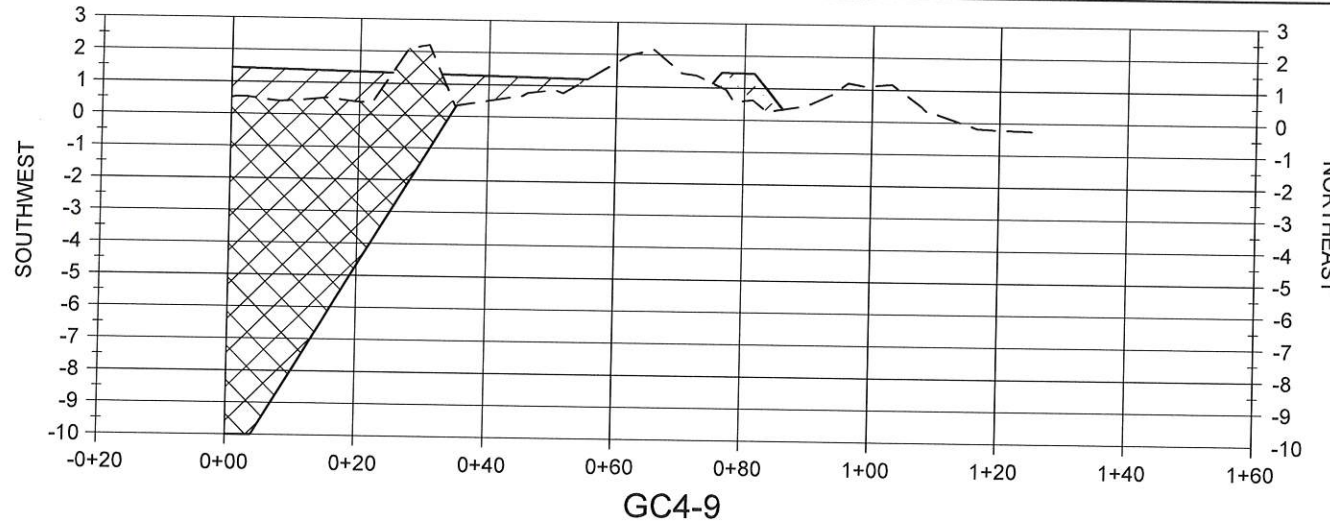

NOTE:
ALL ELEVATIONS ARE GIVEN IN THE NORTH AMERICAN
VERTICAL DATUM OF 1988 (NAVD88) GEOID 12A.

LEGEND	
	EARTHEN GAP CLOSURE
	EARTHEN GAP CLOSURE BORROW AREA
	MARSH CREATION FILL
	SHEET PILE
	EXISTING GRADE



COASTAL PROTECTION AND RESTORATION AUTHORITY 150 TERRACE AVENUE BATON ROUGE, LOUISIANA 70802	
WEST MARSH CREATION AREA SECTIONS	DESIGNED BY: T. MCLAIN, E.I. APPROVED BY: T. FITZGERALD, P.E. P.E. NO. 38153
NORTHWEST TURTLE BAY MARSH CREATION PROJECT	STATE PROJECT NUMBER: BA-0125 DRAWN BY: K. CANTU
DATE: DEC. 2018	
SHEET 51 OF 79	

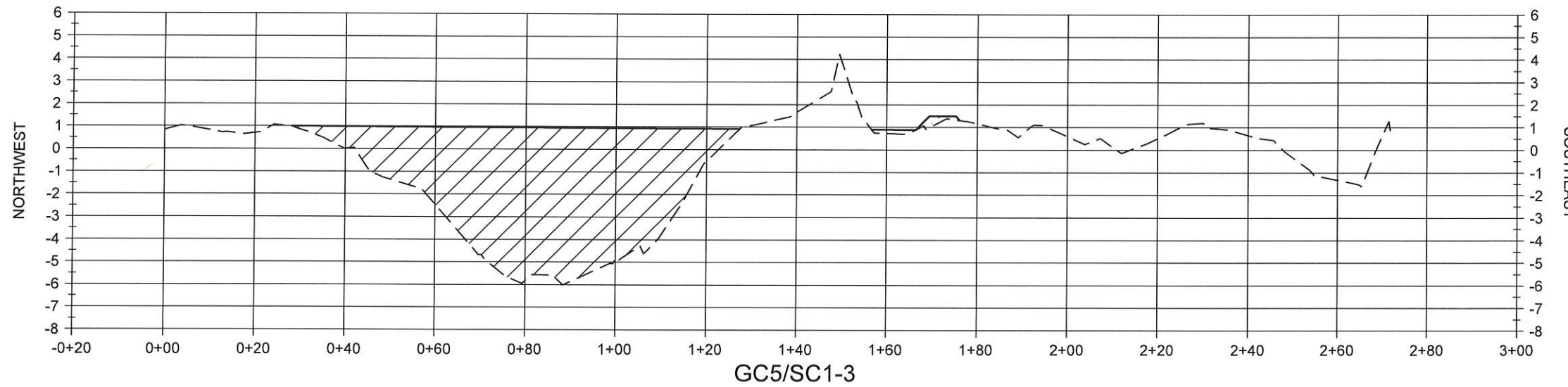

STATE OF LOUISIANA
 TYE E. FITZGERALD
 License No. 38153
 PROFESSIONAL
 ENGINEER
 IN
 CIVIL ENGINEERING
T. Fitzgerald
 12/12/2018

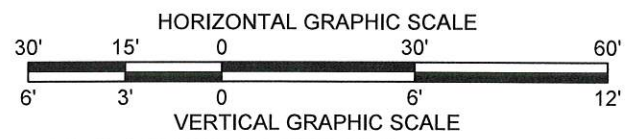
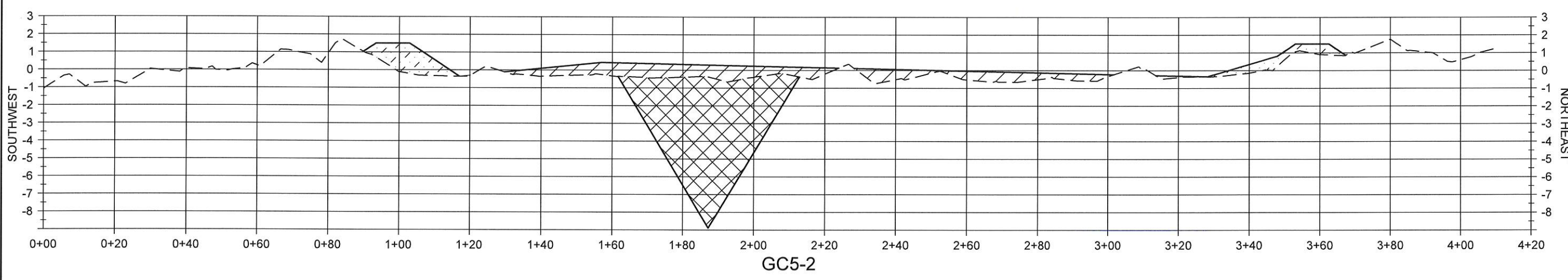
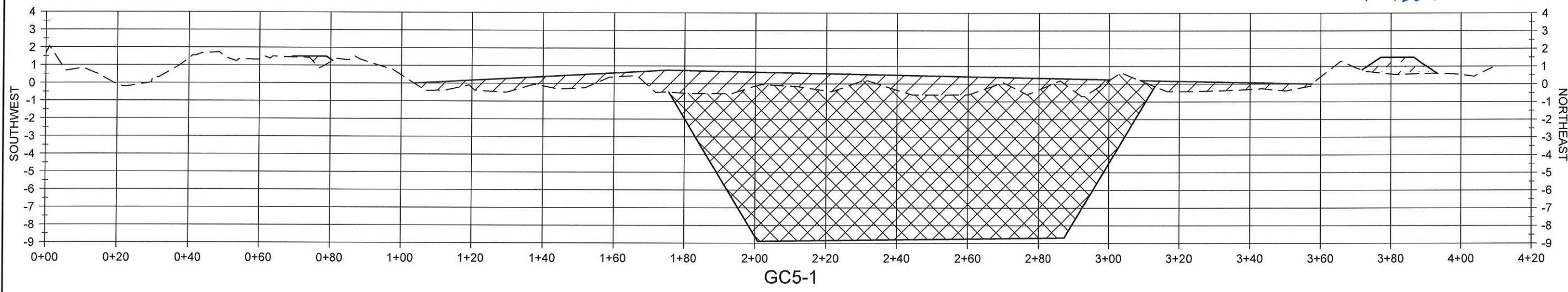

NOTE:
 ALL ELEVATIONS ARE GIVEN IN THE NORTH AMERICAN
 VERTICAL DATUM OF 1988 (NAVD88) GEOID 12A.

LEGEND	
	EARTHEN GAP CLOSURE
	EARTHEN GAP CLOSURE BORROW AREA
	MARSH CREATION FILL
	EXISTING GRADE

COASTAL PROTECTION AND RESTORATION AUTHORITY 150 TERRACE AVENUE BATON ROUGE, LOUISIANA 70802		DATE	DESCRIPTION	BY
WEST MARSH CREATION AREA SECTIONS		REV.		
NORTHWEST TURTLE BAY MARSH CREATION PROJECT	DESIGNED BY: T. MCLAIN, E.I.			
STATE PROJECT NUMBER: BA-0125	APPROVED BY: T. FITZGERALD, P.E. P.E. NO. 38153			
DRAWN BY: K. CANTU				
DATE: DEC 2018				
SHEET 52 OF 79				

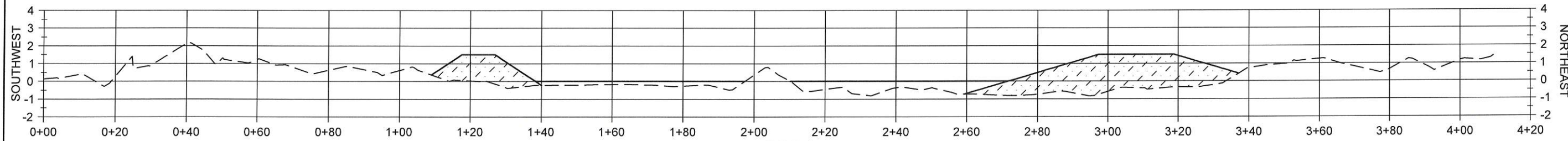

GC5-3

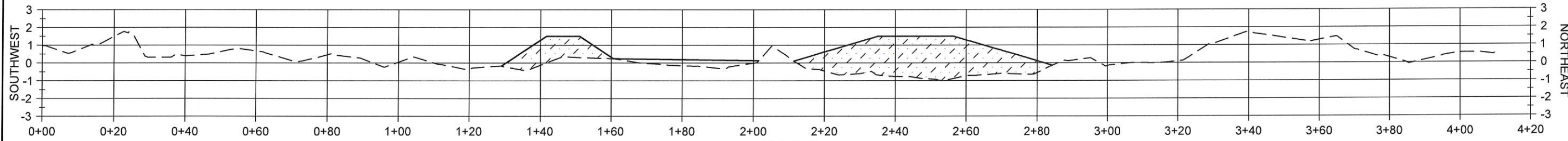

GC5-4

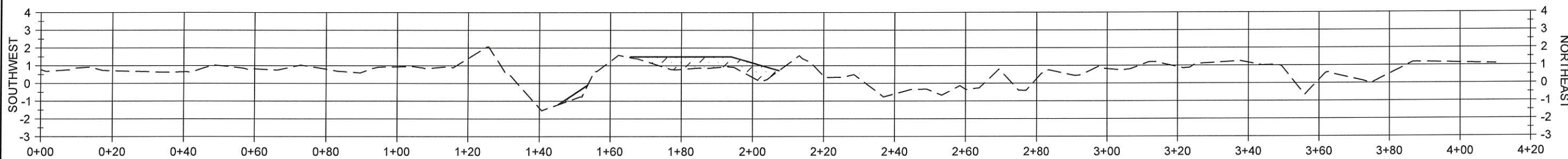

GC5-5

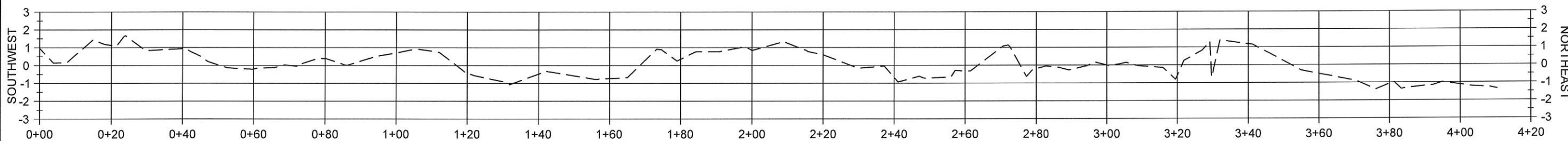

GC5-6

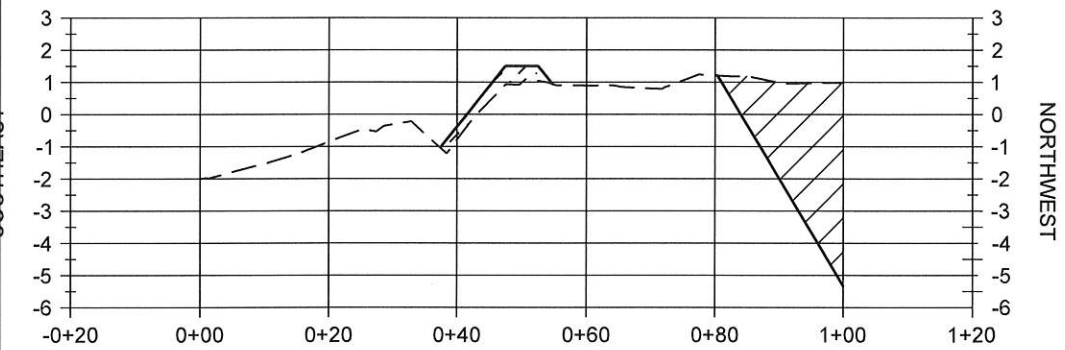

SC-1

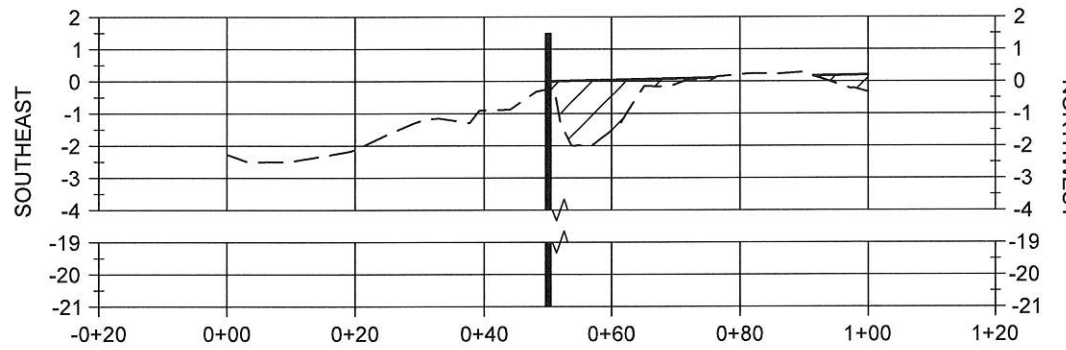

SC-2

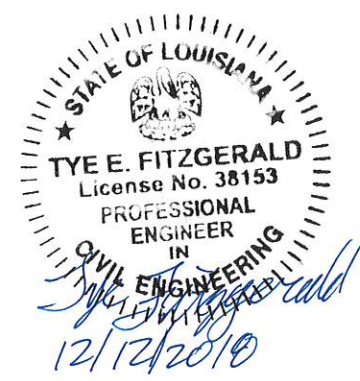

LEGEND	
	EARTHEN GAP CLOSURE
	EARTHEN GAP CLOSURE BORROW AREA
	MARSH CREATION FILL
	EXISTING GRADE
	SHEET PILE

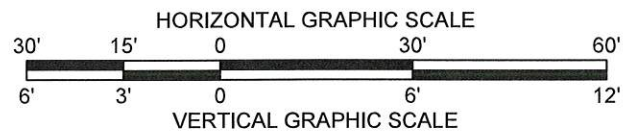

NOTE:
ALL ELEVATIONS ARE GIVEN IN THE NORTH AMERICAN
VERTICAL DATUM OF 1988 (NAVD88) GEOID 12A.

COASTAL PROTECTION AND RESTORATION AUTHORITY 150 TERRACE AVENUE BATON ROUGE, LOUISIANA 70802		DESIGNED BY: T. MCCLAIN, E.I.	APPROVED BY: T. FITZGERALD, P.E. P.E. NO. 38153
WEST MARSH CREATION AREA SECTIONS		STATE PROJECT NUMBER: BA-0125	DRAWN BY: K. CANTU
NORTHWEST TURTLE BAY MARSH CREATION PROJECT		DATE: DEC. 2018	SHEET 53 OF 79
BY	DESCRIPTION	DATE	REV.

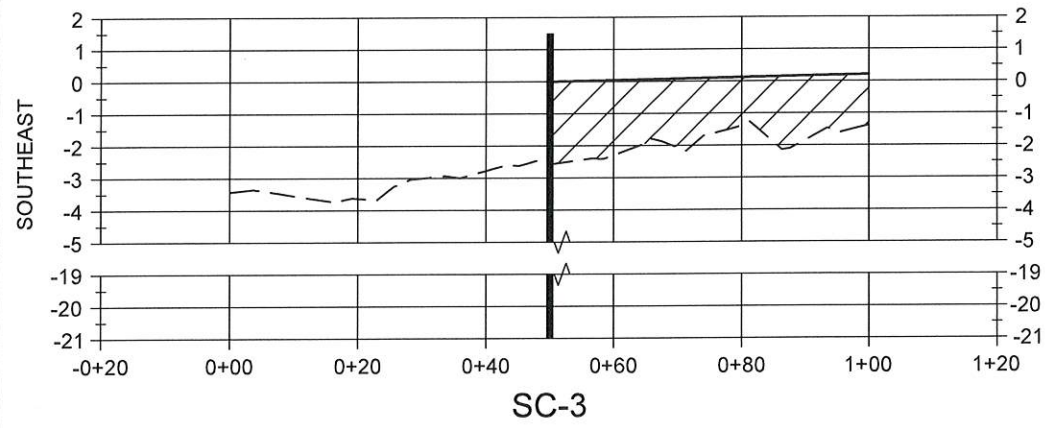

SC-3

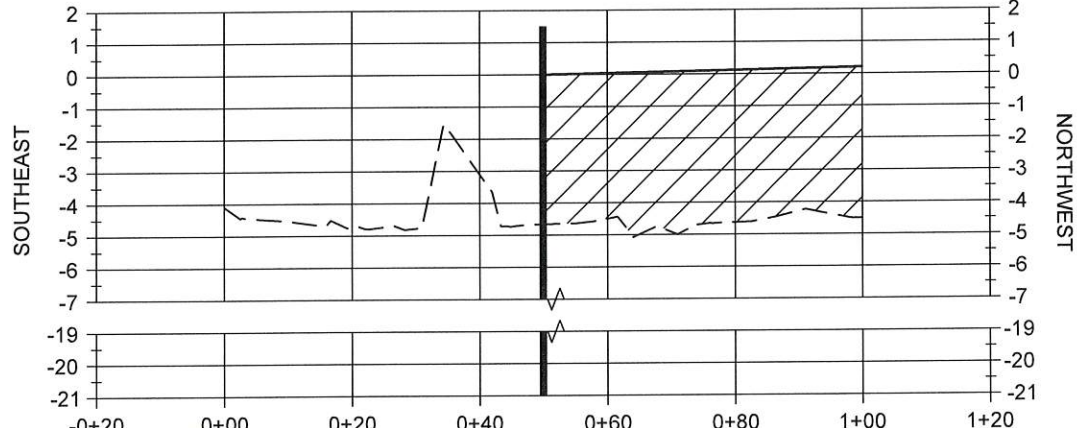

SC-4

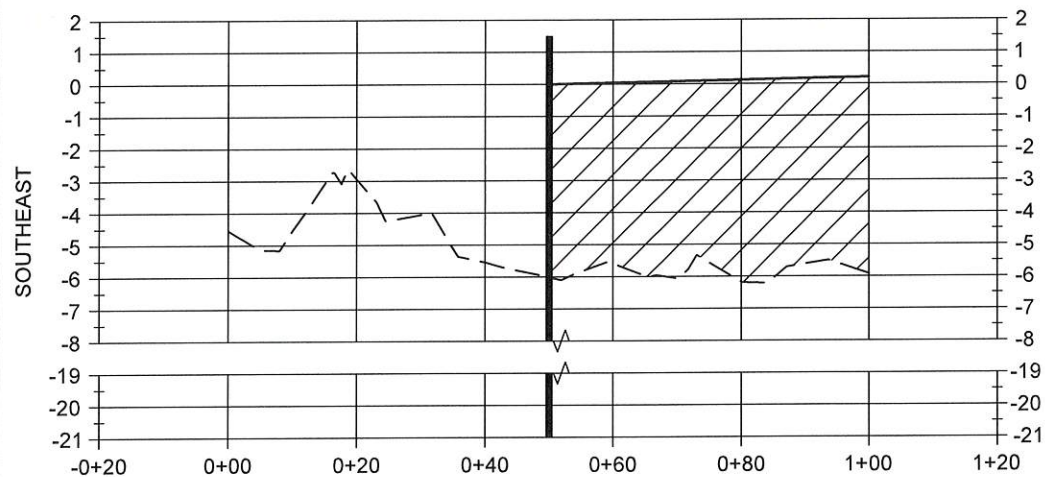

SC-5

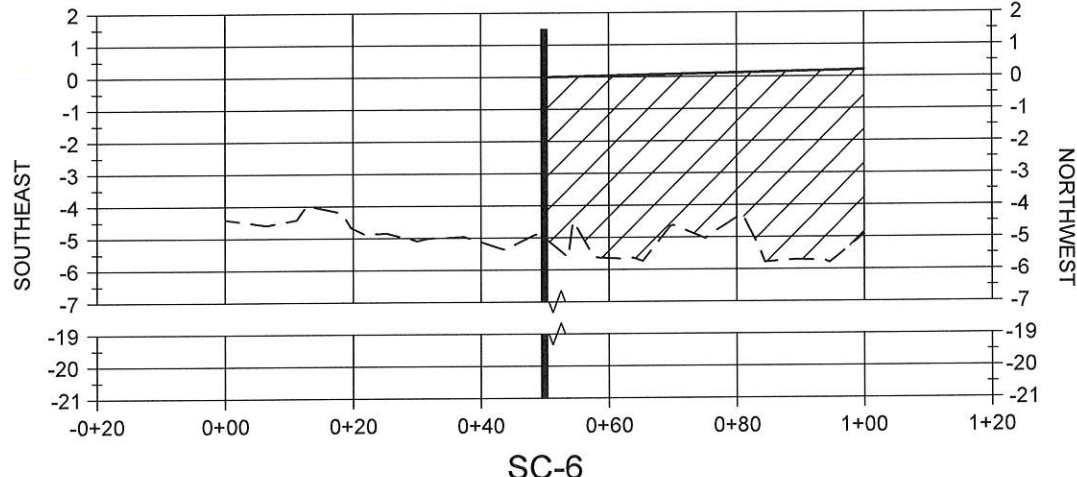

SC-6

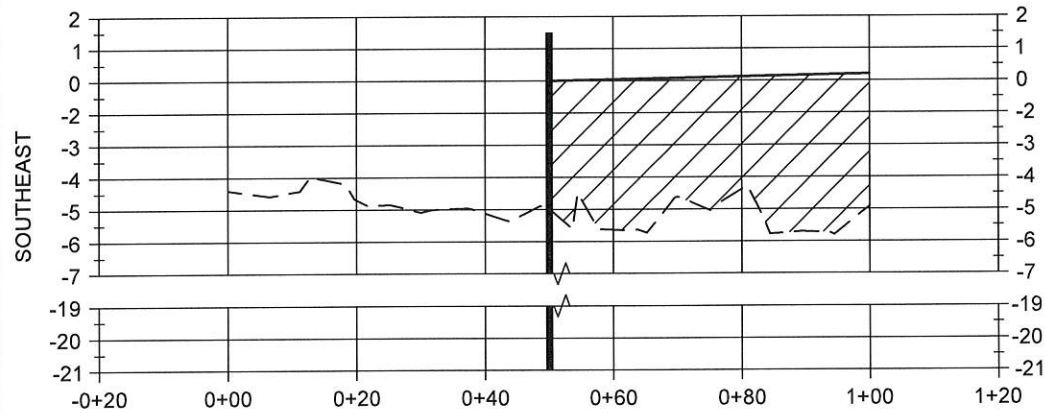

SC-6

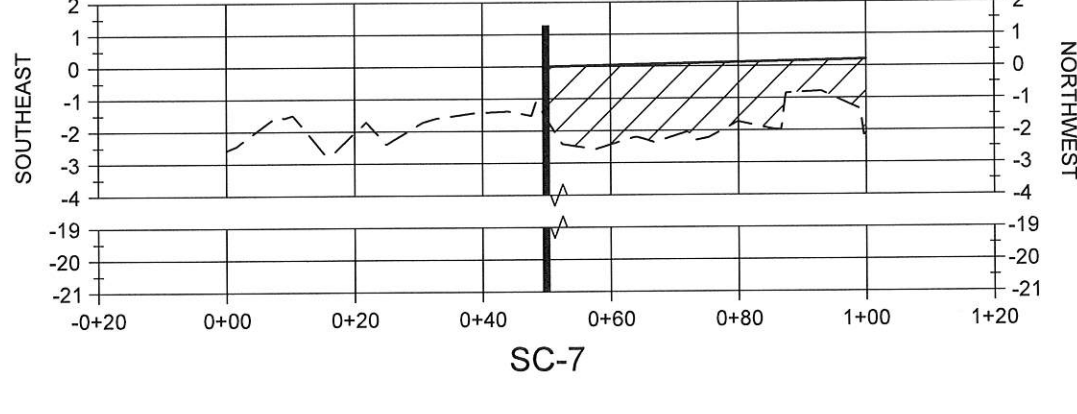

SC-7

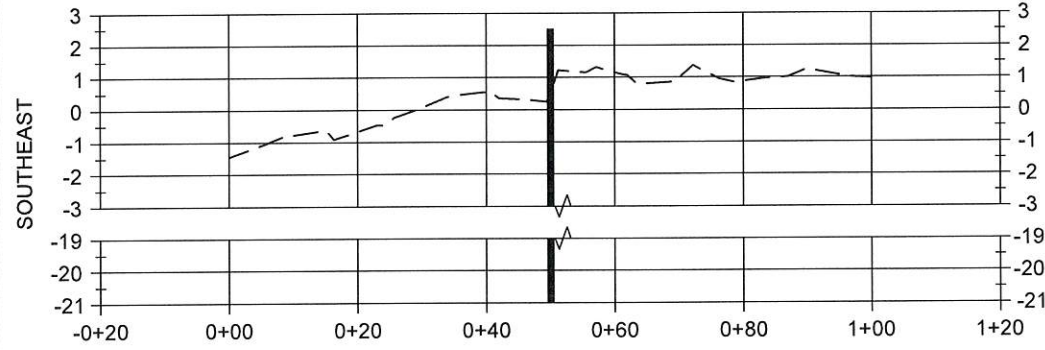

SC-8

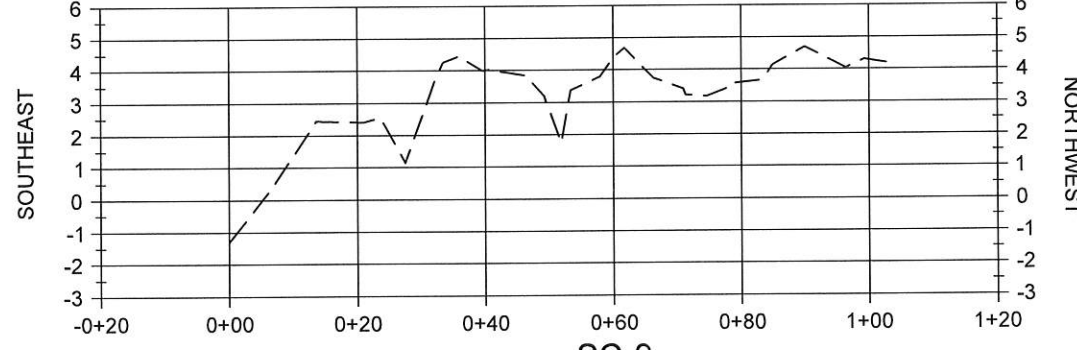

SC-9

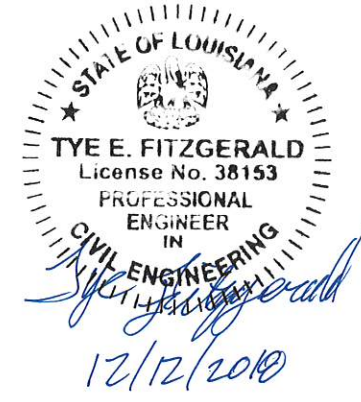

LEGEND	
	MARSH CREATION FILL
	EXISTING GRADE
	SHEET PILE

NOTE:
ALL ELEVATIONS ARE GIVEN IN THE
NORTH AMERICAN VERTICAL DATUM
OF 1988 (NAVD88) GEOID 12A.

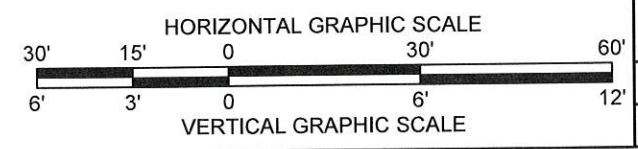

COASTAL PROTECTION AND RESTORATION AUTHORITY 150 TERRACE AVENUE BATON ROUGE, LOUISIANA 70802		DESIGNED BY: T. MCLAIN, E.I.	APPROVED BY: T. FITZGERALD, P.E.	P.E. NO. 38153
		STATE PROJECT NUMBER: BA-0125	DRAWN BY: K. CANTU	
WEST MARSH CREATION AREA SECTIONS		NORTHWEST TURTLE BAY MARSH CREATION PROJECT		
DATE	REV.	DESCRIPTION	DATE	BY
DEC. 2018				
SHEET 54 OF 79				

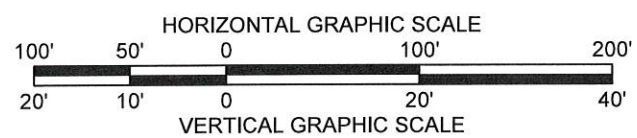
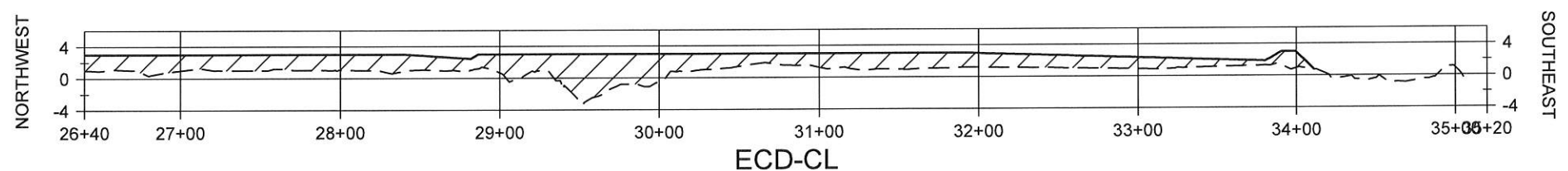
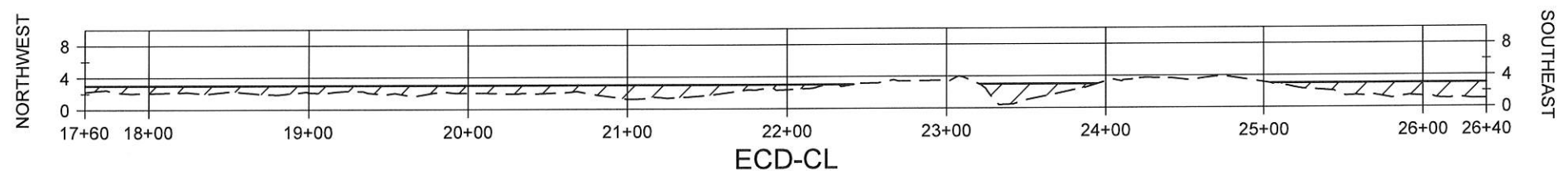
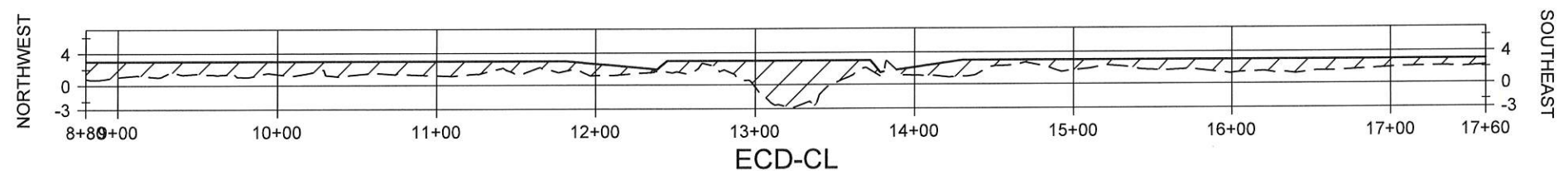
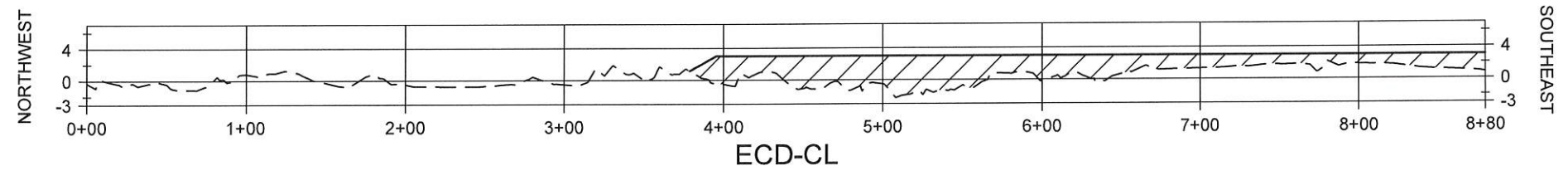

NOTE:
ALL ELEVATIONS ARE GIVEN IN THE NORTH AMERICAN
VERTICAL DATUM OF 1988 (NAVD88) GEOID 12A.

LEGEND	
	MARSH CREATION FILL
	EXISTING GRADE



COASTAL PROTECTION AND RESTORATION AUTHORITY 150 TERRACE AVENUE BATON ROUGE, LOUISIANA 70802		DATE	REV.	DESCRIPTION	BY
WEST MARSH CREATION AREA SECTIONS		DESIGNED BY: T. MCLAIN, E.I.	APPROVED BY: T. FITZGERALD, P.E.	P. E. NO. 38153	
NORTHWEST TURTLE BAY MARSH CREATION PROJECT		STATE PROJECT NUMBER: BA-0125	DRAWN BY: K. CANTU		
		DATE: DEC. 2018			
		SHEET 55 OF 79			

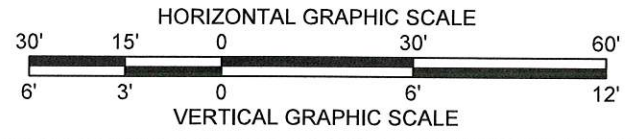
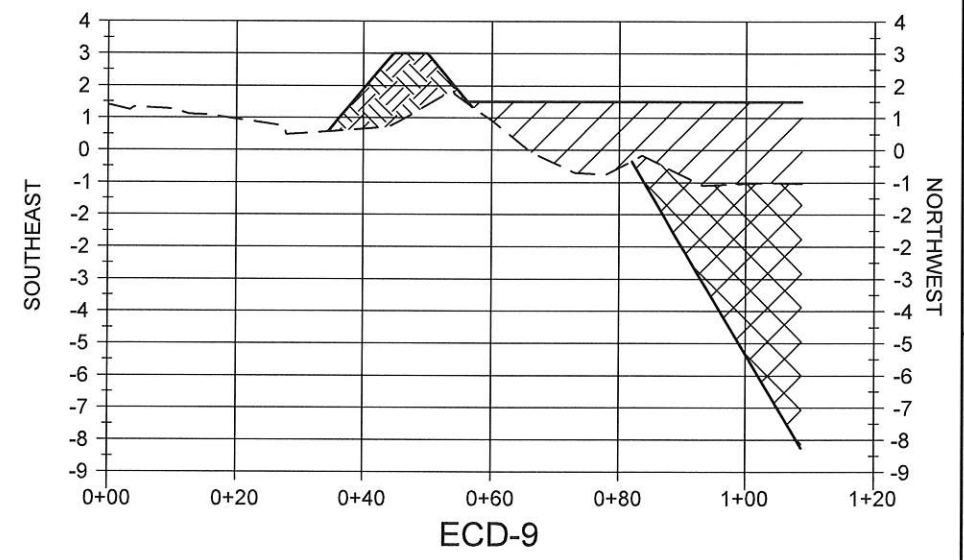
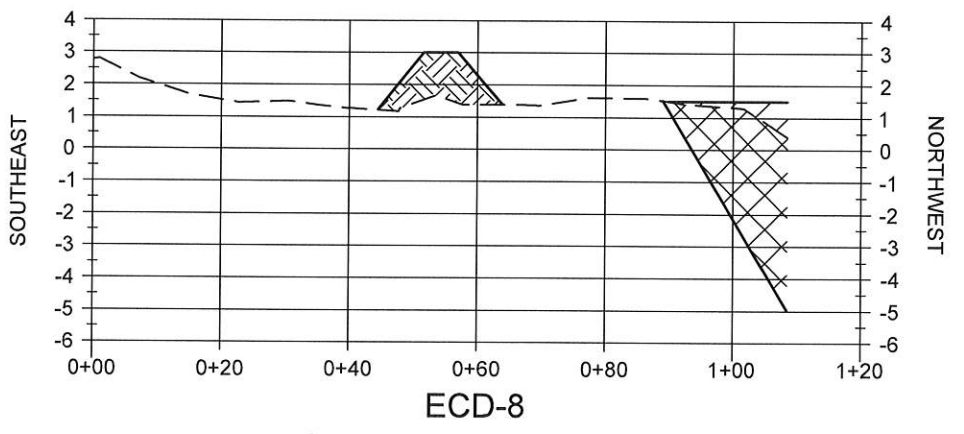
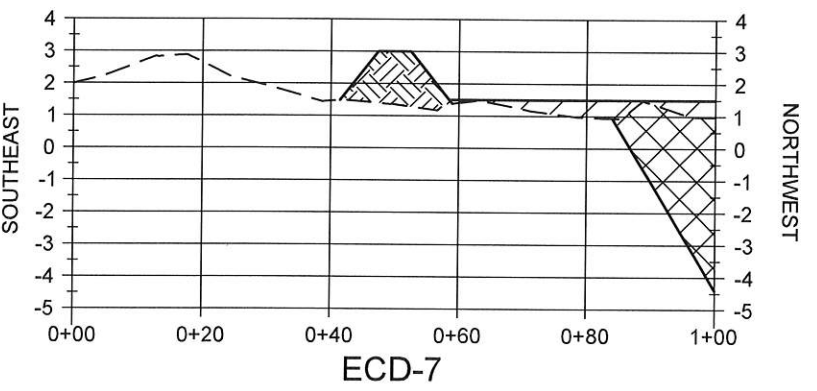
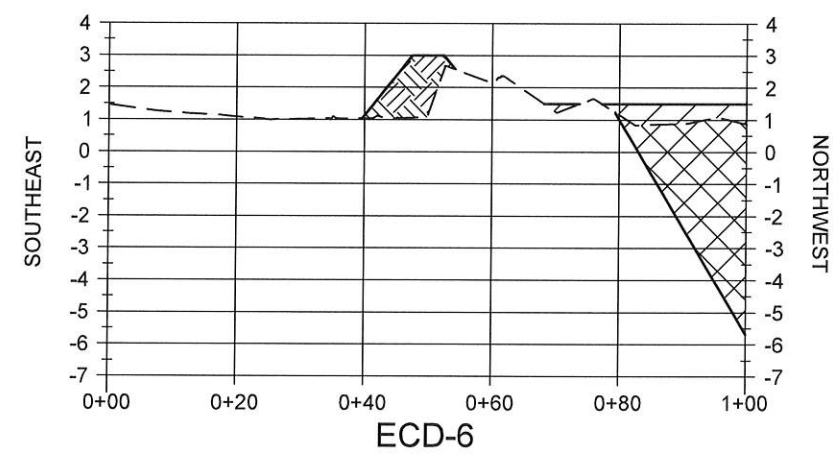
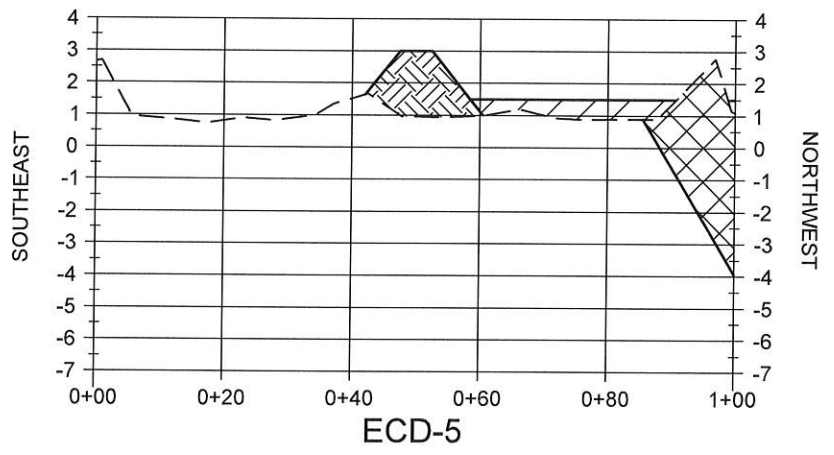
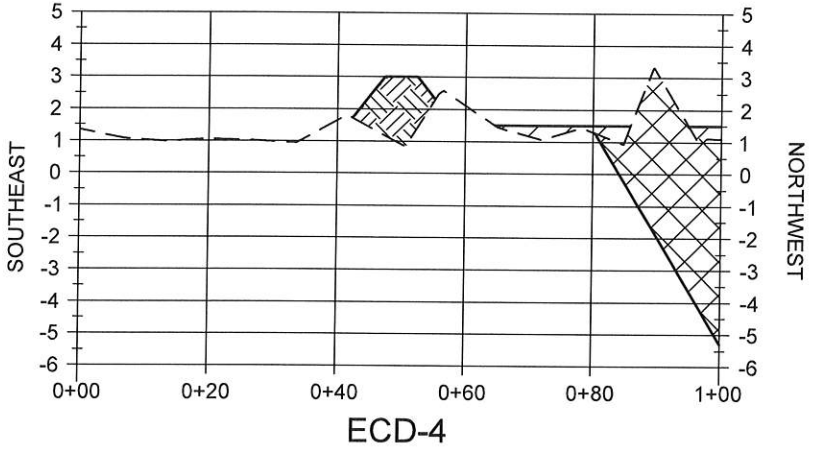
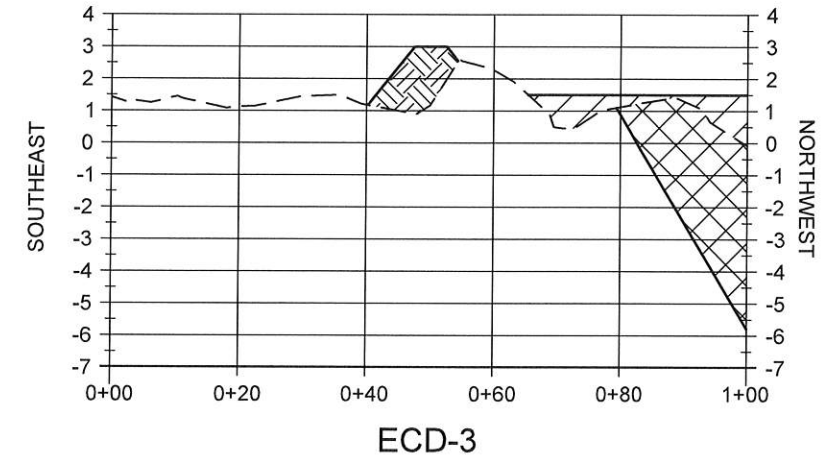
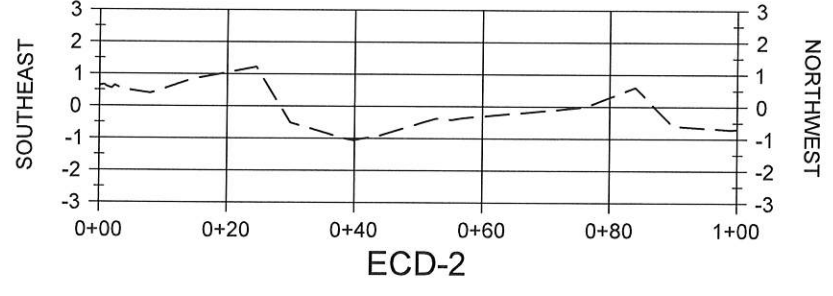
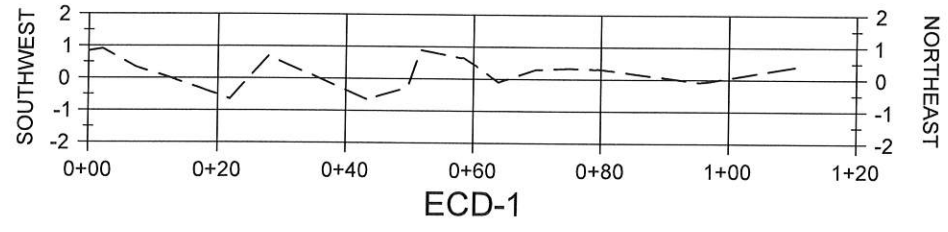

STATE OF LOUISIANA
 TYE E. FITZGERALD
 License No. 38153
 PROFESSIONAL ENGINEER
 IN
 CIVIL ENGINEERING
 12/12/2018

NOTE:
 ALL ELEVATIONS ARE GIVEN IN THE NORTH AMERICAN
 VERTICAL DATUM OF 1988 (NAVD88) GEOID 12A.

LEGEND	
	EARTHEN CONTAINMENT DIKE
	EARTHEN CONTAINMENT DIKE BORROW AREA
	MARSH CREATION FILL
	EXISTING GRADE

COASTAL PROTECTION AND RESTORATION AUTHORITY 150 TERRACE AVENUE BATON ROUGE, LOUISIANA 70802		DATE	BY
WEST MARSH CREATION AREA SECTIONS		REV.	DESCRIPTION
NORTHWEST TURTLE BAY MARSH CREATION PROJECT		DATE	BY
STATE PROJECT NUMBER: BA-0125	DESIGNED BY: T. MCLAIN, E.I.	DATE	BY
DRAWN BY: K. CANTU		DATE	BY
APPROVED BY: T. FITZGERALD, P.E. P.E. NO. 38153		DATE	BY
DATE: DEC. 2018		DATE	BY
SHEET 56 OF 79			

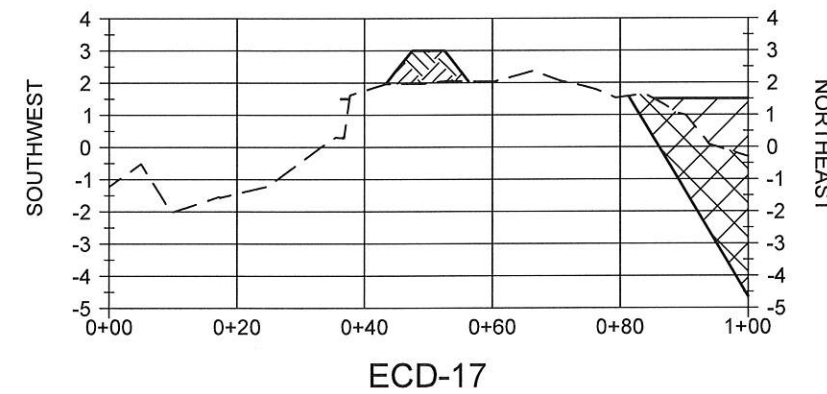
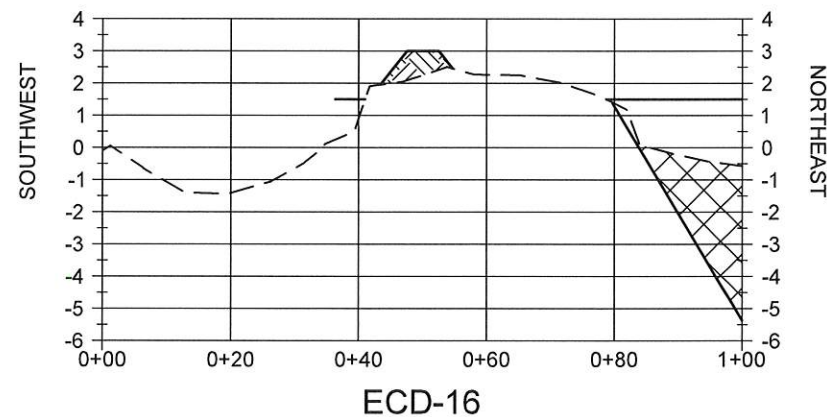
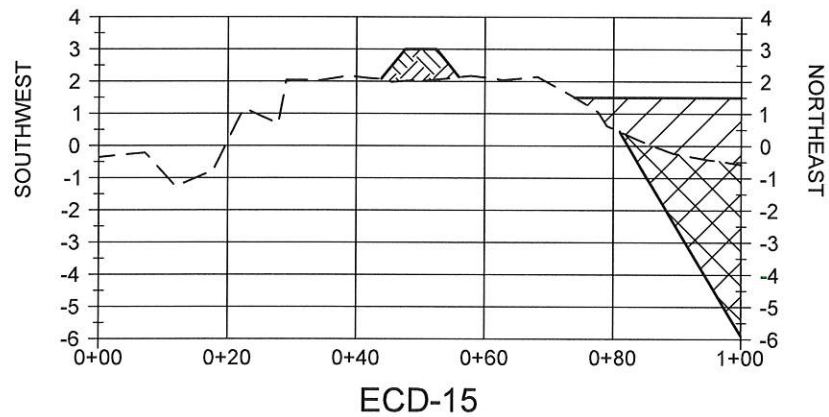
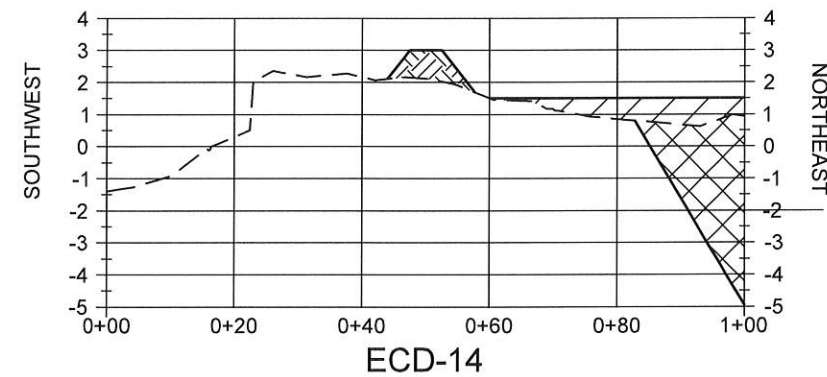
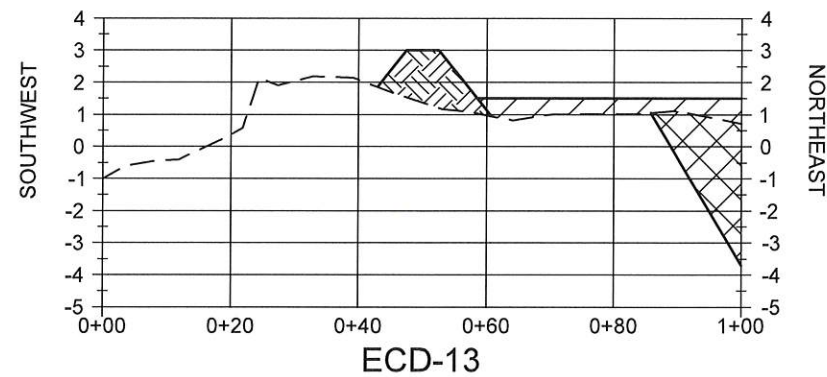
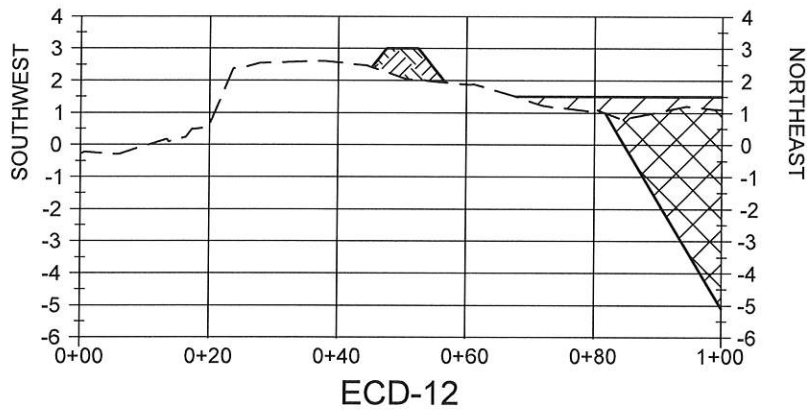
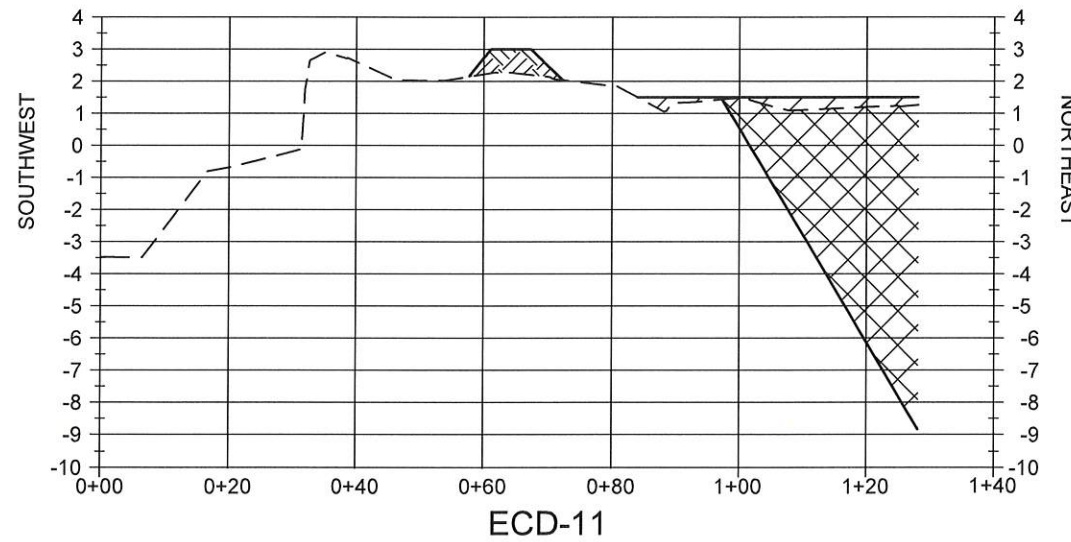
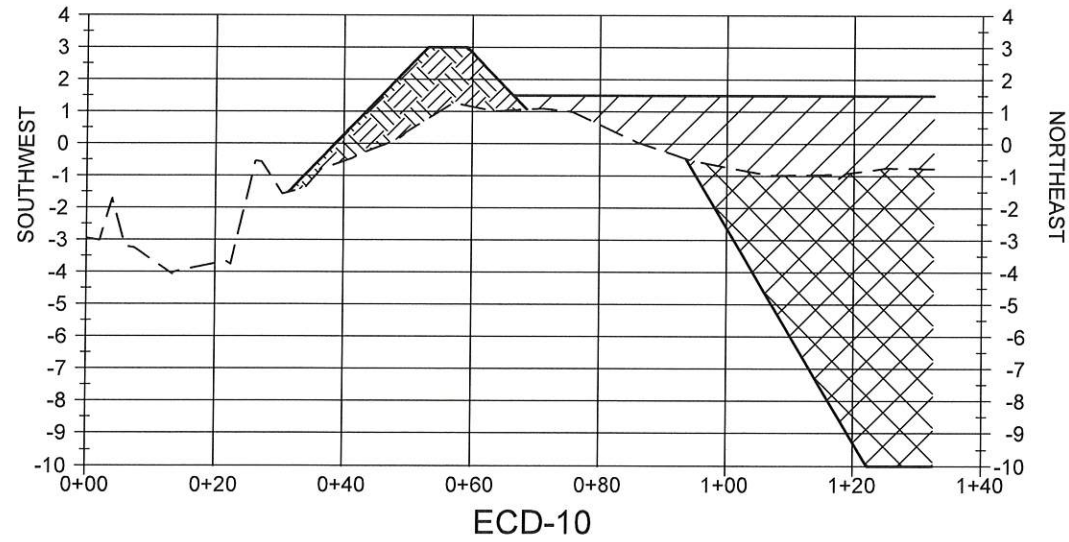

STATE OF LOUISIANA
 TYE E. FITZGERALD
 License No. 38153
 PROFESSIONAL ENGINEER
 IN
 CIVIL ENGINEERING
 12/12/2018

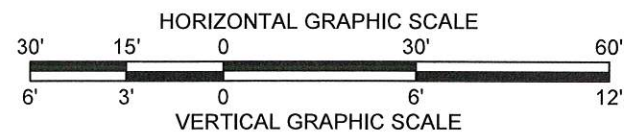

NOTE:
 ALL ELEVATIONS ARE GIVEN IN THE NORTH AMERICAN
 VERTICAL DATUM OF 1988 (NAVD88) GEOID 12A.

LEGEND	
	EARTHEN CONTAINMENT DIKE
	EARTHEN CONTAINMENT DIKE BORROW AREA
	MARSH CREATION FILL
	EXISTING GRADE

COASTAL PROTECTION AND RESTORATION AUTHORITY 150 TERRACE AVENUE BATON ROUGE, LOUISIANA 70802		DATE	DESCRIPTION	BY
WEST MARSH CREATION AREA SECTIONS		REV.		
NORTHWEST TURTLE BAY MARSH CREATION PROJECT				
STATE PROJECT NUMBER: BA-0125	DESIGNED BY: T. MCLAIN, E.I.			
DRAWN BY: K. CANTU	APPROVED BY: T. FITZGERALD, P.E. P.E. NO. 38153			
DATE: DEC. 2018				
SHEET 57 OF 79				

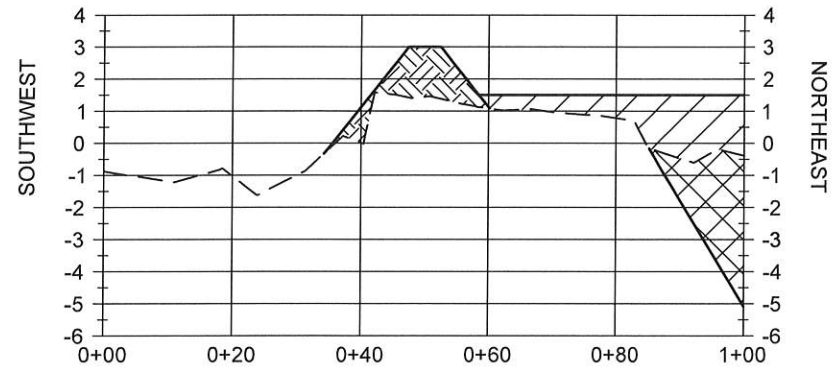

ECD-18

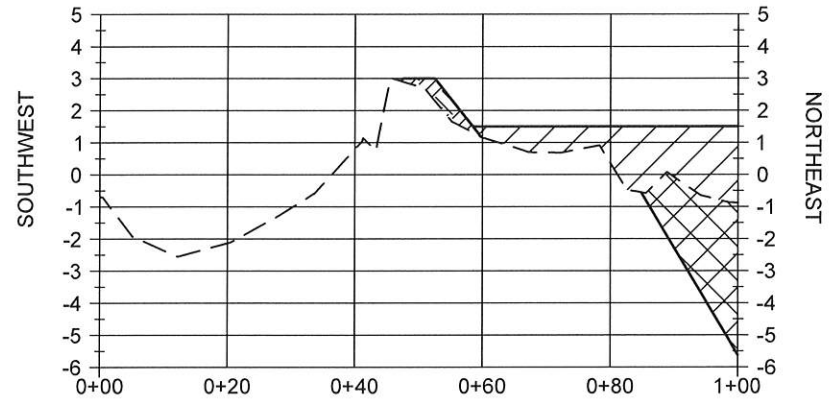

ECD-19

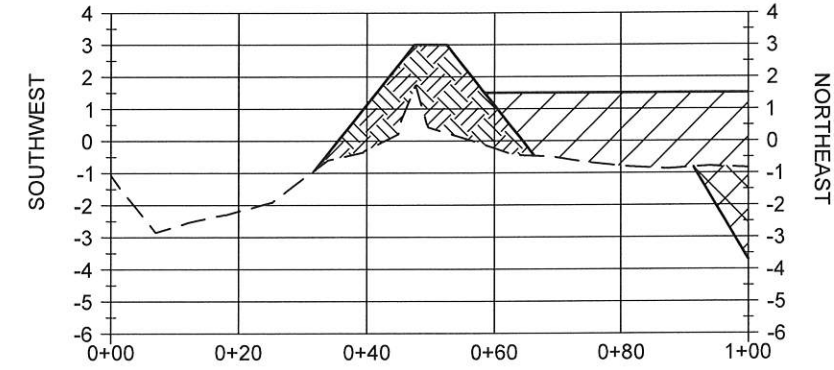

ECD-20

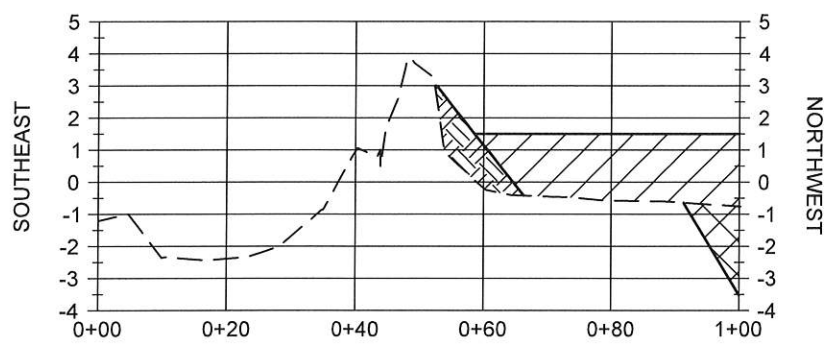

ECD-21

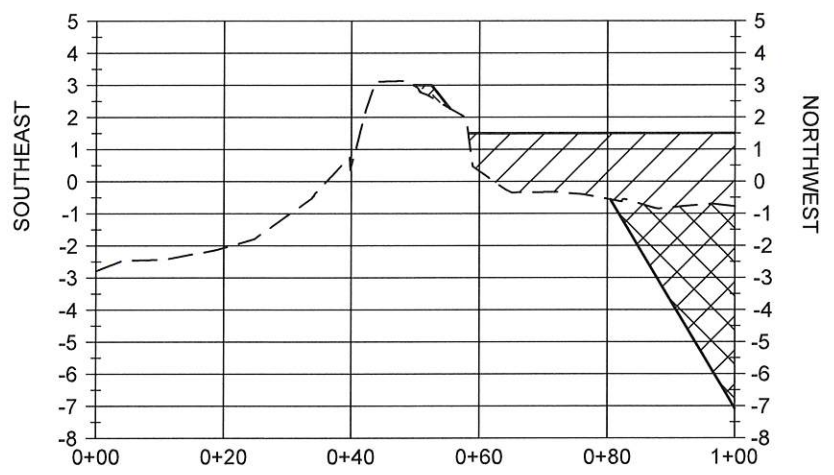

ECD-22

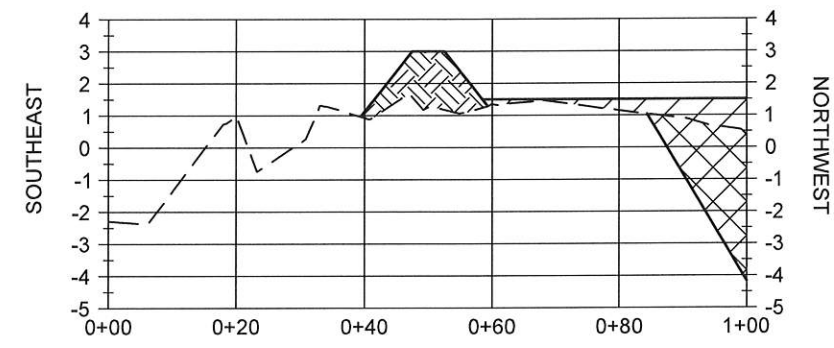

ECD-23

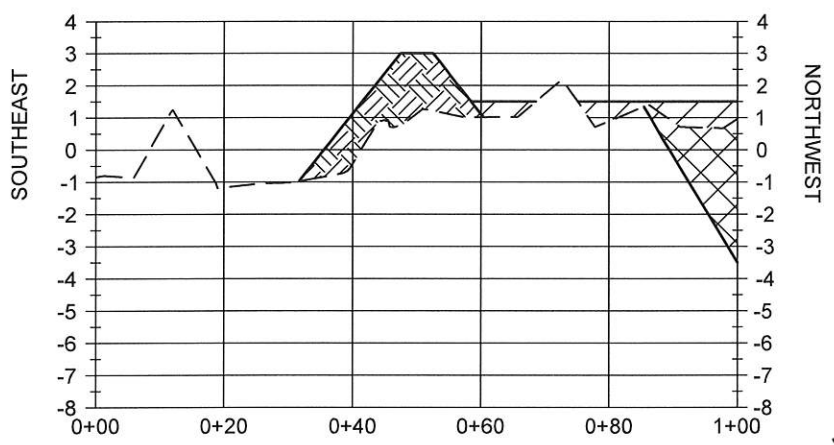

ECD-24

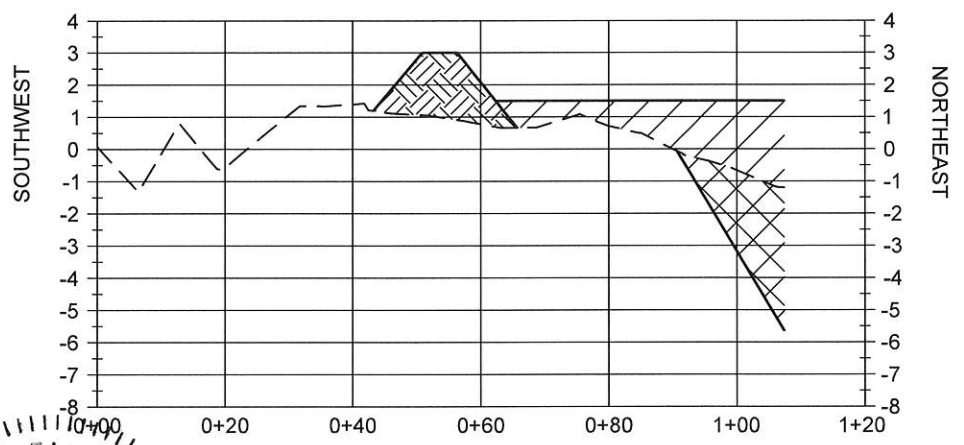

ECD-25

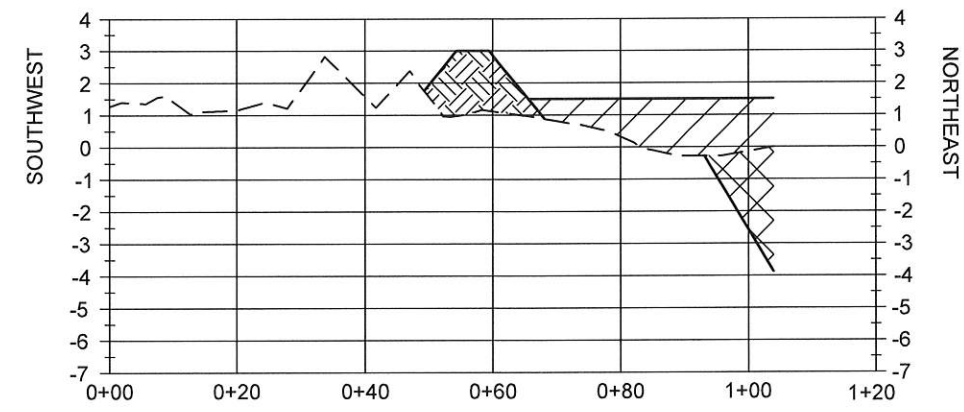

ECD-26

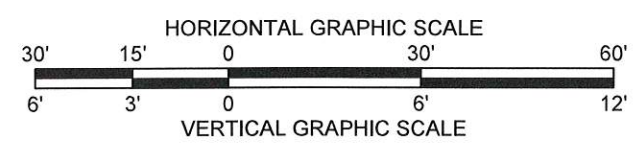

STATE OF LOUISIANA
 TYE E. FITZGERALD
 License No. 38153
 PROFESSIONAL ENGINEER
 CIVIL ENGINEERING

T. Fitzgerald

12/12/2010

NOTE:
 ALL ELEVATIONS ARE GIVEN IN THE NORTH AMERICAN
 VERTICAL DATUM OF 1988 (NAVD88) GEOID 12A.

LEGEND	
	EARTHEN CONTAINMENT DIKE
	EARTHEN CONTAINMENT DIKE BORROW AREA
	MARSH CREATION FILL
	EXISTING GRADE

COASTAL PROTECTION AND RESTORATION AUTHORITY 150 TERRACE AVENUE BATON ROUGE, LOUISIANA 70802		DATE	DESCRIPTION	BY
WEST MARSH CREATION AREA SECTIONS				
DESIGNED BY: T. MCCLAIN, E.I.				
APPROVED BY: T. FITZGERALD, P.E. P.E. NO. 38153				
NORTHWEST TURTLE BAY MARSH CREATION PROJECT				
STATE PROJECT NUMBER: BA-0125				
DRAWN BY: K. CANTU				
DATE: DEC. 2018				
SHEET 58 OF 79				

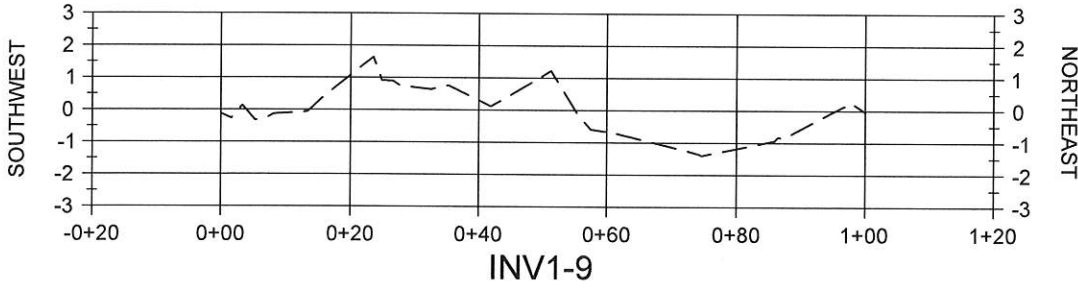
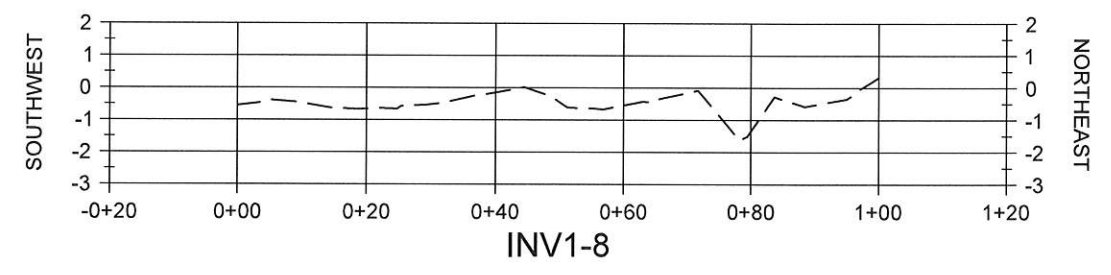
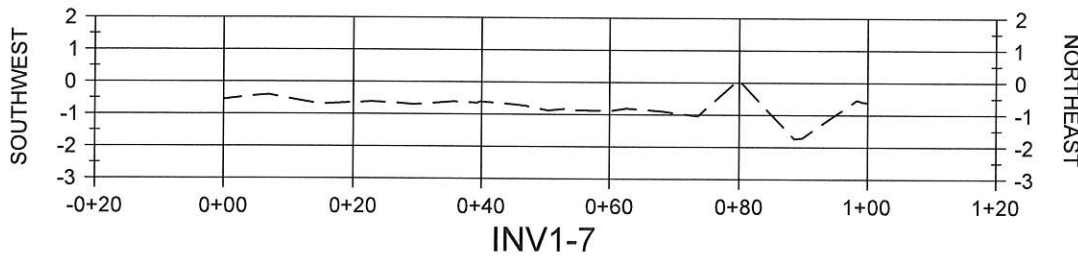
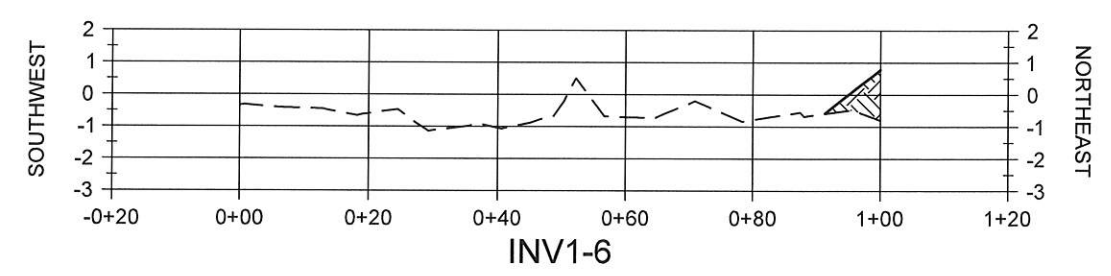
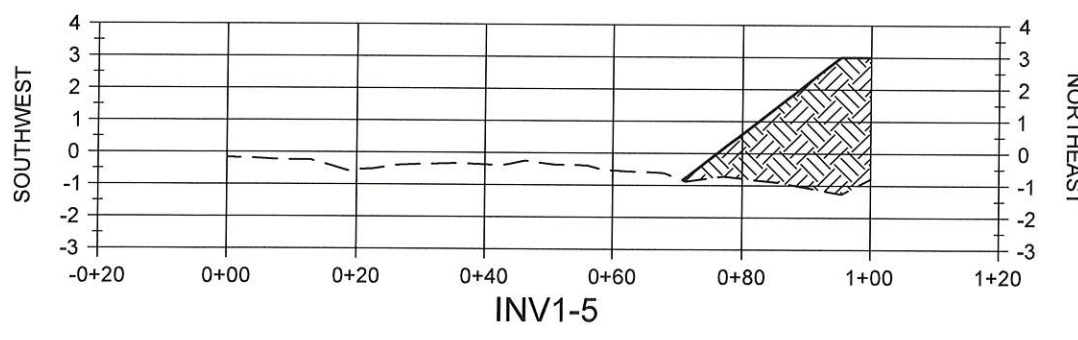
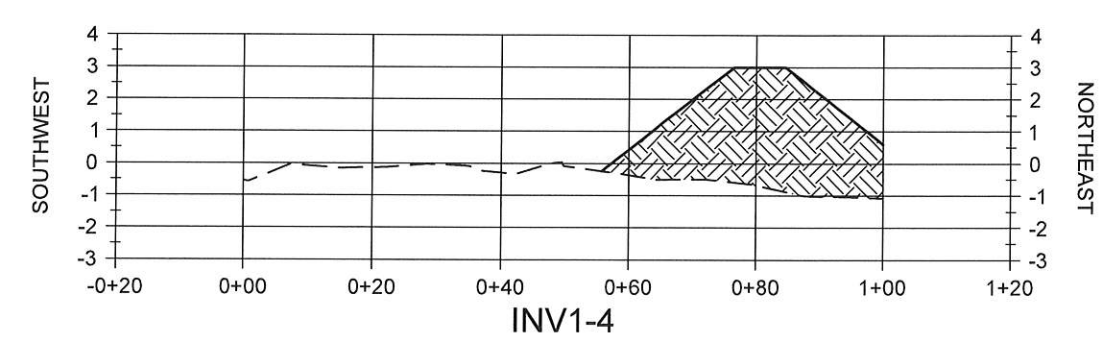
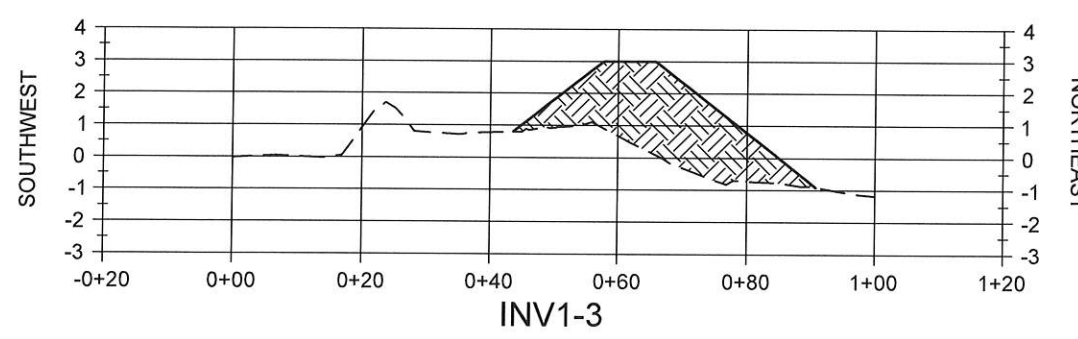
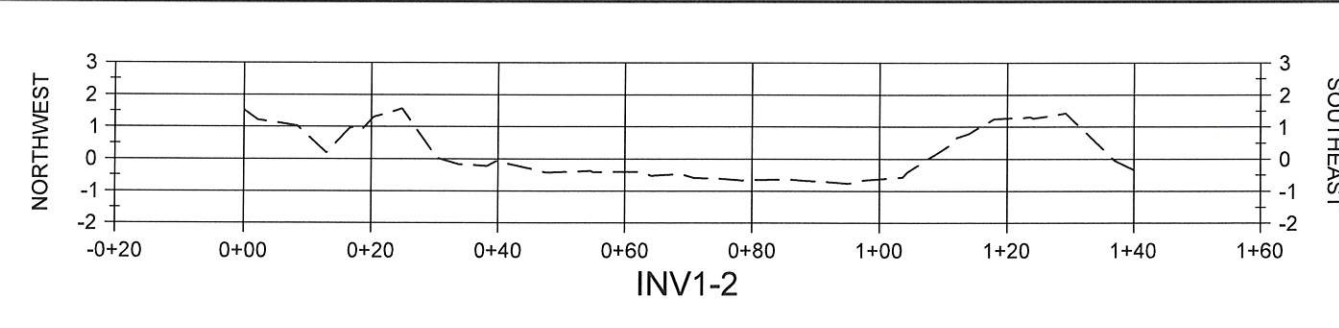
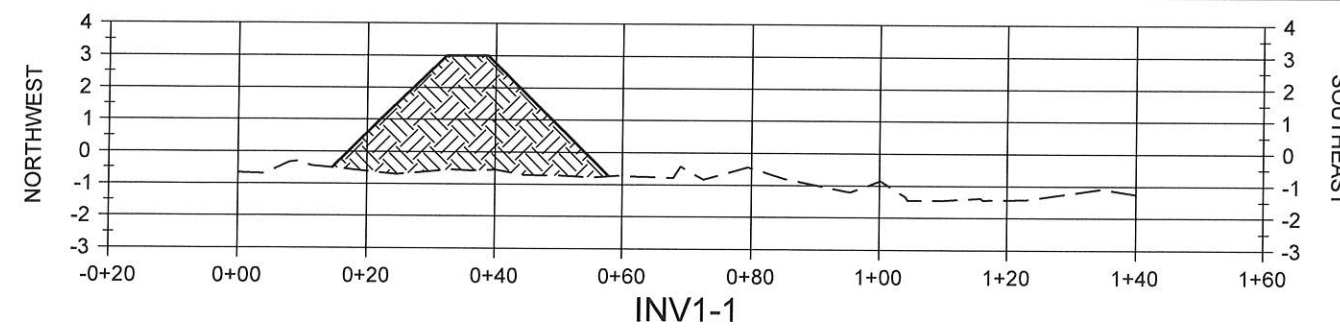

NOTE:
ALL ELEVATIONS ARE GIVEN IN THE
NORTH AMERICAN VERTICAL DATUM
OF 1988 (NAVD88) GEOID 12A.

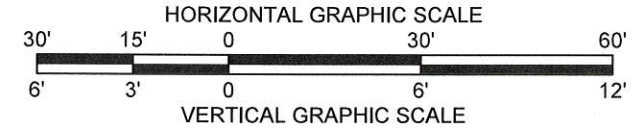

LEGEND	
	EARTHEN CONTAINMENT DIKE
	MARSH CREATION FILL
	EXISTING GRADE

COASTAL PROTECTION AND RESTORATION AUTHORITY 150 TERRACE AVENUE BATON ROUGE, LOUISIANA 70802		DATE	REV.	DESCRIPTION	BY
WEST MARSH CREATION AREA SECTIONS		DESIGNED BY: T. MCCLAIN, E.I.	APPROVED BY: T. FITZGERALD, P.E.	P.E. NO. 38153	
NORTHWEST TURTLE BAY MARSH CREATION PROJECT		STATE PROJECT NUMBER: BA-0125	DRAWN BY: K. CANTU		
DATE: DEC. 2018		SHEET 60 OF 79			

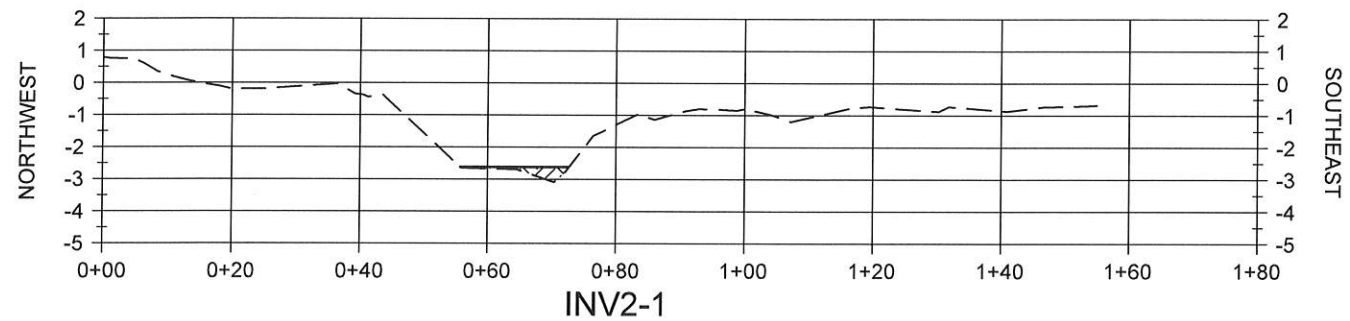

INV2-1

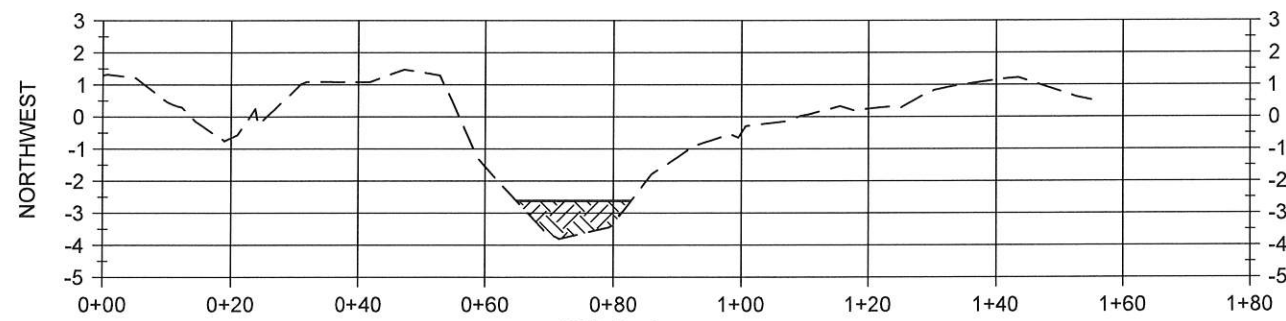

INV2-2

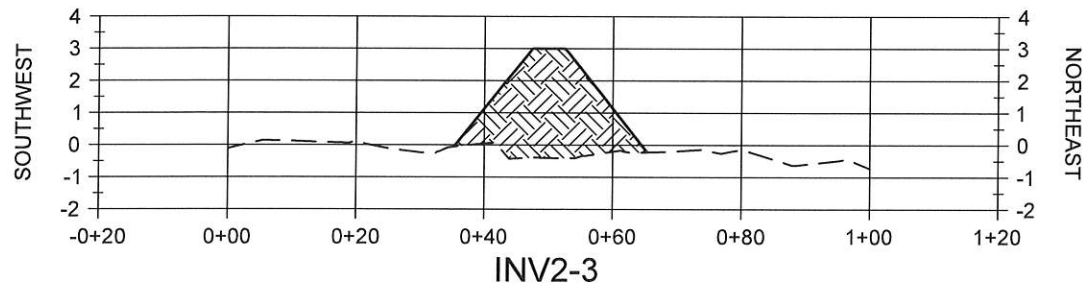

INV2-3

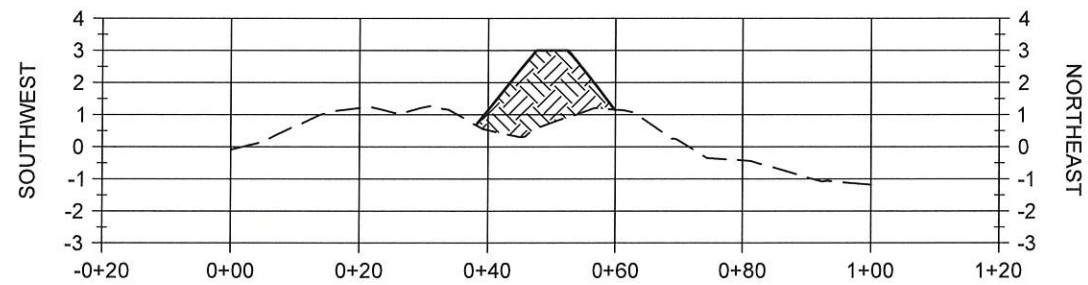

INV2-4

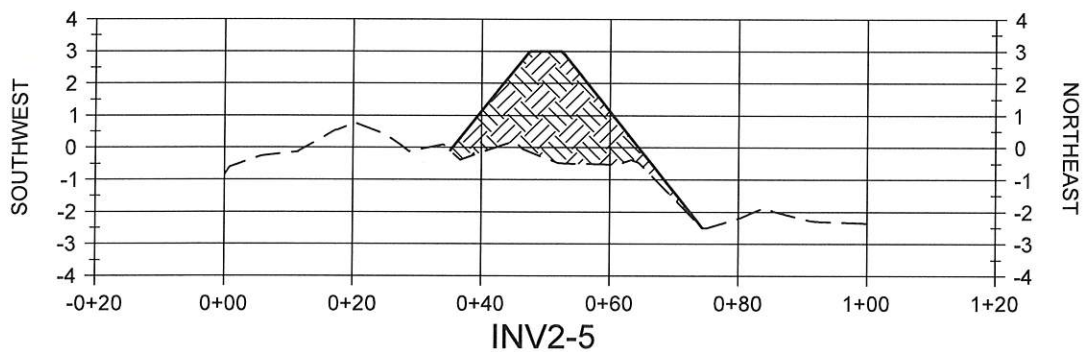

INV2-5

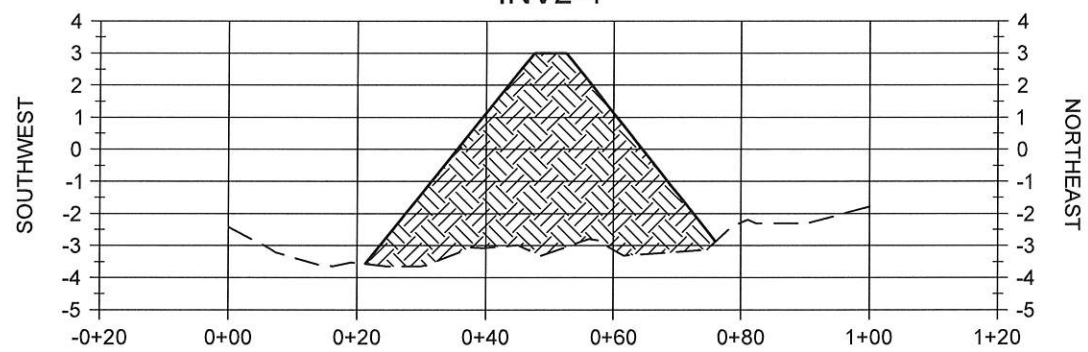

INV2-6

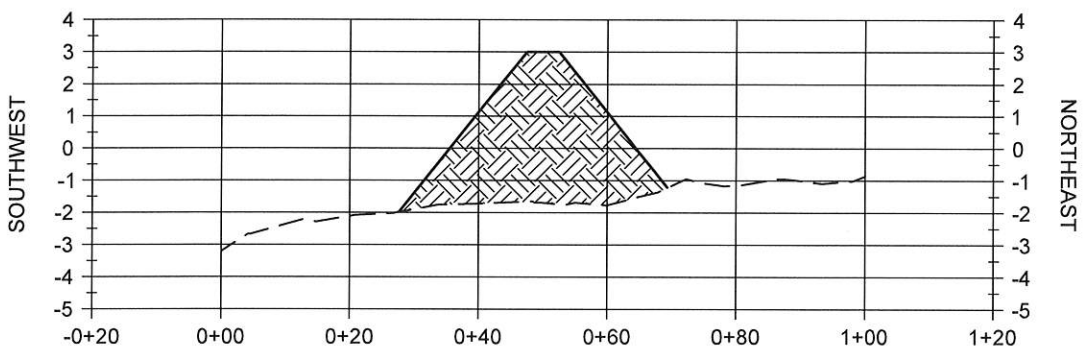

INV2-7

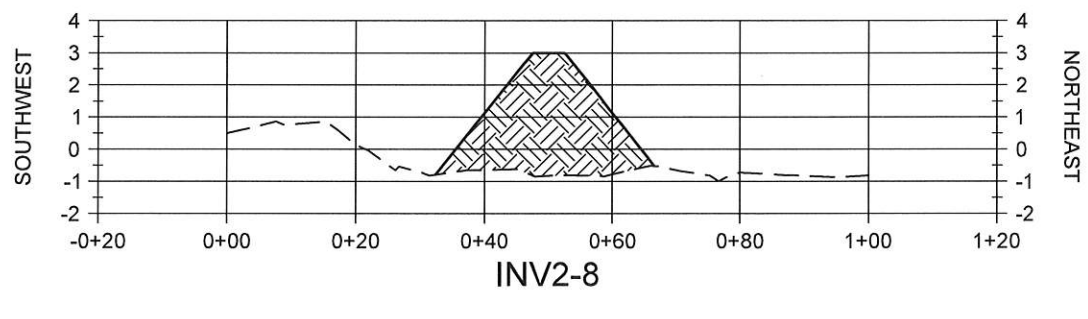

INV2-8

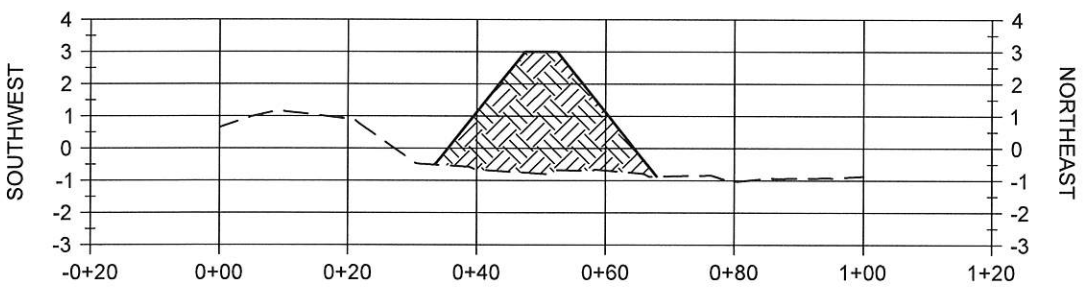

INV2-9

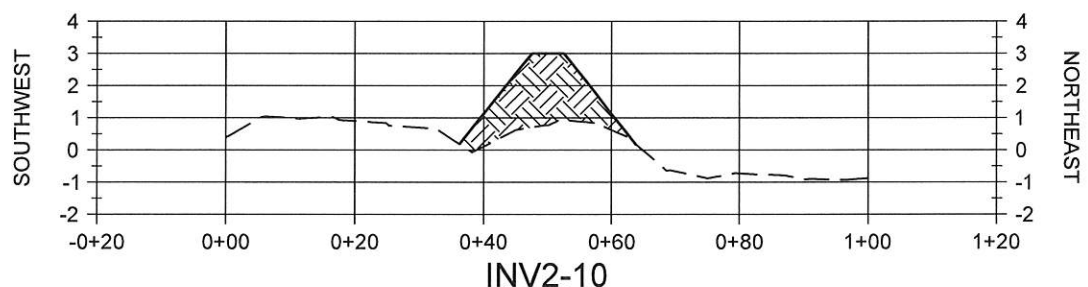

INV2-10

NOTE:
ALL ELEVATIONS ARE GIVEN IN THE
NORTH AMERICAN VERTICAL DATUM
OF 1988 (NAVD88) GEOID 12A.

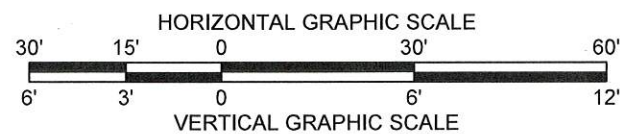

LEGEND	
	EARTHEN CONTAINMENT DIKE
	MARSH CREATION FILL
	EXISTING GRADE

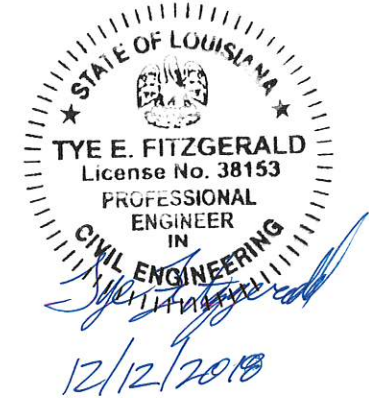

REV.	DATE	DESCRIPTION	BY

COASTAL PROTECTION AND
RESTORATION AUTHORITY
150 TERRACE AVENUE
BATON ROUGE, LOUISIANA 70802

WEST MARSH CREATION
AREA SECTIONS
DESIGNED BY: T. MCLAIN, E.I.
APPROVED BY: T. FITZGERALD, P.E. P.E. NO. 38153

NORTHWEST TURTLE BAY
MARSH CREATION PROJECT
STATE PROJECT NUMBER: BA-0125
DRAWN BY: K. CANTU

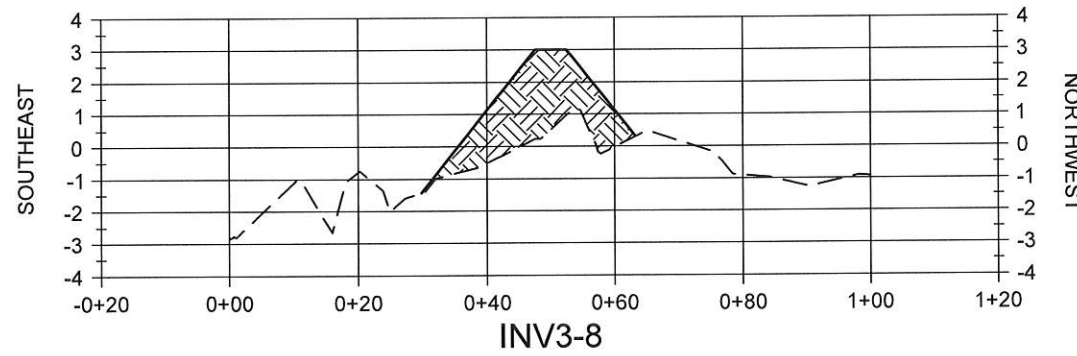
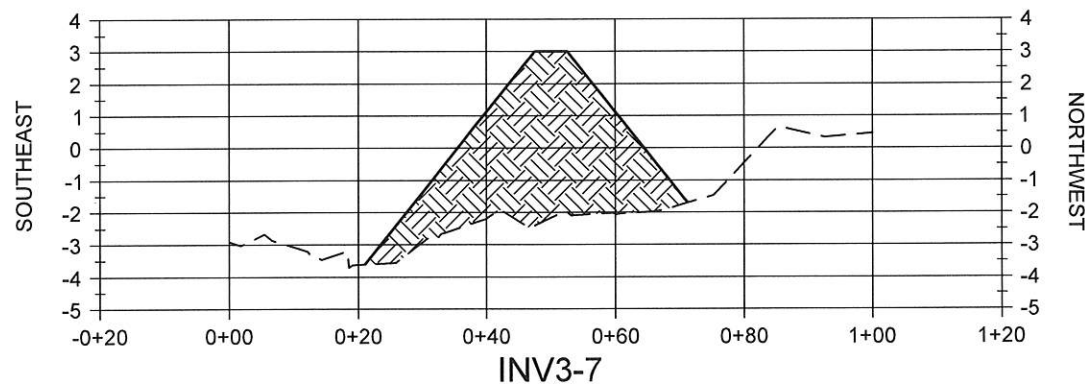
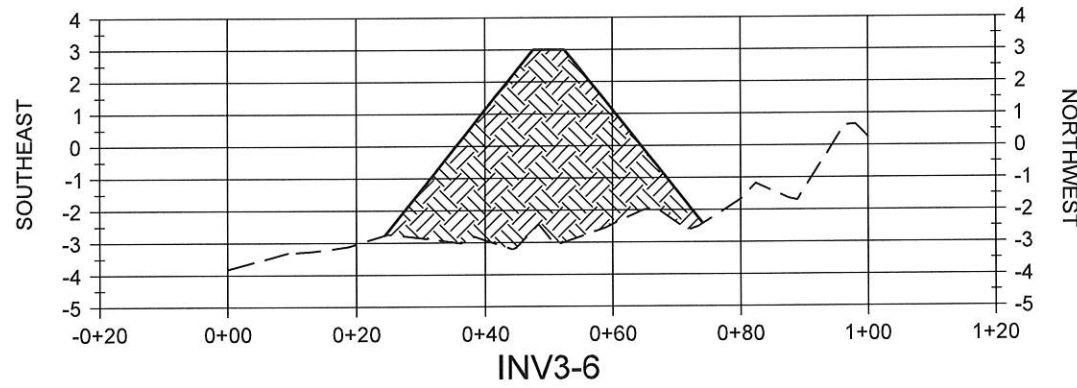
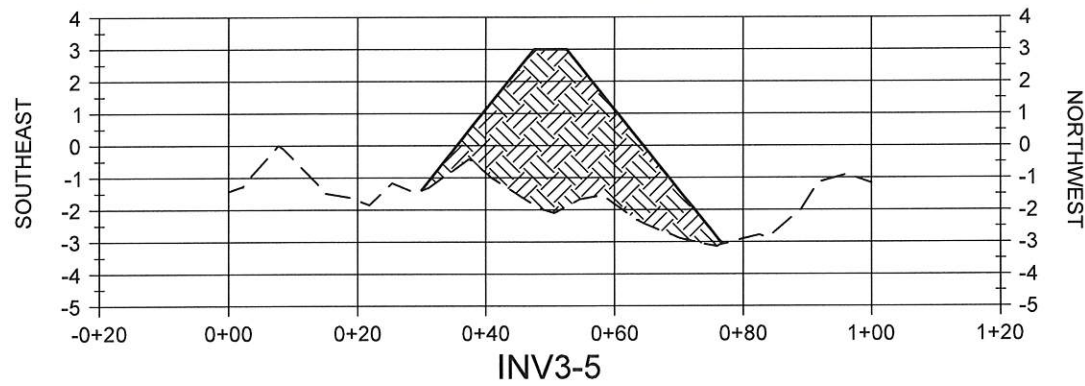
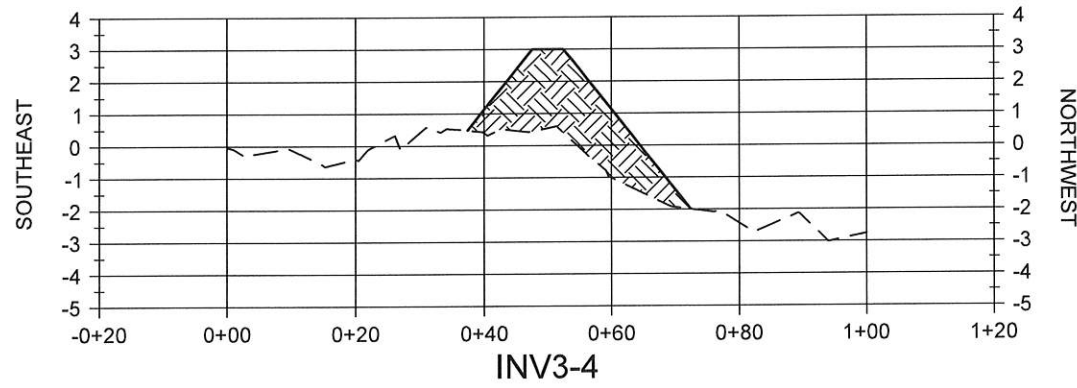
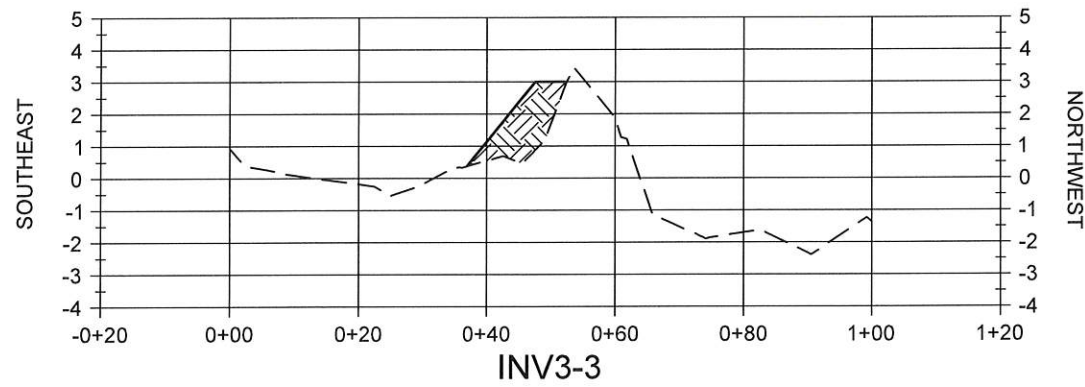
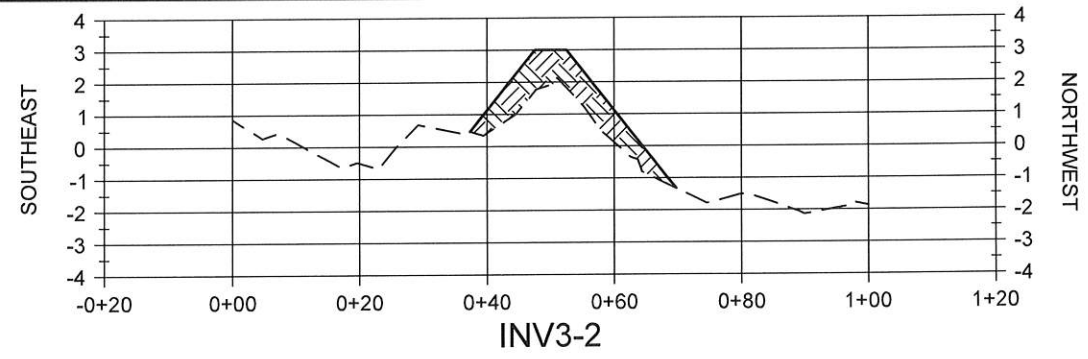
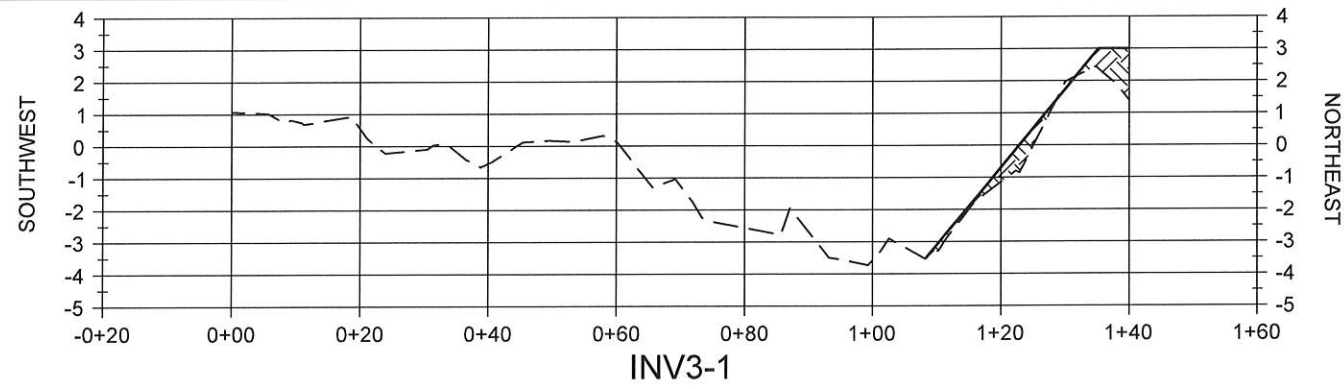

NOTE:
ALL ELEVATIONS ARE GIVEN IN THE
NORTH AMERICAN VERTICAL DATUM
OF 1988 (NAVD88) GEOID 12A.

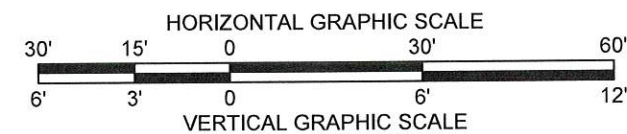

LEGEND	
	EARTHEN CONTAINMENT DIKE
	MARSH CREATION FILL
	EXISTING GRADE

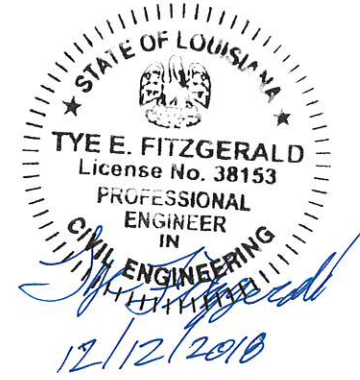

COASTAL PROTECTION AND RESTORATION AUTHORITY 150 TERRACE AVENUE BATON ROUGE, LOUISIANA 70802		REV.	DATE	BY
WEST MARSH CREATION AREA SECTIONS		DESIGNED BY: T. MCLAIN, E.I. APPROVED BY: T. FITZGERALD, P.E. P.E. NO. 38153		
		NORTHWEST TURTLE BAY MARSH CREATION PROJECT STATE PROJECT NUMBER: BA-0125 DRAWN BY: K. CANTU		
DATE: DEC. 2018		SHEET 62 OF 79		

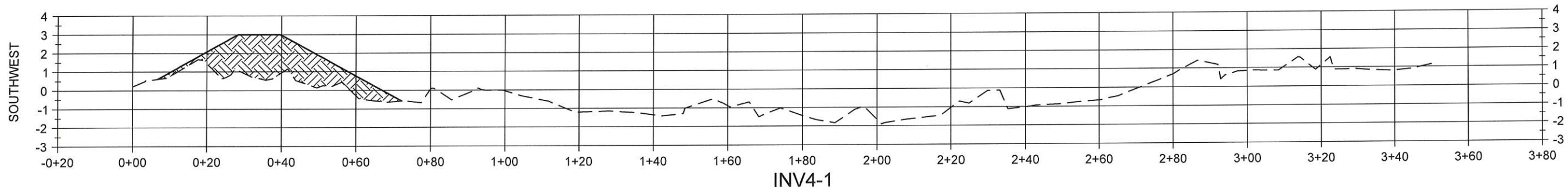

INV4-1

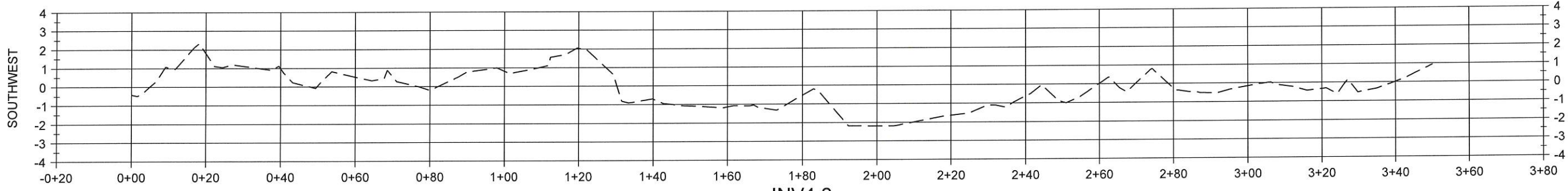

INV4-2

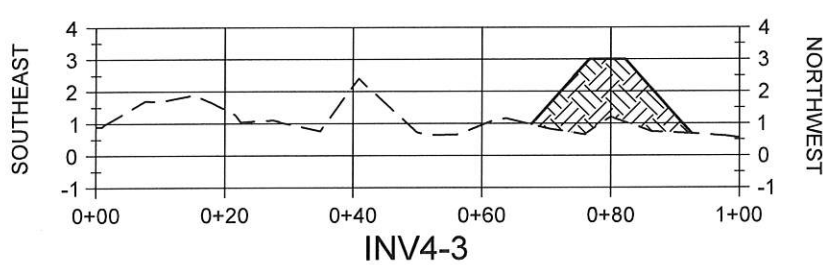

INV4-3

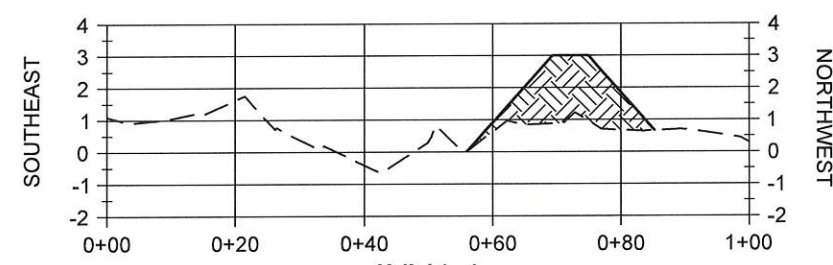

INV4-4

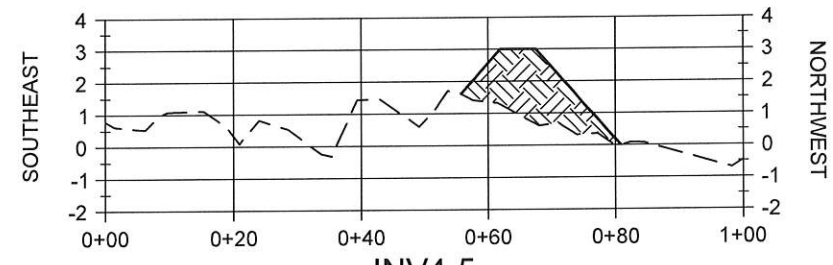

INV4-5

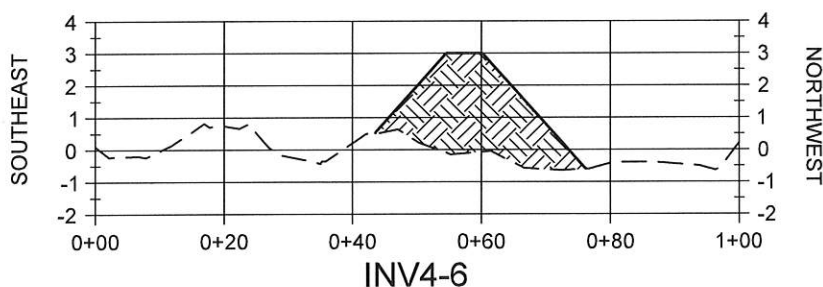

INV4-6

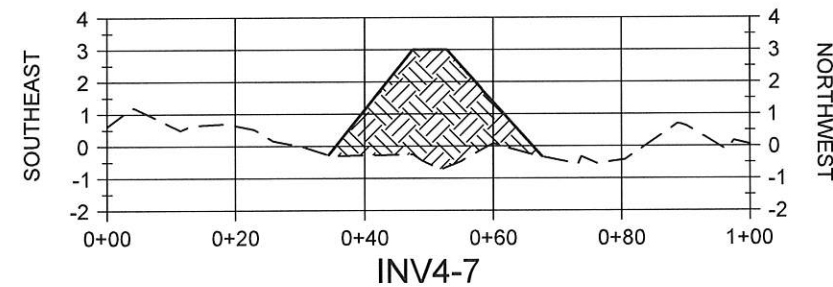

INV4-7

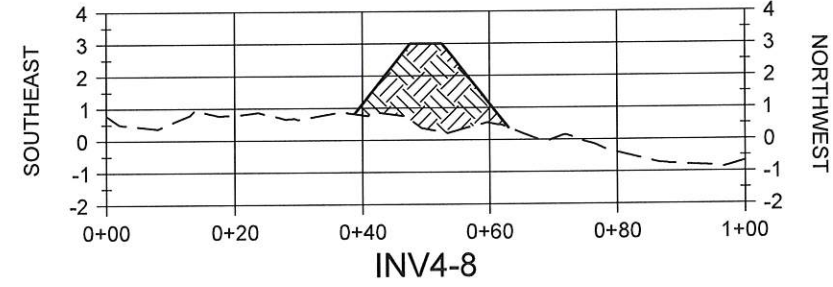

INV4-8

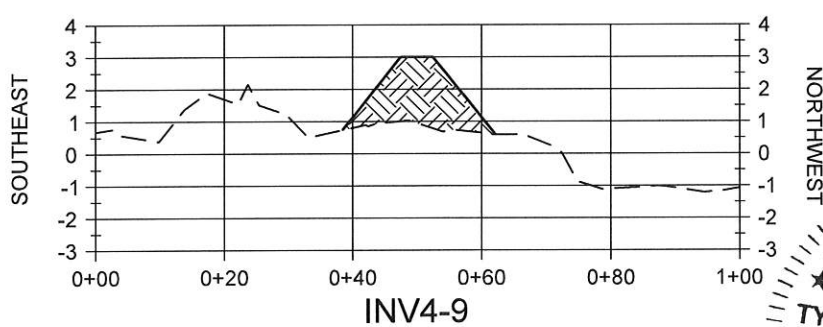

INV4-9

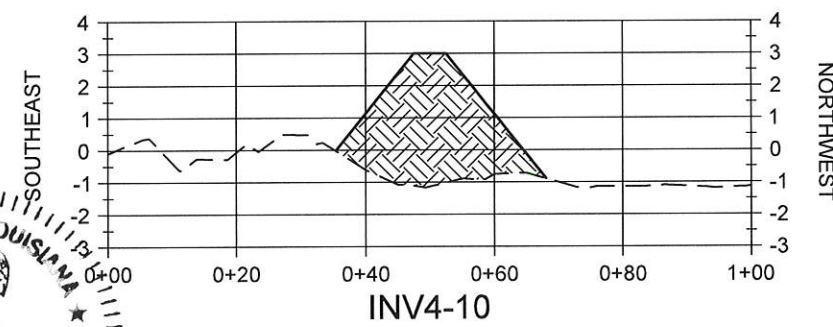

INV4-10

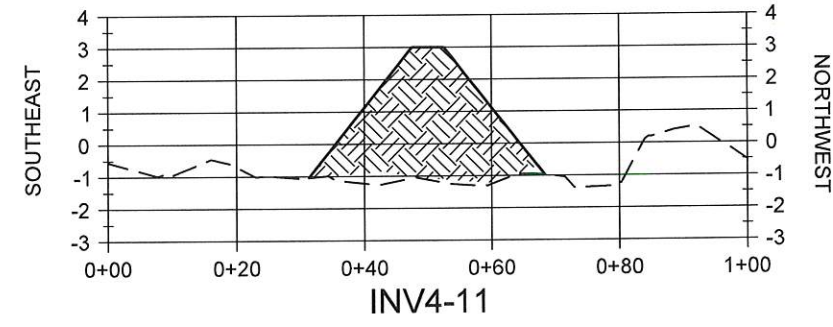

INV4-11

STATE OF LOUISIANA
 TYE E. FITZGERALD
 License No. 38153
 PROFESSIONAL
 ENGINEER
 IN
 CIVIL ENGINEERING

Tye E. Fitzgerald

12/12/2018

NOTE:
 ALL ELEVATIONS ARE GIVEN IN THE
 NORTH AMERICAN VERTICAL DATUM
 OF 1988 (NAVD88) GEOID 12A.

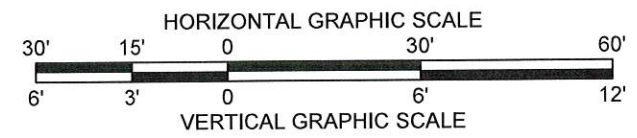

LEGEND	
	EARTHEN CONTAINMENT DIKE
	MARSH CREATION FILL
	EXISTING GRADE

COASTAL PROTECTION AND RESTORATION AUTHORITY 150 TERRACE AVENUE BATON ROUGE, LOUISIANA 70802		DATE	DESCRIPTION	BY
WEST MARSH CREATION AREA SECTIONS		DESIGNED BY: T. MCLAIN, E.I.	APPROVED BY: T. FITZGERALD, P.E.	P.E. NO. 38153
NORTHWEST TURTLE BAY MARSH CREATION PROJECT		STATE PROJECT NUMBER: BA-0125	DRAWN BY: K. CANTU	
DATE: DEC. 2018		SHEET 63 OF 79		

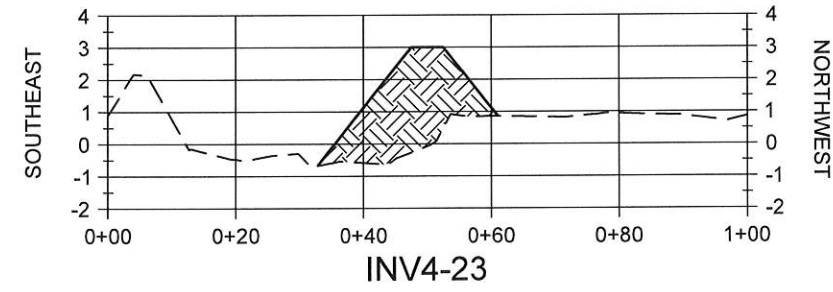
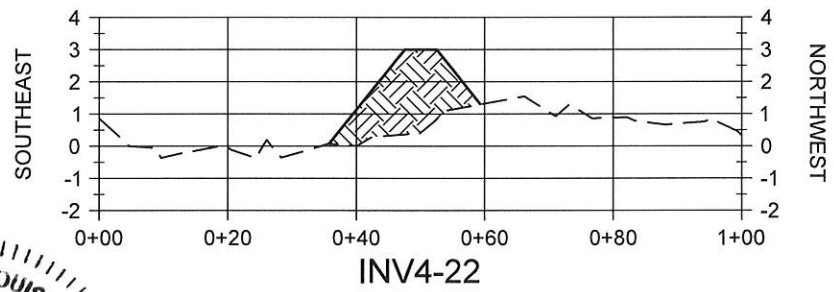
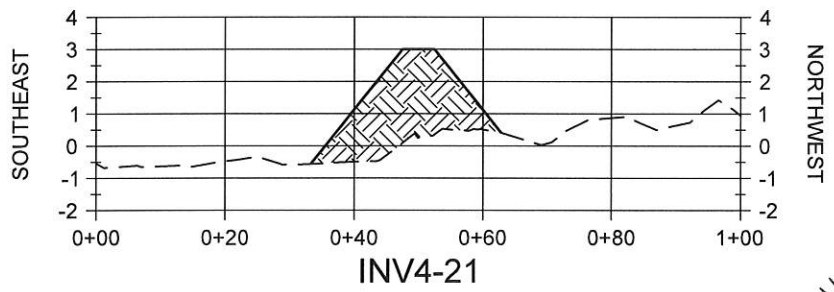
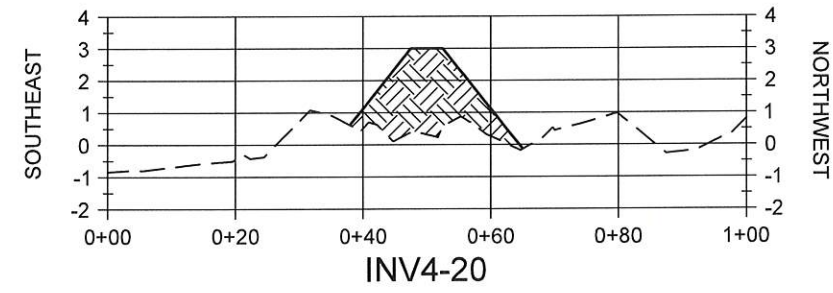
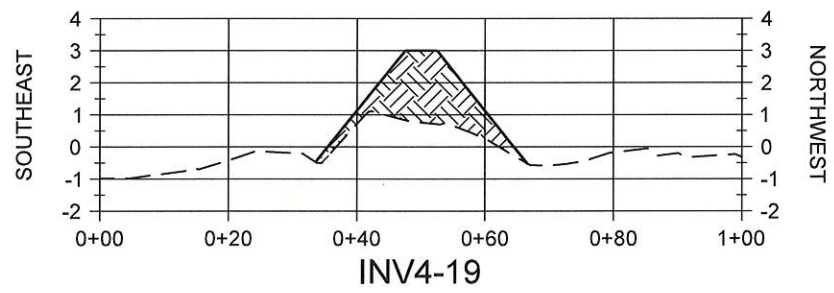
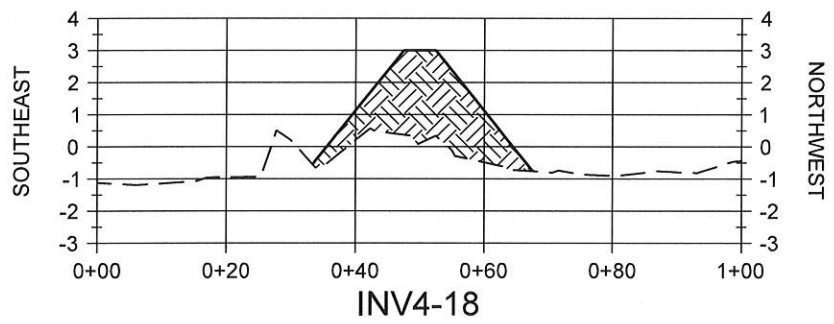
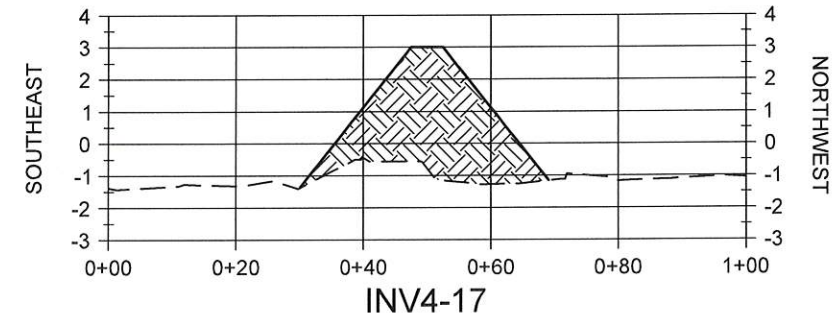
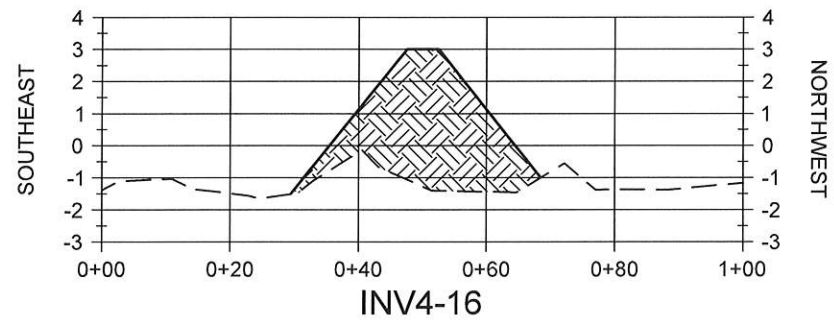
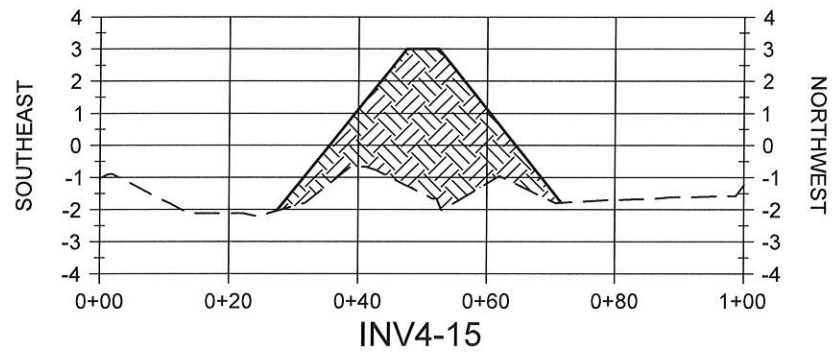
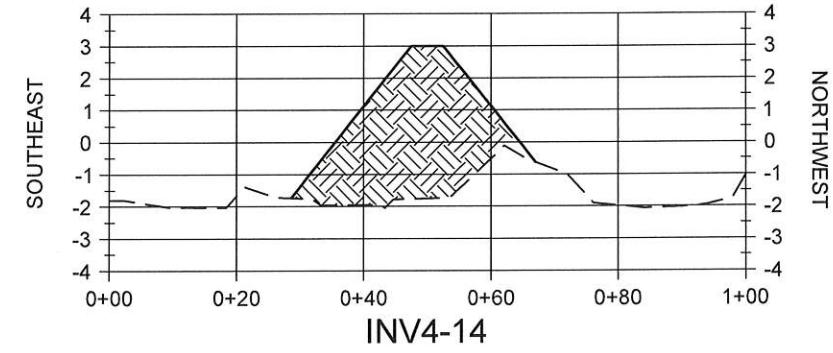
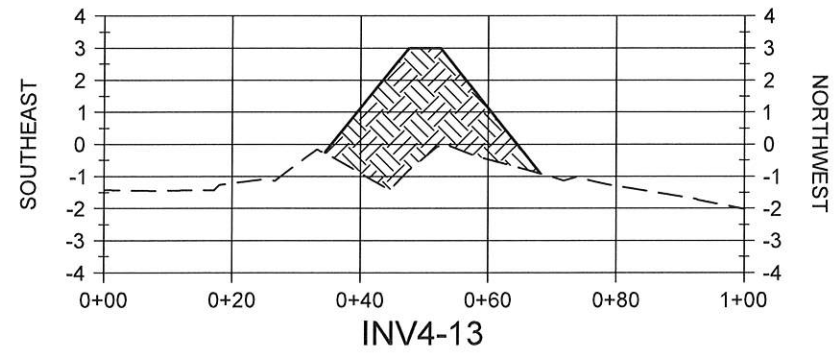
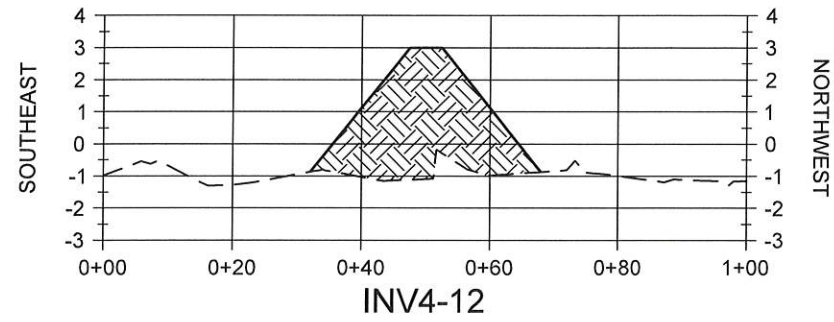

STATE OF LOUISIANA
 TYE E. FITZGERALD
 License No. 38153
 PROFESSIONAL ENGINEER
 IN
 CIVIL ENGINEERING
 12/12/2010

NOTE:
 ALL ELEVATIONS ARE GIVEN IN THE
 NORTH AMERICAN VERTICAL DATUM
 OF 1988 (NAVD88) GEOID 12A.

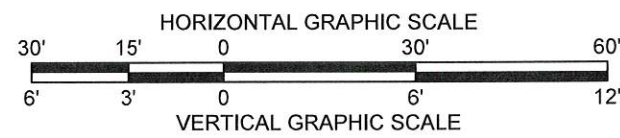

LEGEND	
	EARTHEN CONTAINMENT DIKE
	MARSH CREATION FILL
	EXISTING GRADE

COASTAL PROTECTION AND RESTORATION AUTHORITY 150 TERRACE AVENUE BATON ROUGE, LOUISIANA 70802		DATE	DESCRIPTION	BY
WEST MARSH CREATION AREA SECTIONS		REV.		
NORTHWEST TURTLE BAY MARSH CREATION PROJECT		DATE	DESCRIPTION	BY
STATE PROJECT NUMBER: BA-0125	DESIGNED BY: T. MCLAIN, E.I.			
DRAWN BY: K. CANTU	APPROVED BY: T. FITZGERALD, P.E.			P.E. NO. 38153
DATE: DEC. 2018		SHEET 64 OF 79		

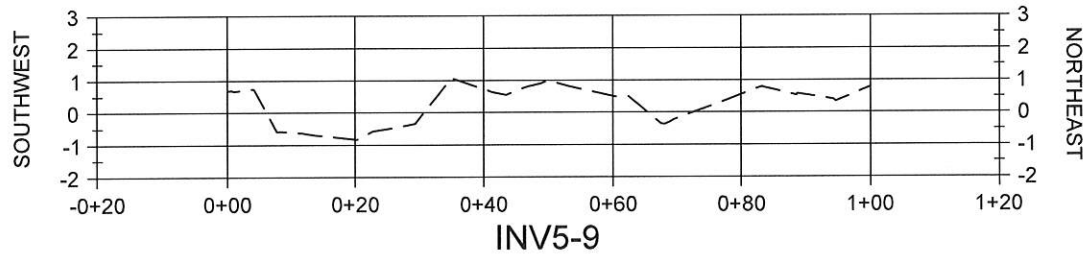
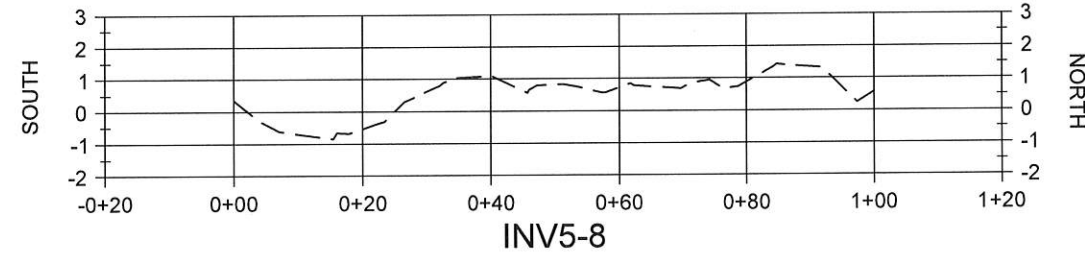
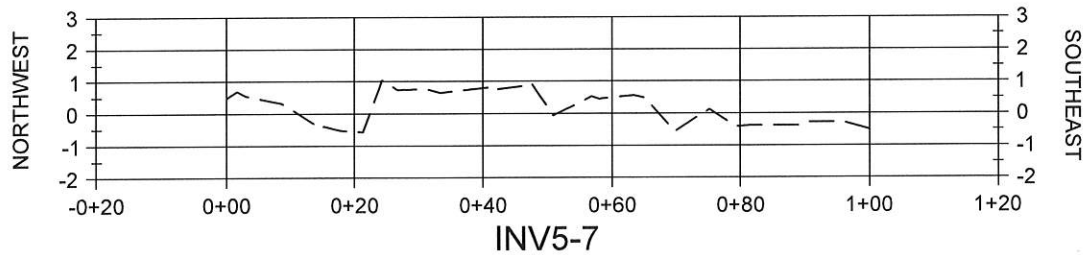
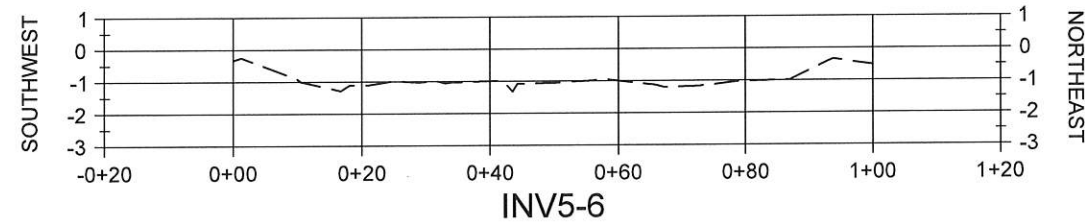
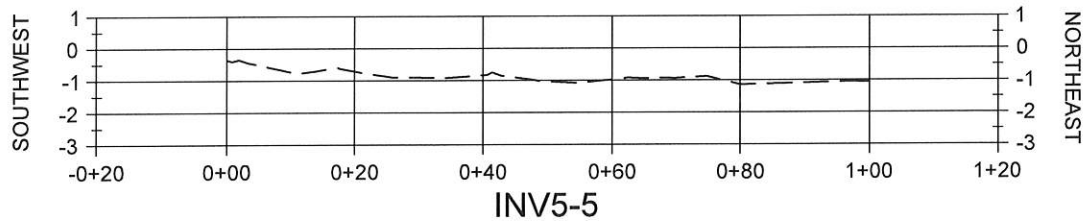
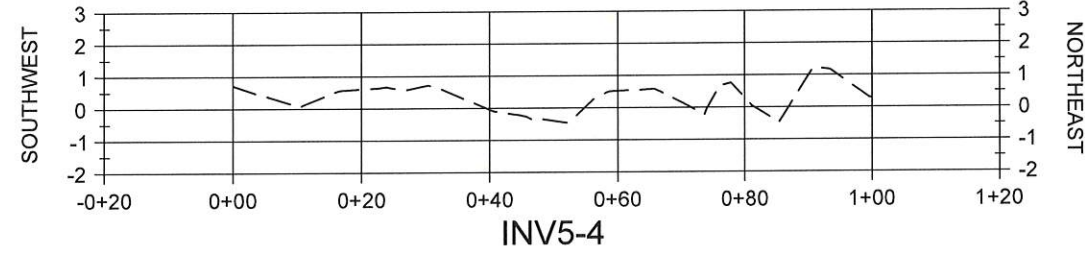
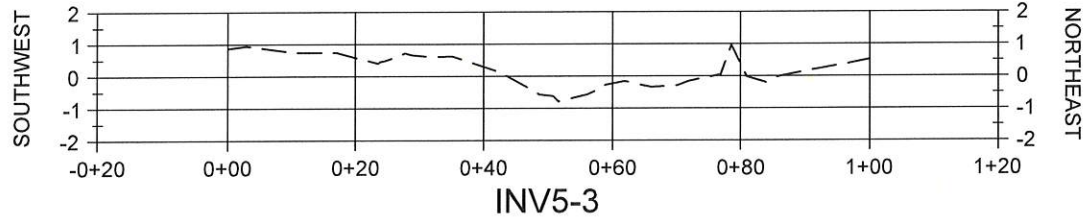
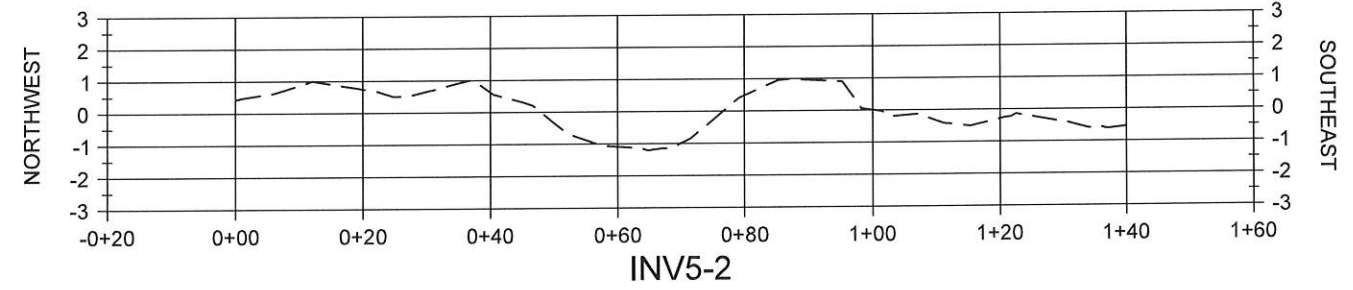
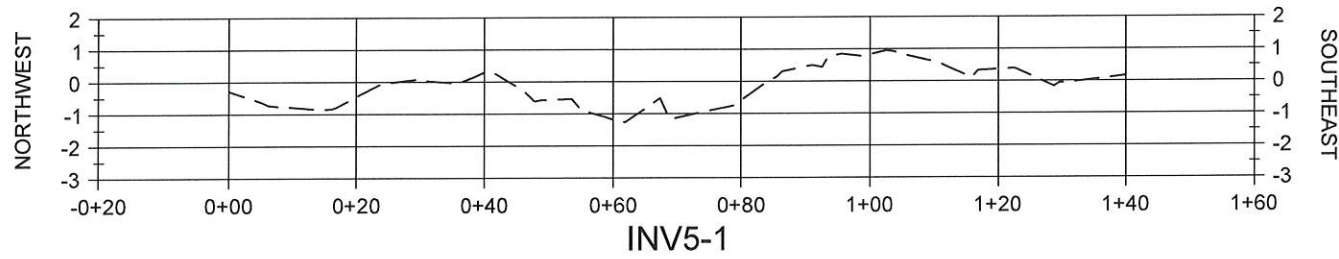

NOTE:
ALL ELEVATIONS ARE GIVEN IN THE
NORTH AMERICAN VERTICAL DATUM
OF 1988 (NAVD88) GEOID 12A.

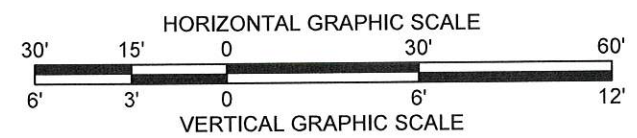

LEGEND	
	EARTHEN CONTAINMENT DIKE
	MARSH CREATION FILL
	EXISTING GRADE



COASTAL PROTECTION AND RESTORATION AUTHORITY 150 TERRACE AVENUE BATON ROUGE, LOUISIANA 70802		REV.	DATE	BY
WEST MARSH CREATION AREA SECTIONS		DESIGNED BY: T. MCLAIN, E.I. APPROVED BY: T. FITZGERALD, P.E. P.E. NO. 38153		
		NORTHWEST TURTLE BAY MARSH CREATION PROJECT		
STATE PROJECT NUMBER: BA-0125		DRAWN BY: K. CANTU		
DATE: DEC. 2018		SHEET 65 OF 79		

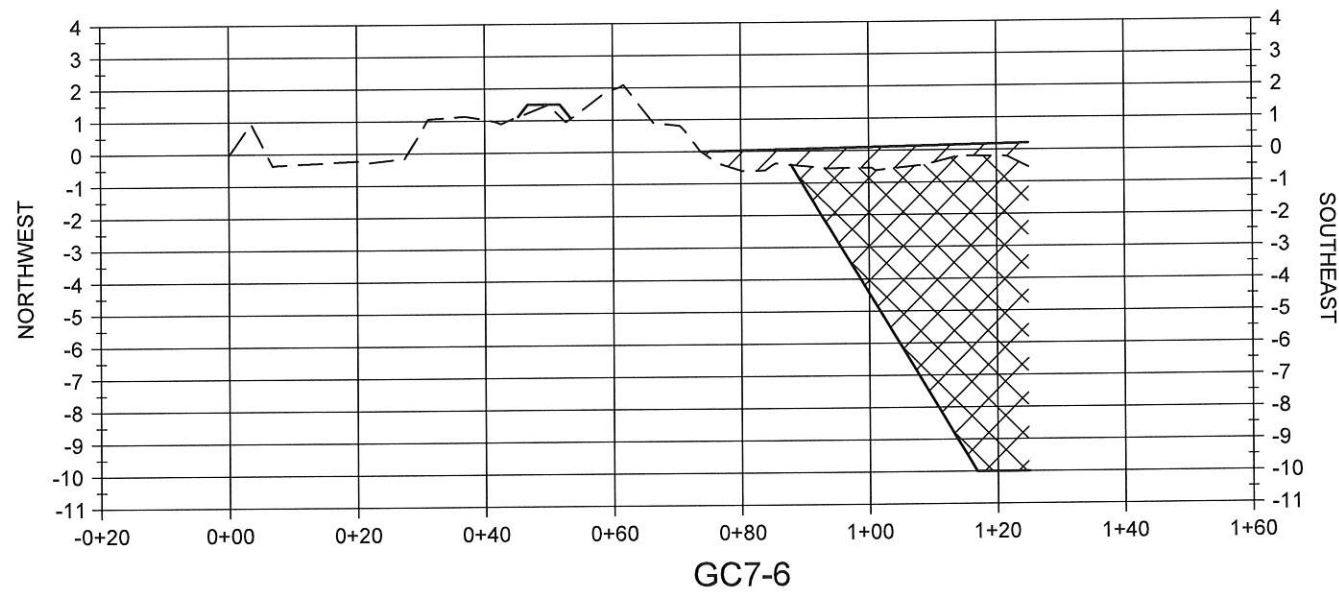
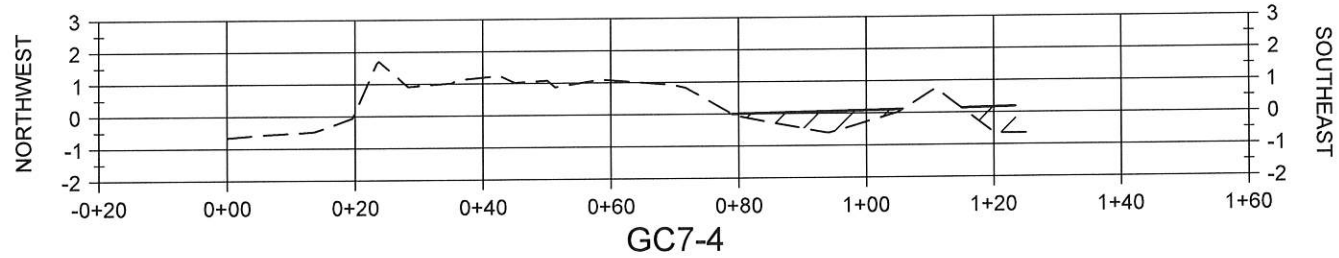
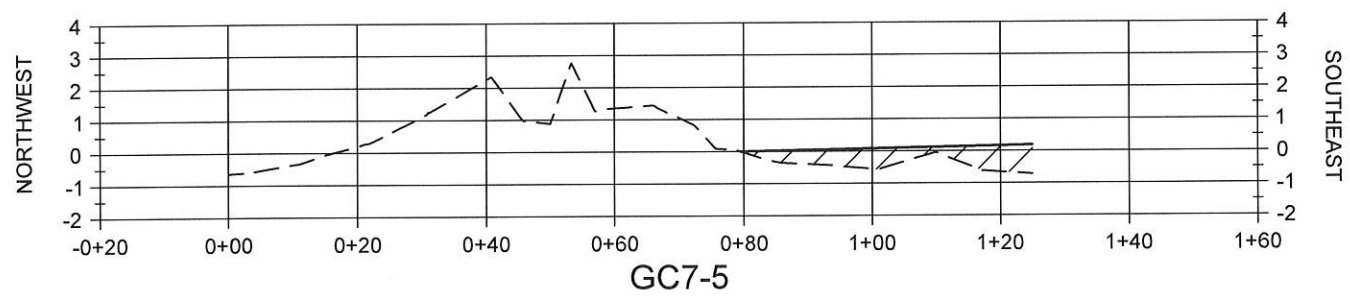
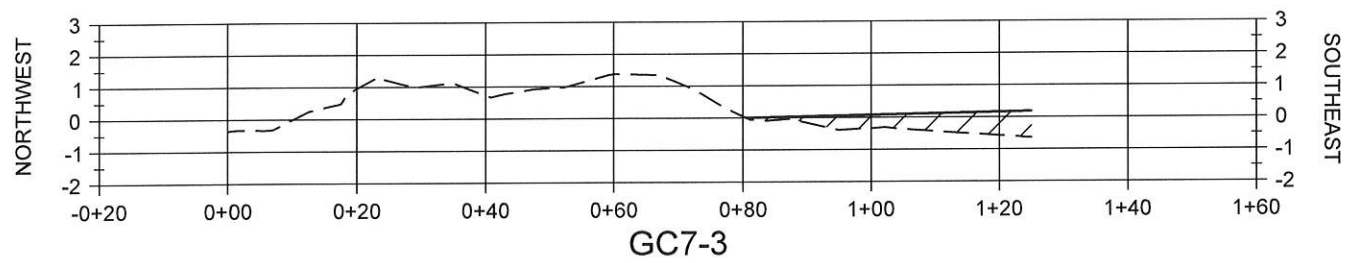
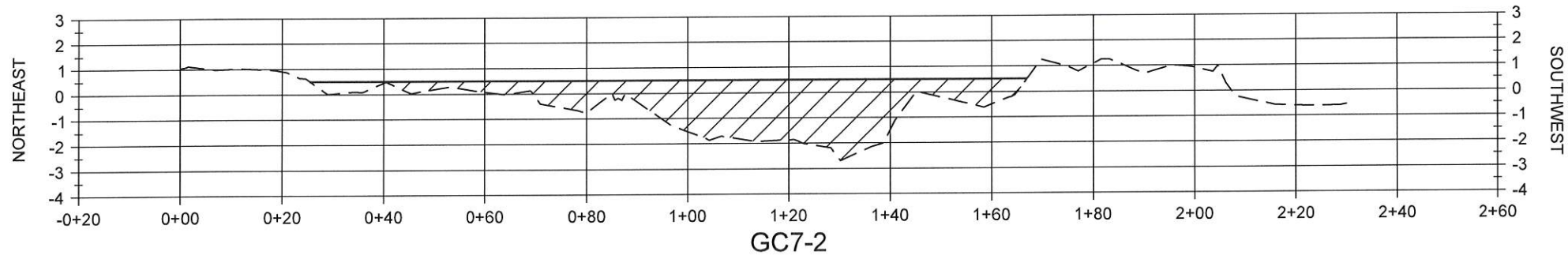
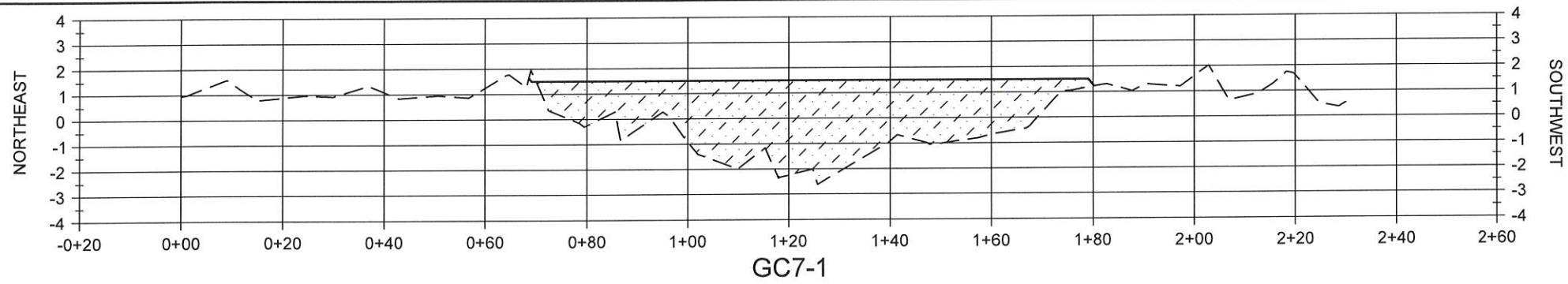

STATE OF LOUISIANA
 TYE E. FITZGERALD
 License No. 38153
 PROFESSIONAL ENGINEER
 CIVIL ENGINEERING
 150 TERRACE AVENUE
 BATON ROUGE, LOUISIANA 70802
 12/12/2018

NOTE:
 ALL ELEVATIONS ARE GIVEN IN THE NORTH AMERICAN
 VERTICAL DATUM OF 1988 (NAVD88) GEOID 12A.

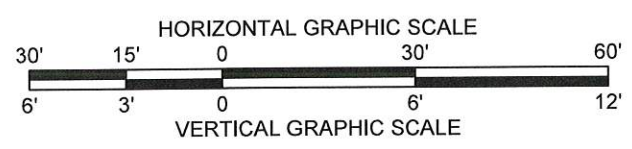

LEGEND	
	EARTHEN GAP CLOSURE
	EARTHEN GAP CLOSURE BORROW AREA
	MARSH CREATION FILL
	EXISTING GRADE

REV.	DATE	DESCRIPTION	BY

COASTAL PROTECTION AND RESTORATION AUTHORITY 150 TERRACE AVENUE BATON ROUGE, LOUISIANA 70802	
WEST MARSH CREATION AREA SECTIONS	DESIGNED BY: T. MCLAIN, E.I. APPROVED BY: T. FITZGERALD, P.E. P.E. NO. 38153
NORTHWEST TURTLE BAY MARSH CREATION PROJECT STATE PROJECT NUMBER: BA-0125 DRAWN BY: K. CANTU	DATE: DEC. 2018 SHEET 66 OF 79

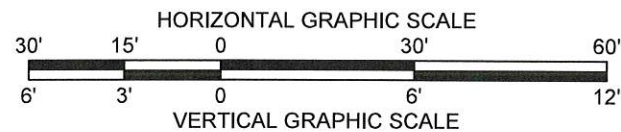
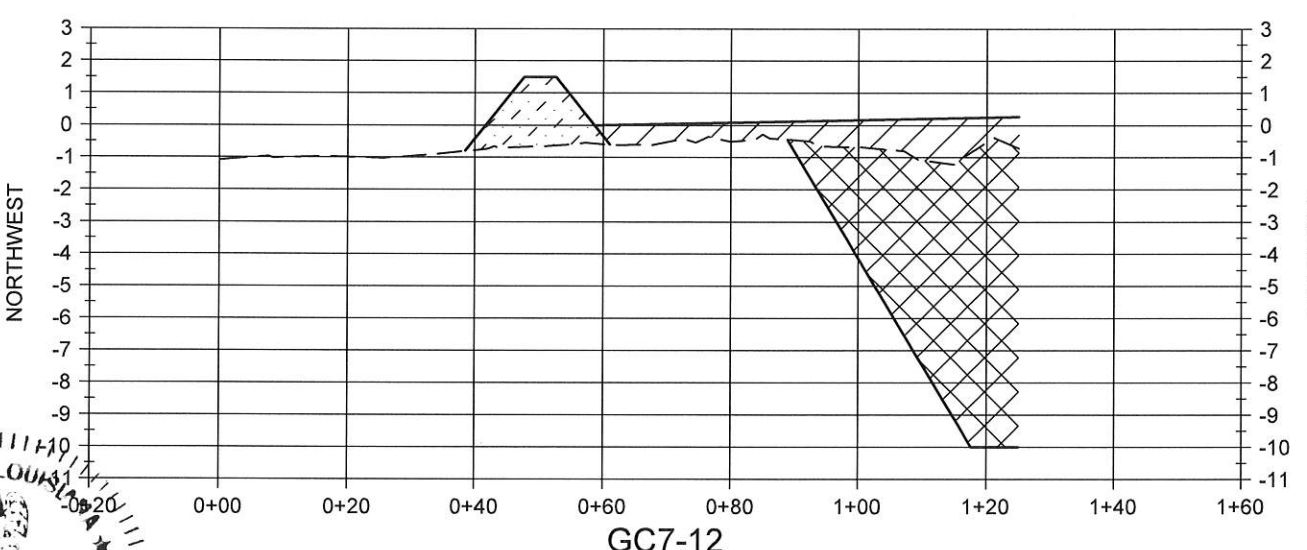
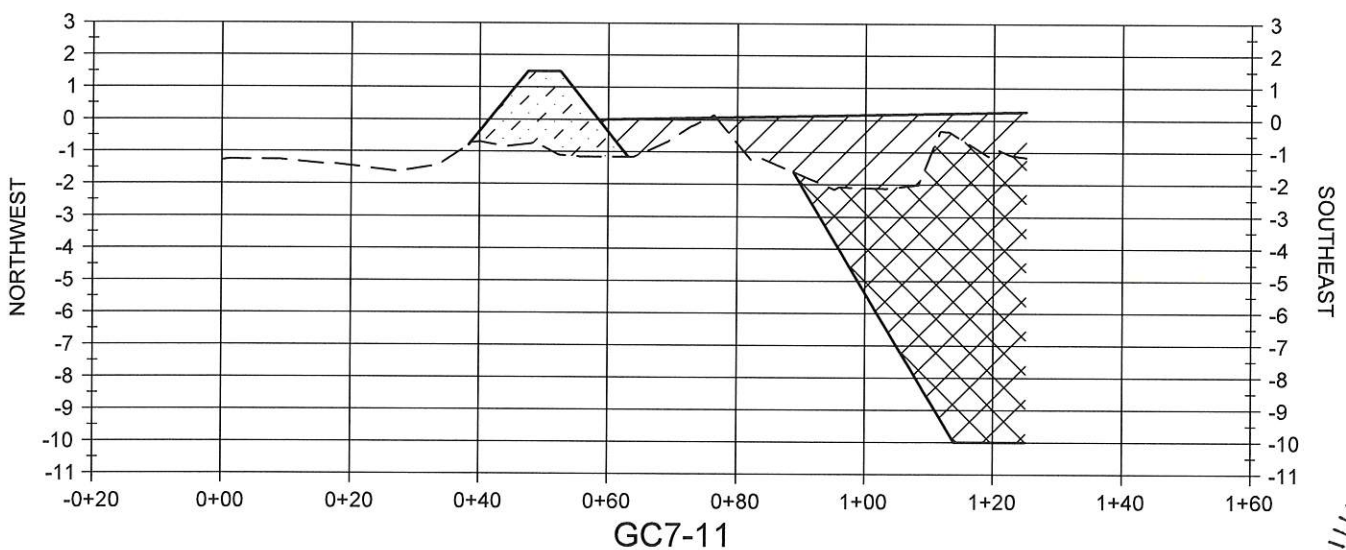
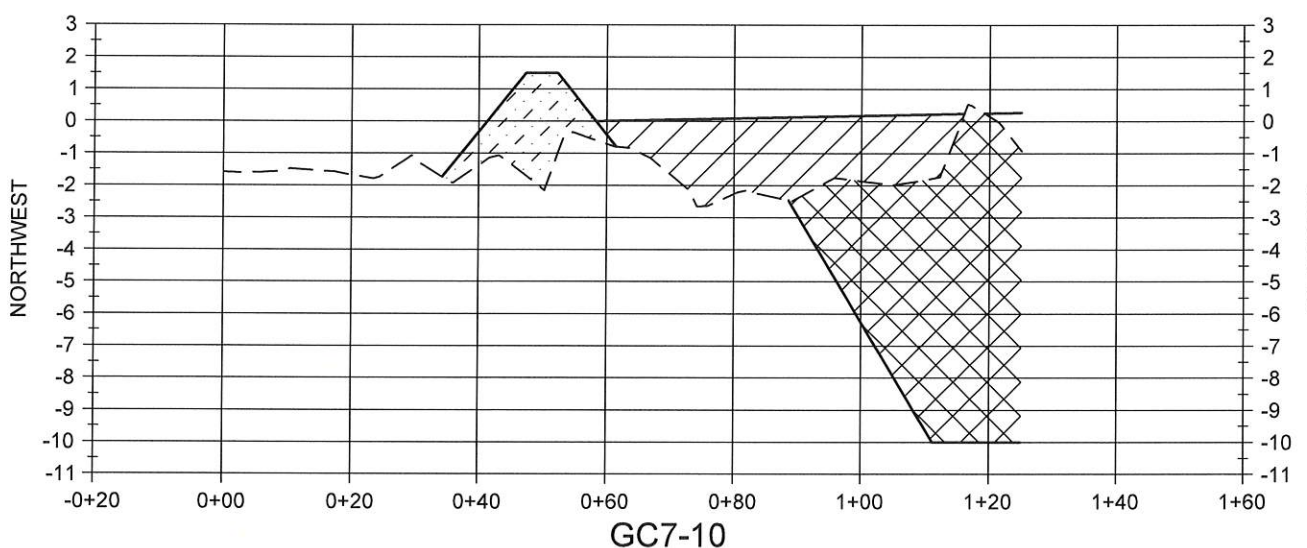
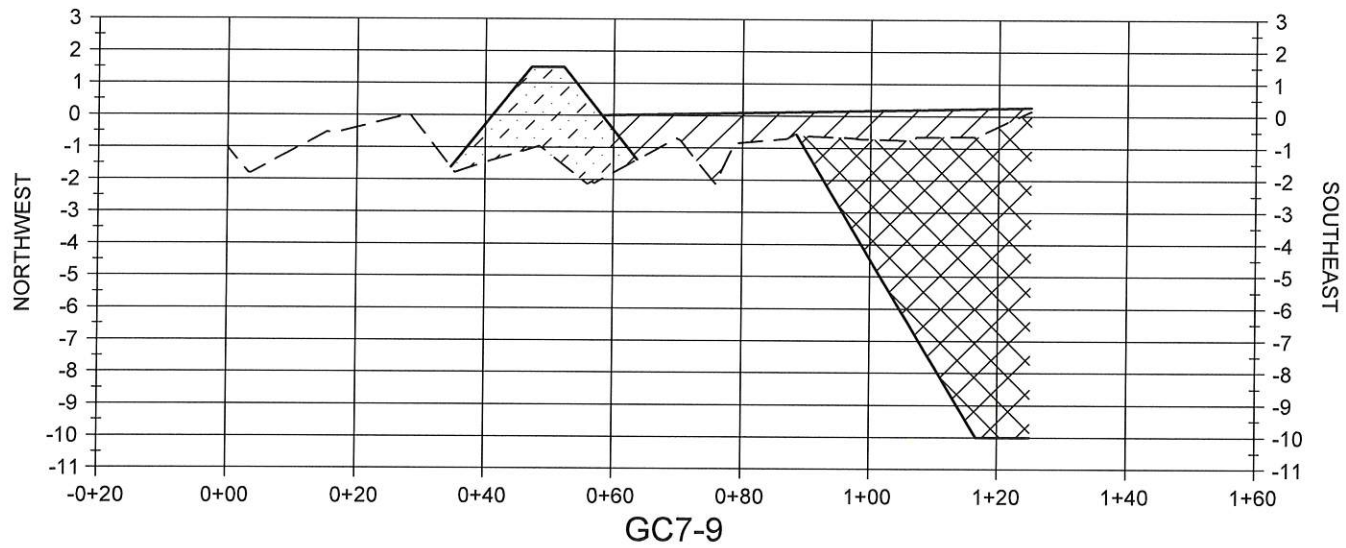
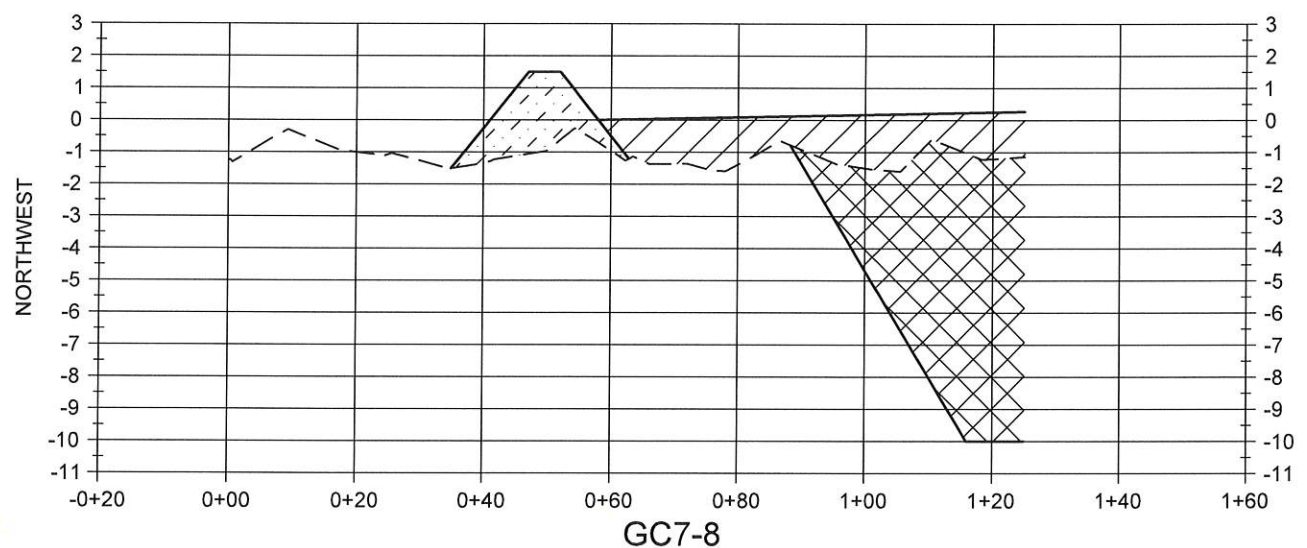
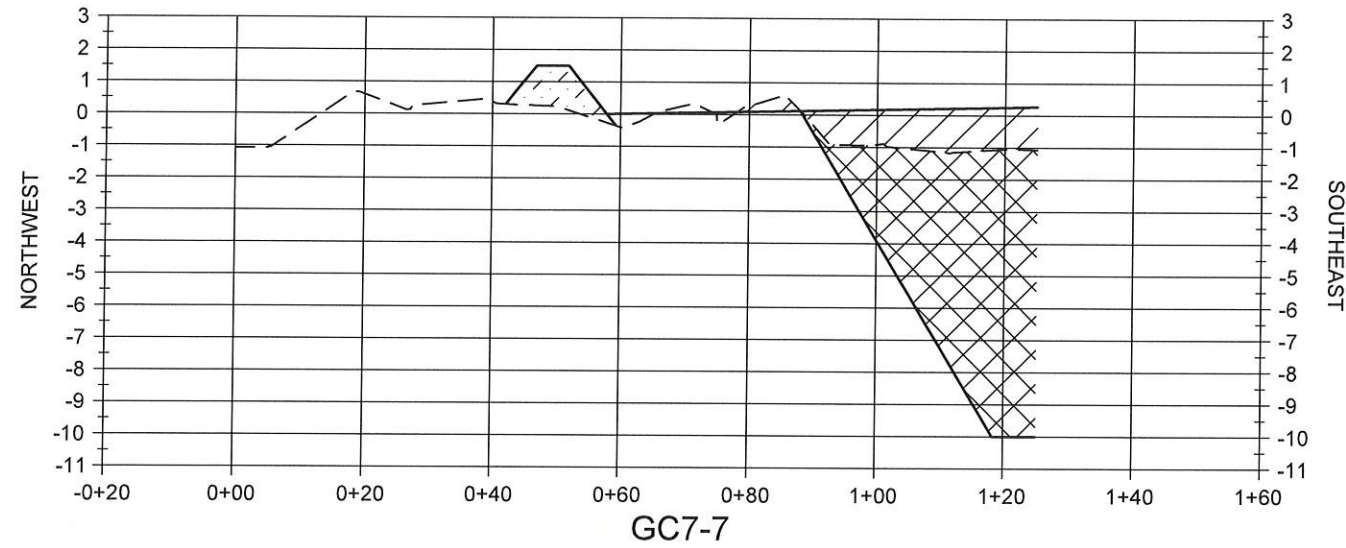

NOTE:
ALL ELEVATIONS ARE GIVEN IN THE NORTH AMERICAN
VERTICAL DATUM OF 1988 (NAVD88) GEOID 12A.

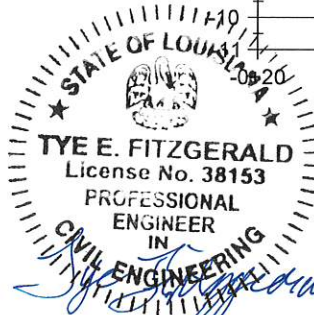

Tye E. Fitzgerald
12/12/2010

LEGEND	
	EARTHEN GAP CLOSURE
	EARTHEN GAP CLOSURE BORROW AREA
	MARSH CREATION FILL
	EXISTING GRADE

COASTAL PROTECTION AND RESTORATION AUTHORITY 150 TERRACE AVENUE BATON ROUGE, LOUISIANA 70802		DATE	DESCRIPTION	BY
WEST MARSH CREATION AREA SECTIONS		REV.		
DESIGNED BY: T. MCCLAIN, E.I.				
APPROVED BY: T. FITZGERALD, P.E. P.E. NO. 38153				
NORTHWEST TURTLE BAY MARSH CREATION PROJECT				
STATE PROJECT NUMBER: BA-0125				
DRAWN BY: K. CANTU				
DATE: DEC. 2018				
SHEET 67 OF 79				

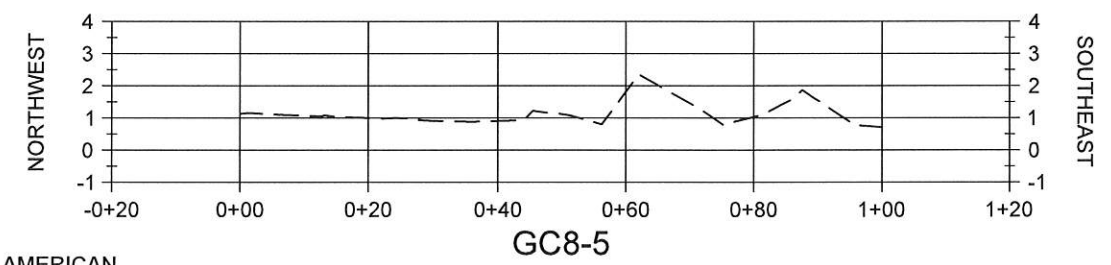
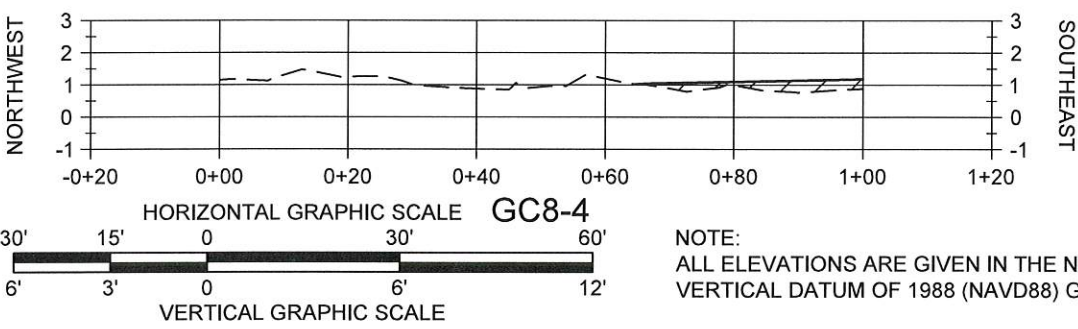
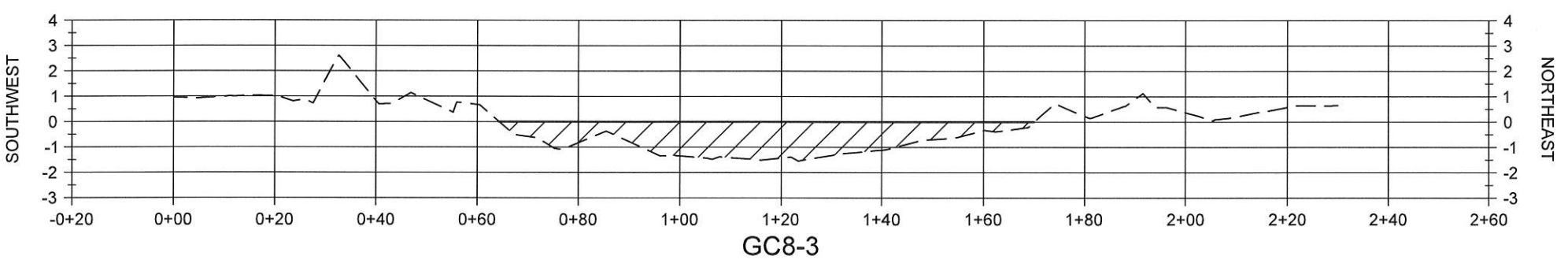
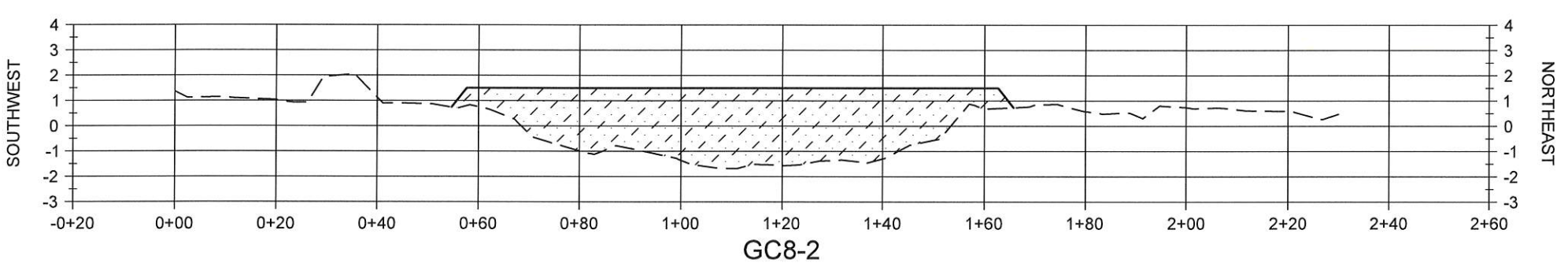
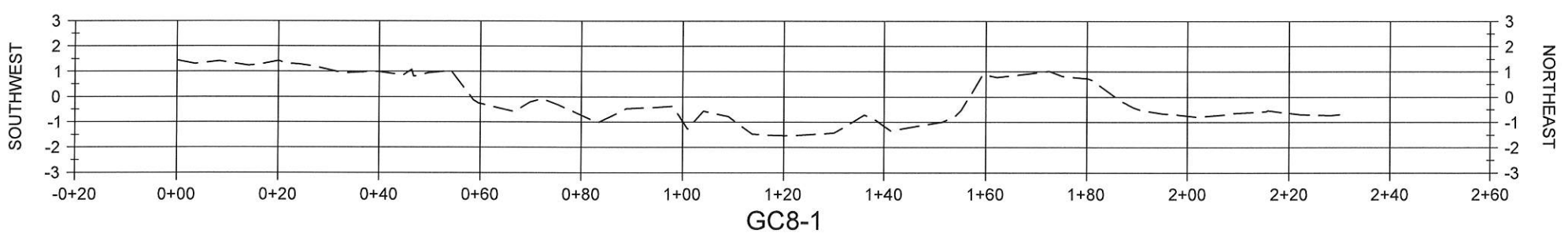
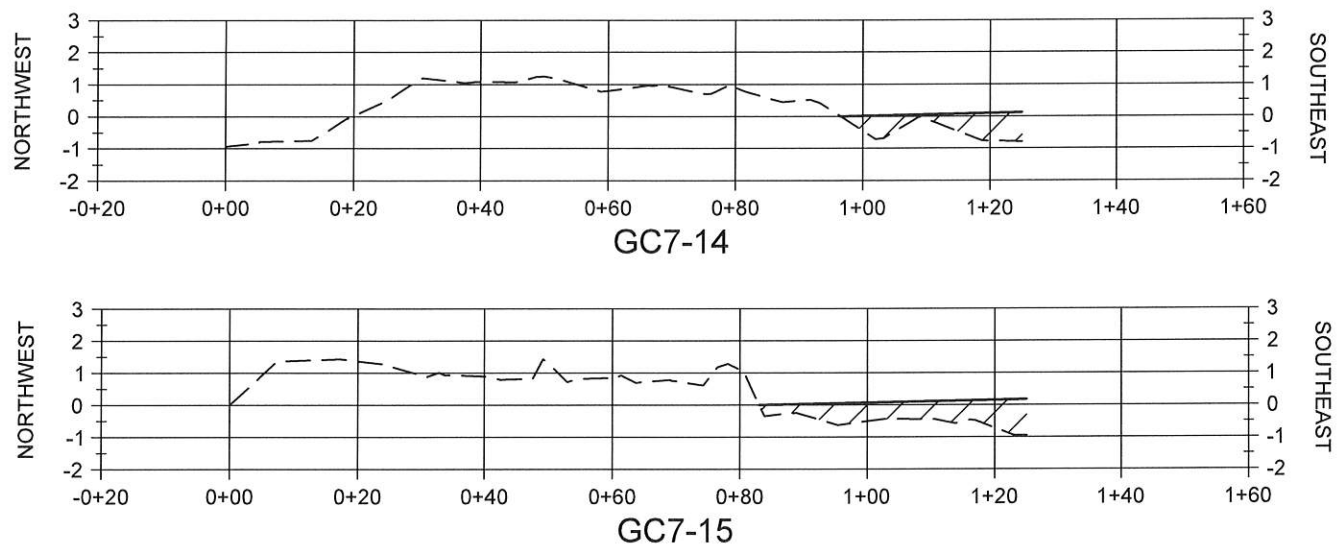
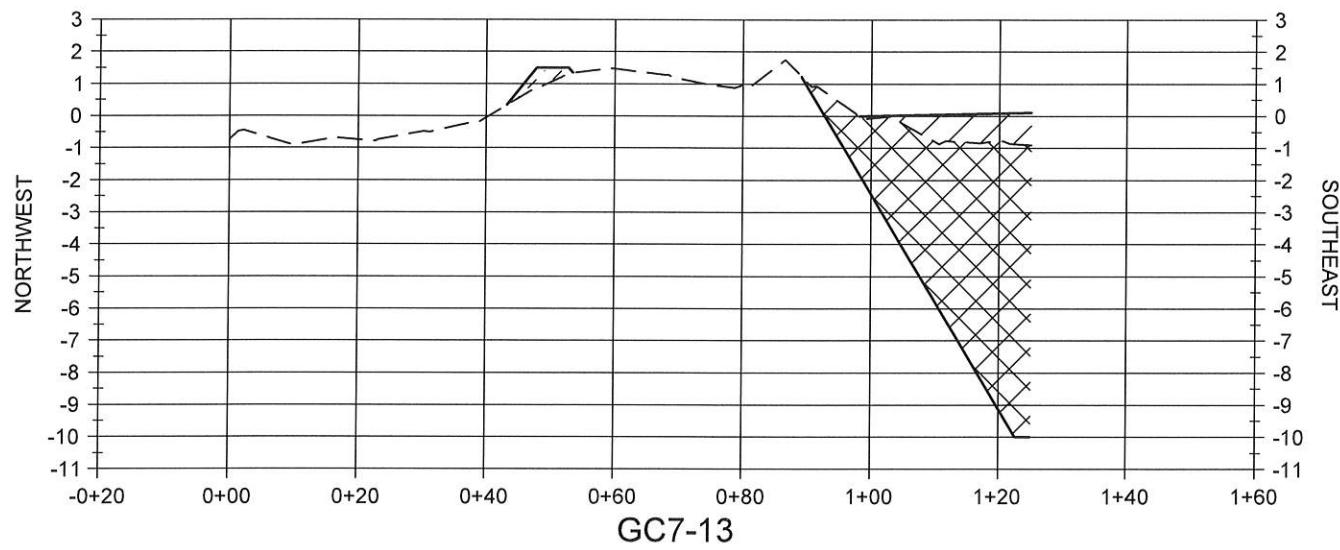

NOTE:
ALL ELEVATIONS ARE GIVEN IN THE NORTH AMERICAN
VERTICAL DATUM OF 1988 (NAVD88) GEOID 12A.



LEGEND	
	EARTHEN GAP CLOSURE
	EARTHEN GAP CLOSURE BORROW AREA
	MARSH CREATION FILL
	EXISTING GRADE

REV.	DATE	DESCRIPTION	BY

COASTAL PROTECTION AND RESTORATION AUTHORITY
150 TERRACE AVENUE
BATON ROUGE, LOUISIANA 70802

WEST MARSH CREATION AREA SECTIONS
DESIGNED BY: T. MCLAIN, E.I.
APPROVED BY: T. FITZGERALD, P.E. P.E. NO. 38153

NORTHWEST TURTLE BAY MARSH CREATION PROJECT
STATE PROJECT NUMBER: BA-0125
DRAWN BY: K. CANTU

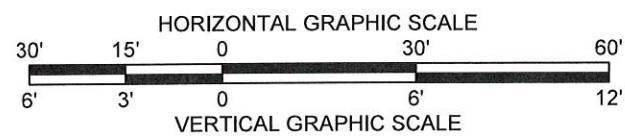
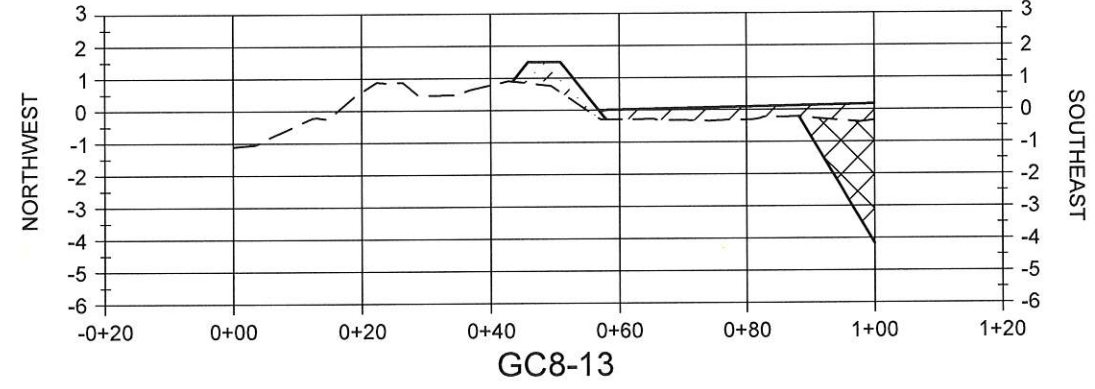
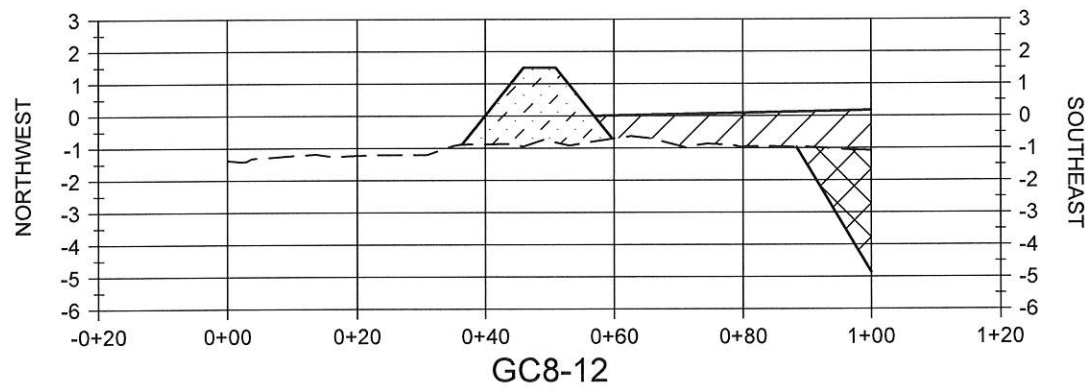
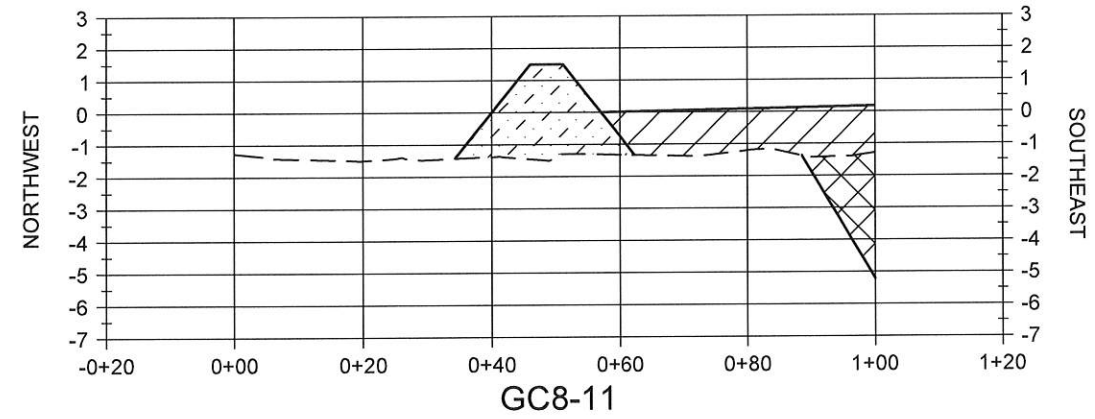
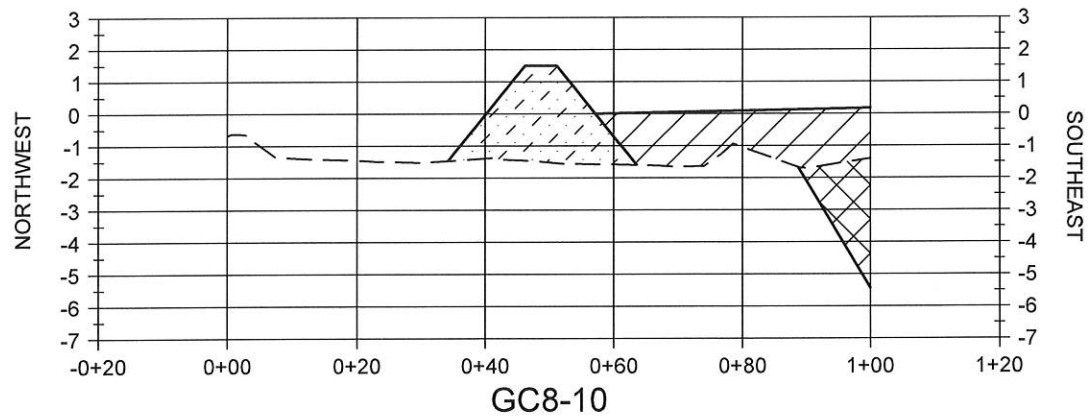
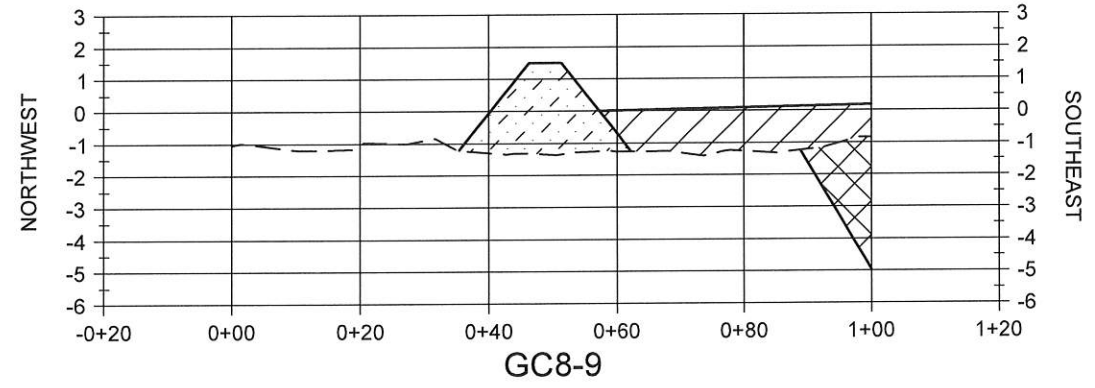
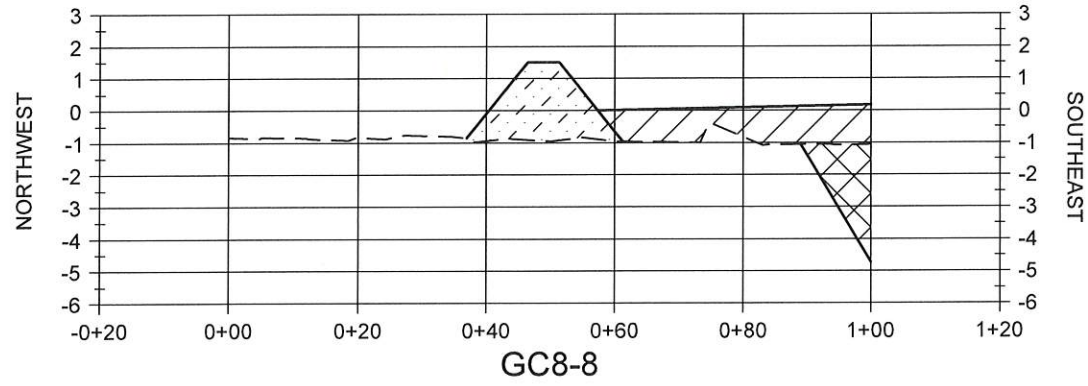
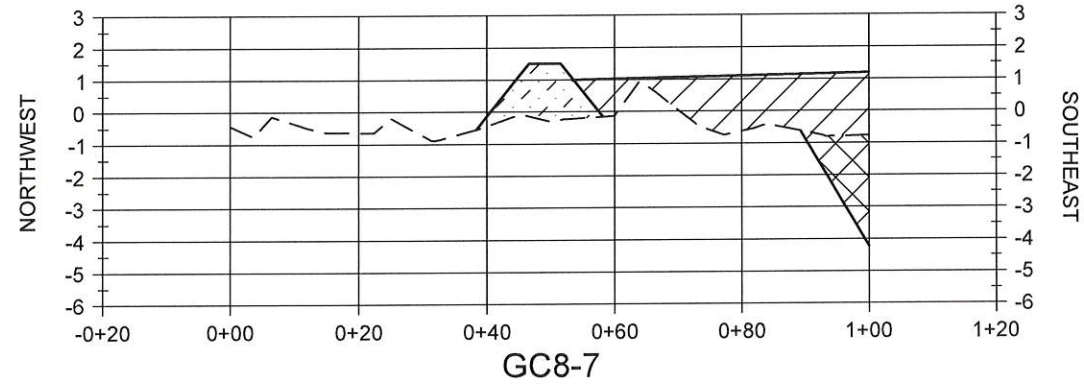
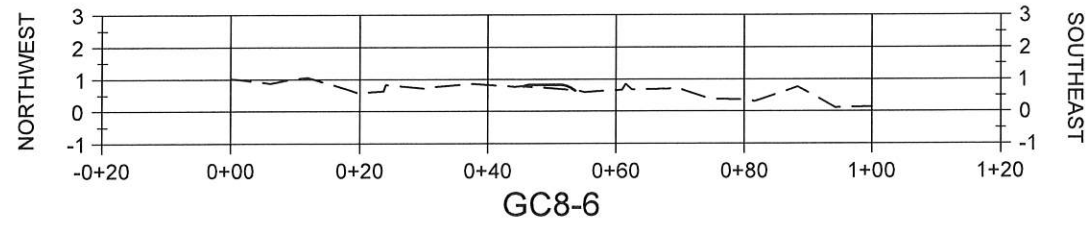

NOTE:
ALL ELEVATIONS ARE GIVEN IN THE NORTH AMERICAN
VERTICAL DATUM OF 1988 (NAVD88) GEOID 12A.



LEGEND	
	EARTHEN GAP CLOSURE
	EARTHEN GAP CLOSURE BORROW AREA
	MARSH CREATION FILL
	EXISTING GRADE

REV.	DATE	DESCRIPTION	BY

COASTAL PROTECTION AND
RESTORATION AUTHORITY
150 TERRACE AVENUE
BATON ROUGE, LOUISIANA 70802

WEST MARSH CREATION
AREA SECTIONS

DESIGNED BY: T. MCLAIN, E.I.
APPROVED BY: T. FITZGERALD, P.E. P.E. NO. 38153

NORTHWEST TURTLE BAY
MARSH CREATION PROJECT

STATE PROJECT NUMBER: BA-0125
DRAWN BY: K. CANTU

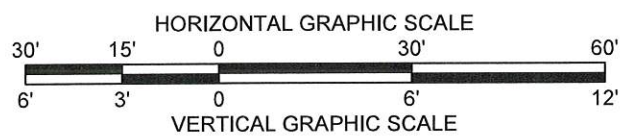
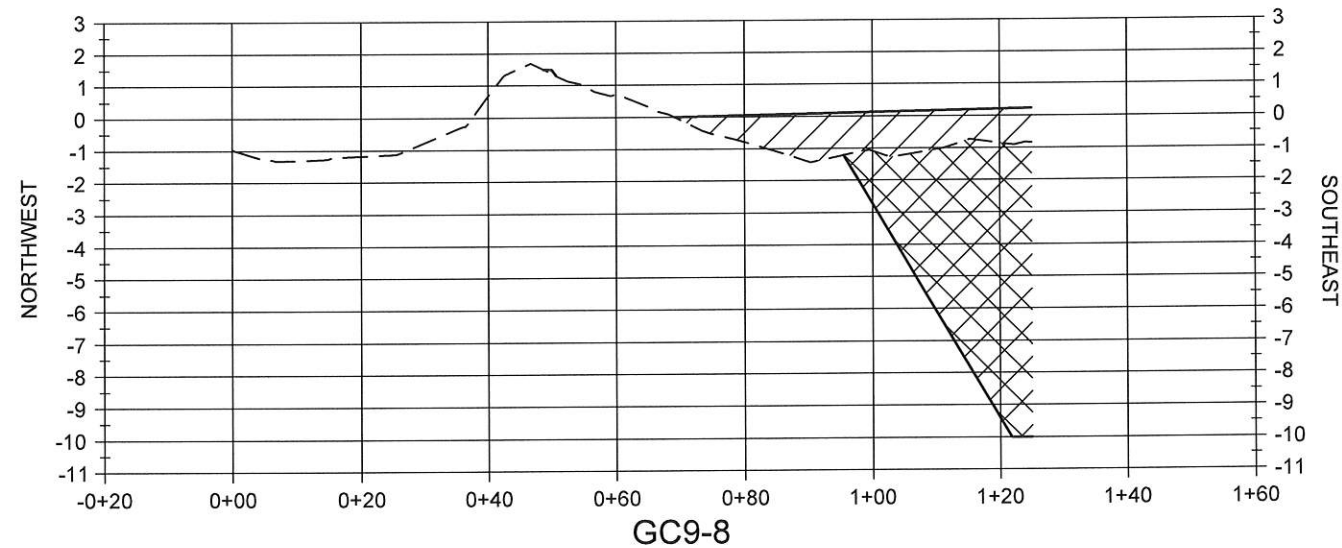
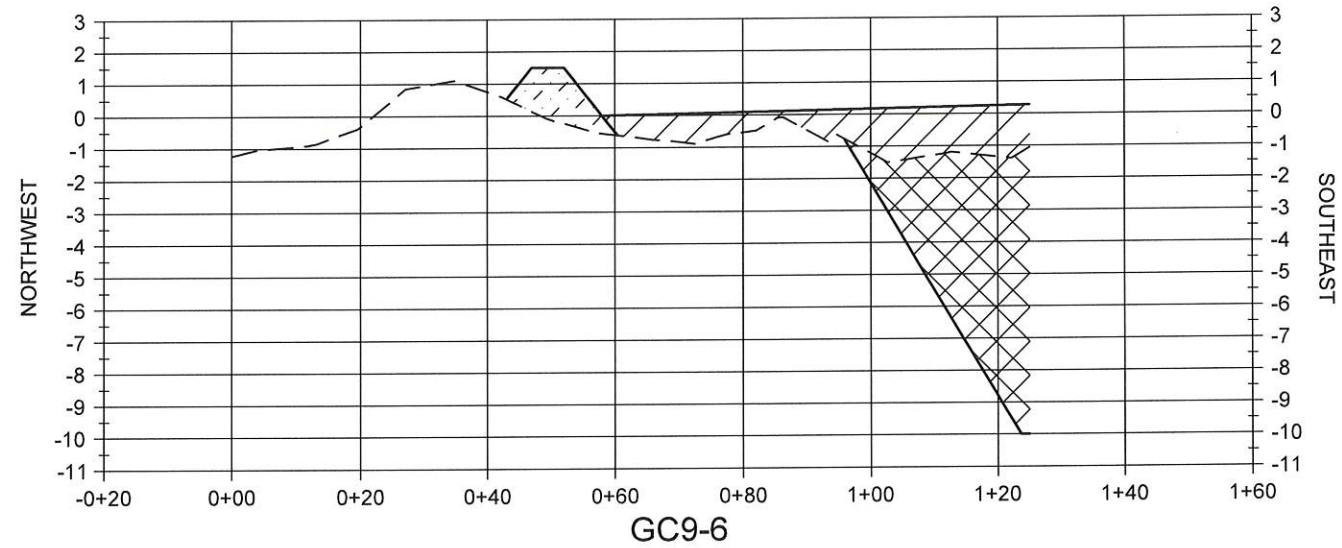
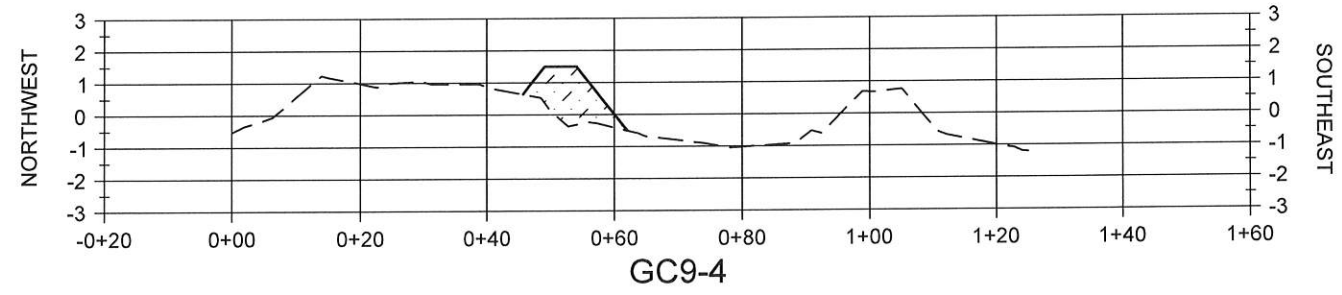
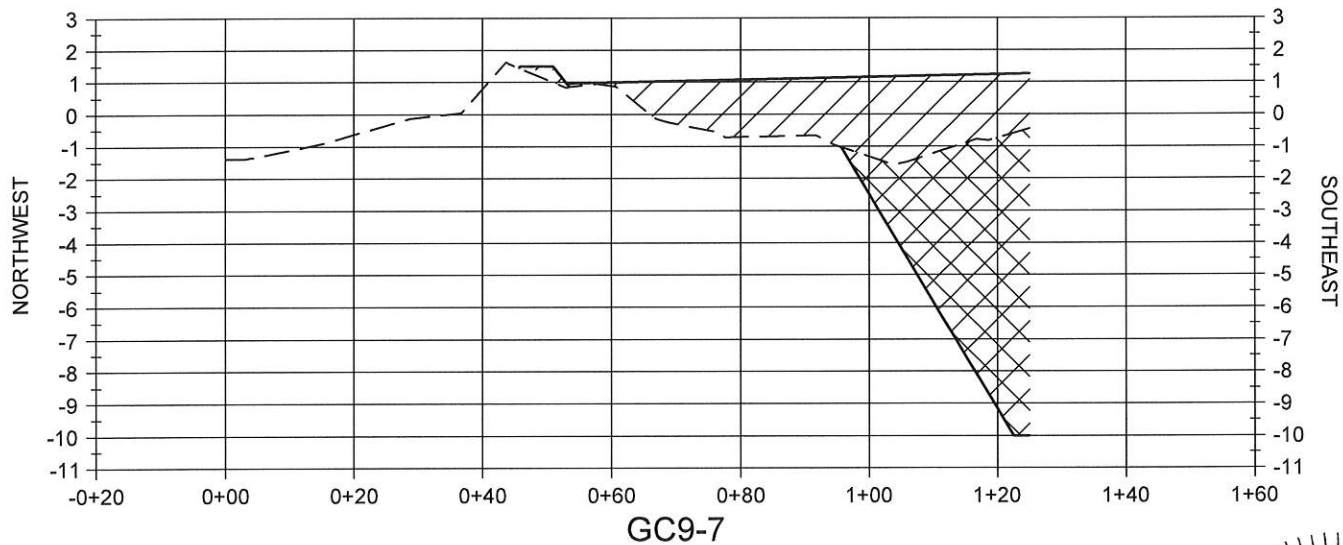
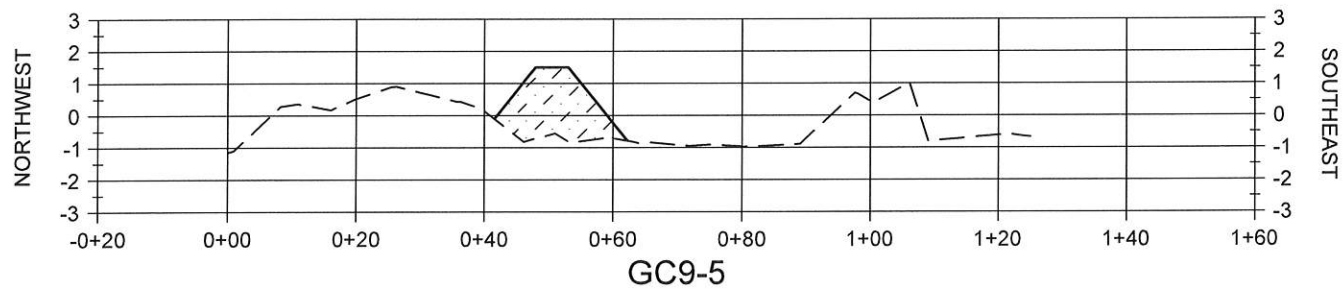
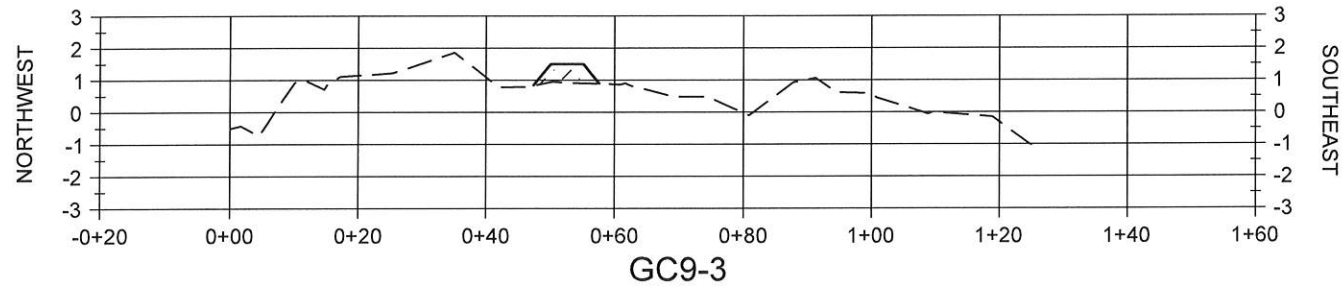

STATE OF LOUISIANA
 TYE E. FITZGERALD
 License No. 38153
 PROFESSIONAL ENGINEER
 CIVIL ENGINEERING
 12/12/2010

NOTE:
 ALL ELEVATIONS ARE GIVEN IN THE NORTH AMERICAN
 VERTICAL DATUM OF 1988 (NAVD88) GEOID 12A.

LEGEND	
	EARTHEN GAP CLOSURE
	EARTHEN GAP CLOSURE BORROW AREA
	MARSH CREATION FILL
	EXISTING GRADE

COASTAL PROTECTION AND RESTORATION AUTHORITY 150 TERRACE AVENUE BATON ROUGE, LOUISIANA 70802		DATE	BY
WEST MARSH CREATION AREA SECTIONS		REV.	DESCRIPTION
NORTHWEST TURTLE BAY MARSH CREATION PROJECT		STATE PROJECT NUMBER: BA-0125	
DESIGNED BY: T. MCLAIN, E.I.		APPROVED BY: T. FITZGERALD, P.E. P. E. NO. 38153	
DRAWN BY: K. CANTU		DATE: DEC. 2018	
SHEET 71 OF 79			

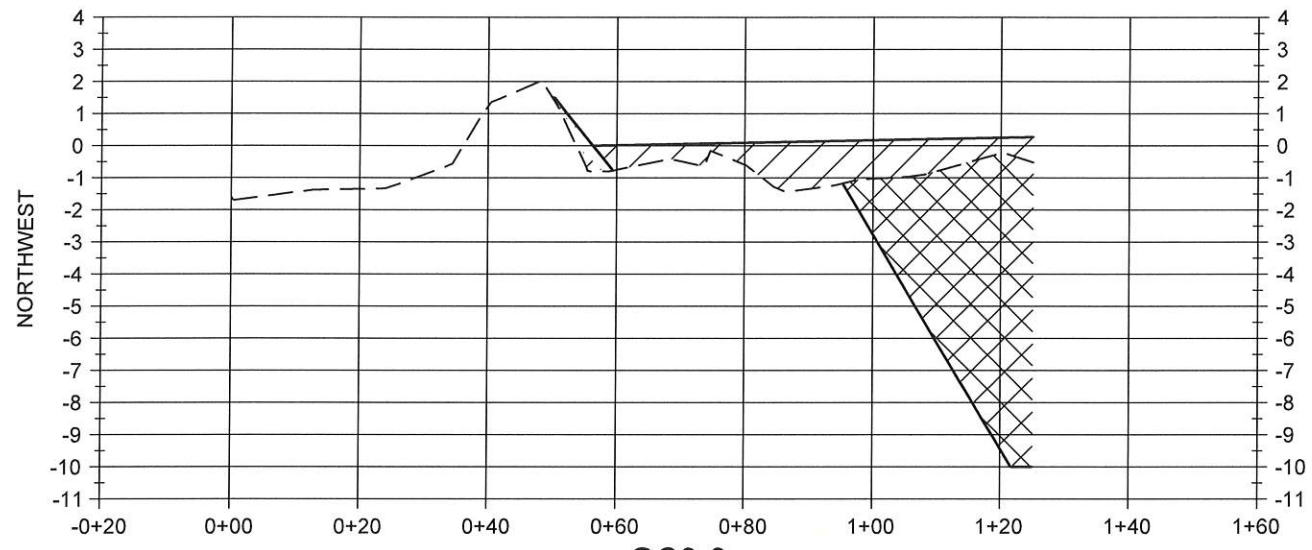

GC9-9

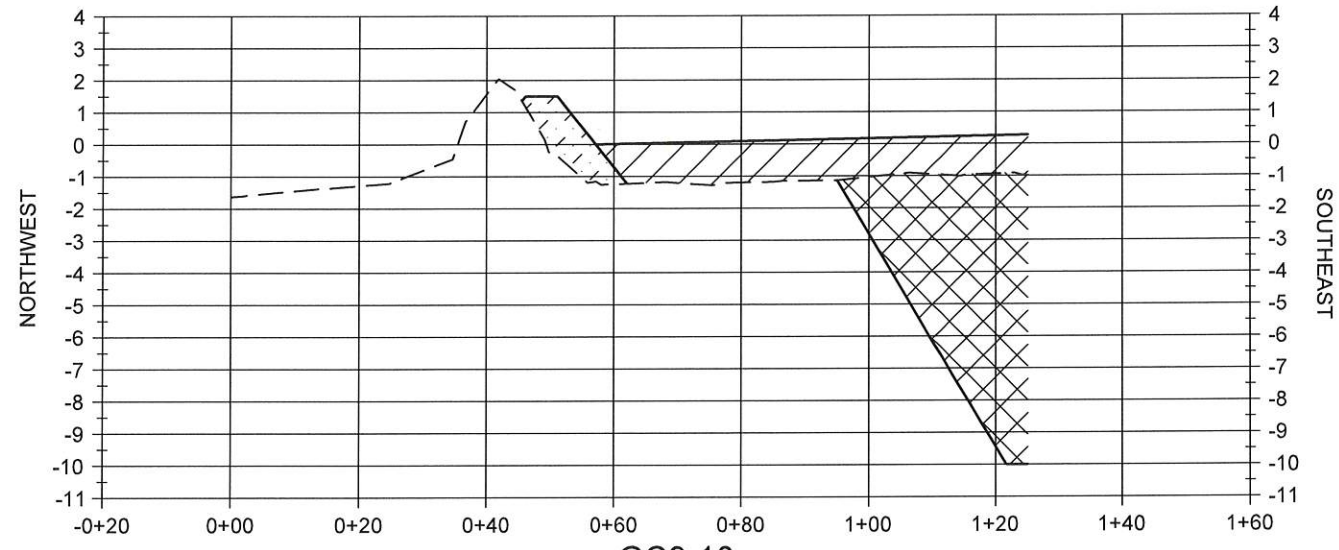

GC9-10

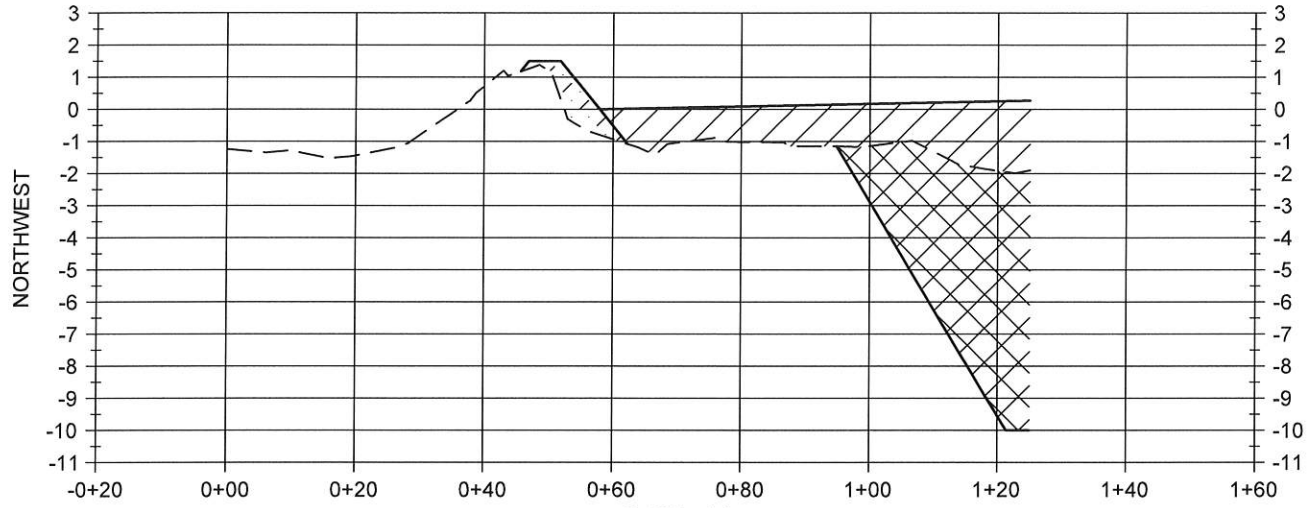

GC9-11

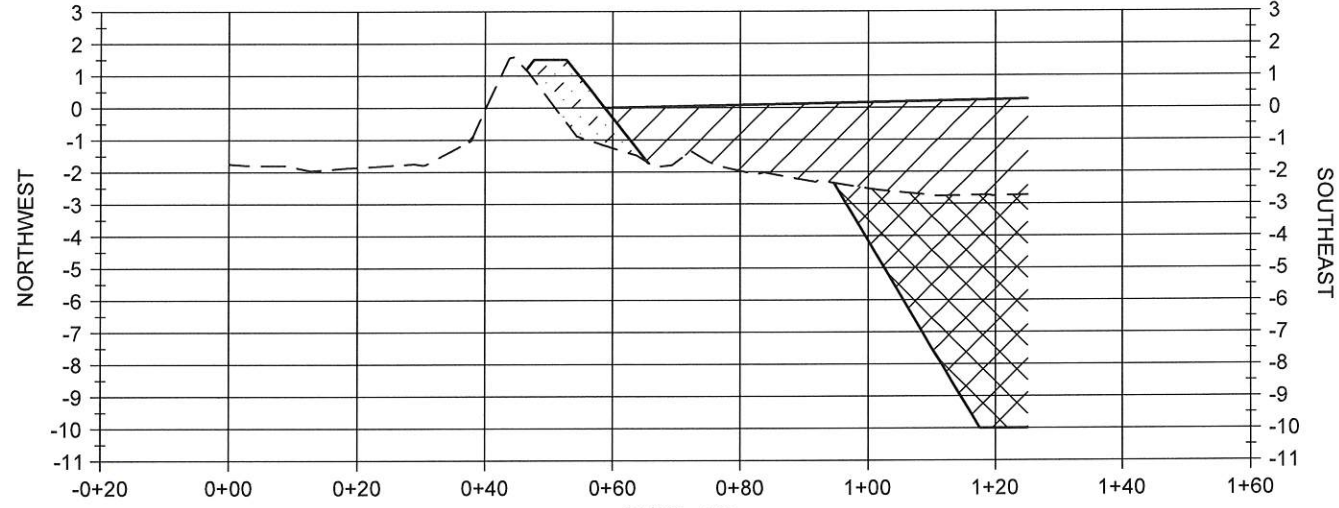

GC9-12

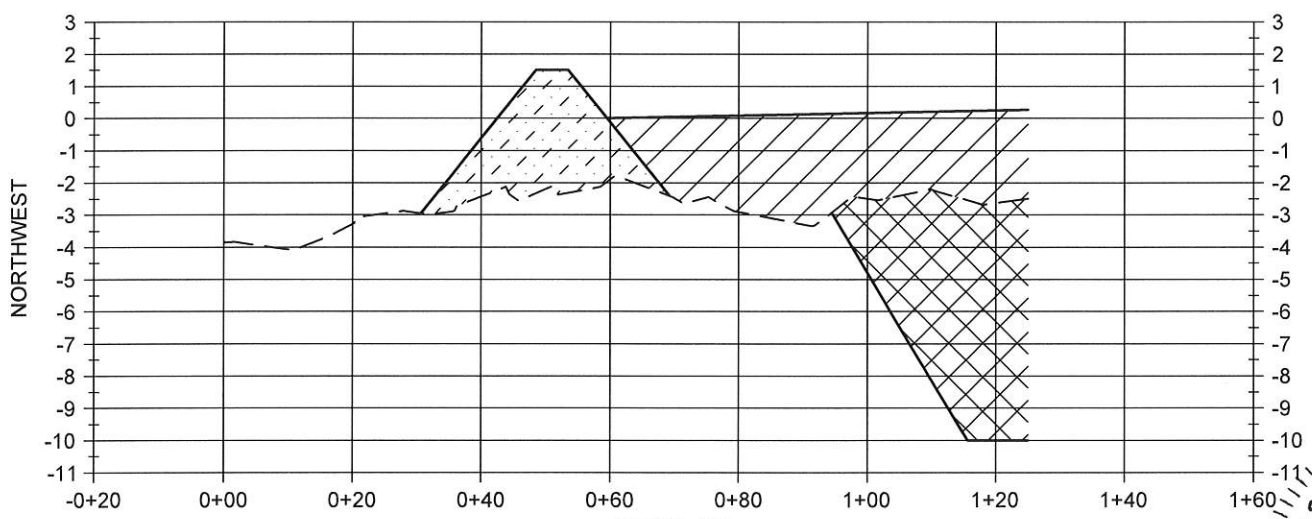

GC9-13

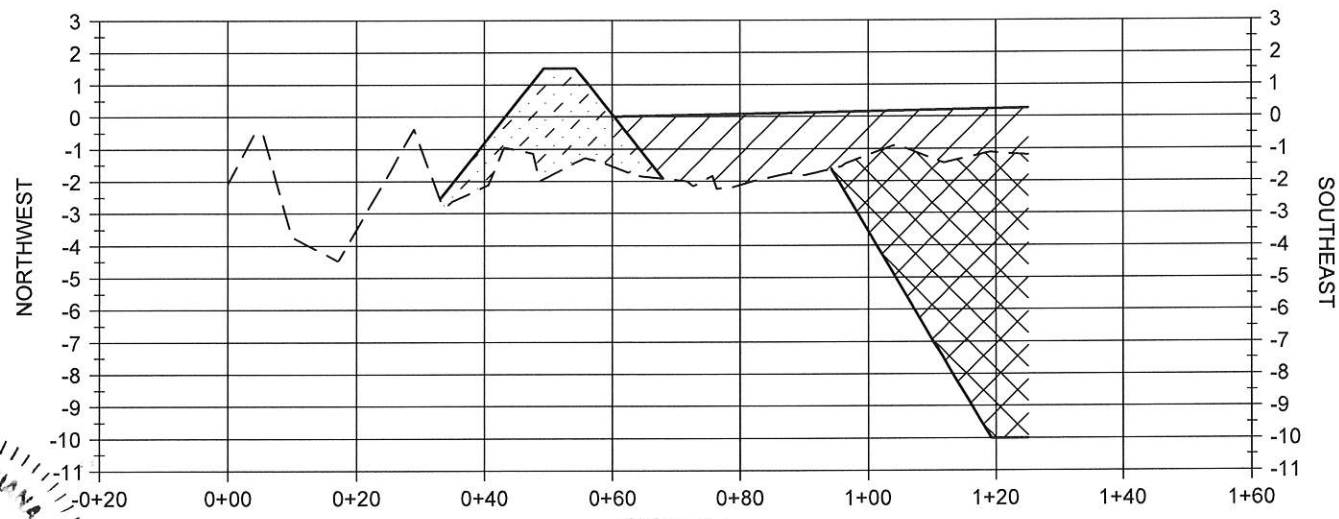

GC9-14

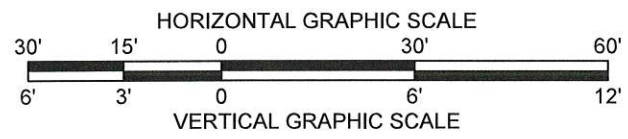

STATE OF LOUISIANA
 TYE E. FITZGERALD
 License No. 38153
 PROFESSIONAL ENGINEER
 IN
 CIVIL ENGINEERING

T. Fitzgerald
 12/12/2018

NOTE:
 ALL ELEVATIONS ARE GIVEN IN THE NORTH AMERICAN
 VERTICAL DATUM OF 1988 (NAVD88) GEOID 12A.

LEGEND	
	EARTHEN GAP CLOSURE
	EARTHEN GAP CLOSURE BORROW AREA
	MARSH CREATION FILL
	EXISTING GRADE

COASTAL PROTECTION AND RESTORATION AUTHORITY 150 TERRACE AVENUE BATON ROUGE, LOUISIANA 70802		DATE	DESCRIPTION	BY
WEST MARSH CREATION AREA SECTIONS		REV.		
NORTHWEST TURTLE BAY MARSH CREATION PROJECT		DESIGNED BY: T. MCLAIN, E.I. APPROVED BY: T. FITZGERALD, P.E. P.E. NO. 38153		
STATE PROJECT NUMBER: BA-0125		DRAWN BY: K. CANTU		
DATE: DEC. 2018		SHEET 72 OF 79		

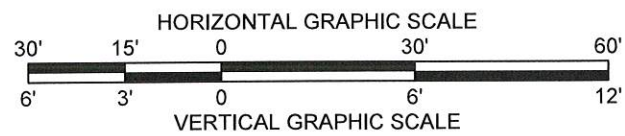
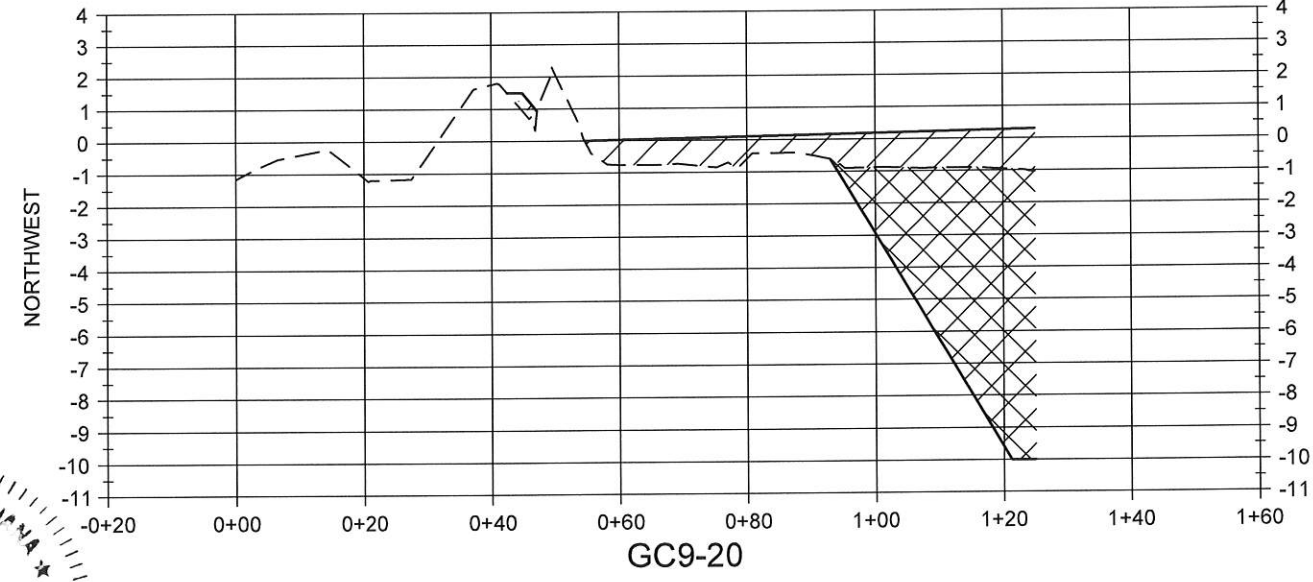
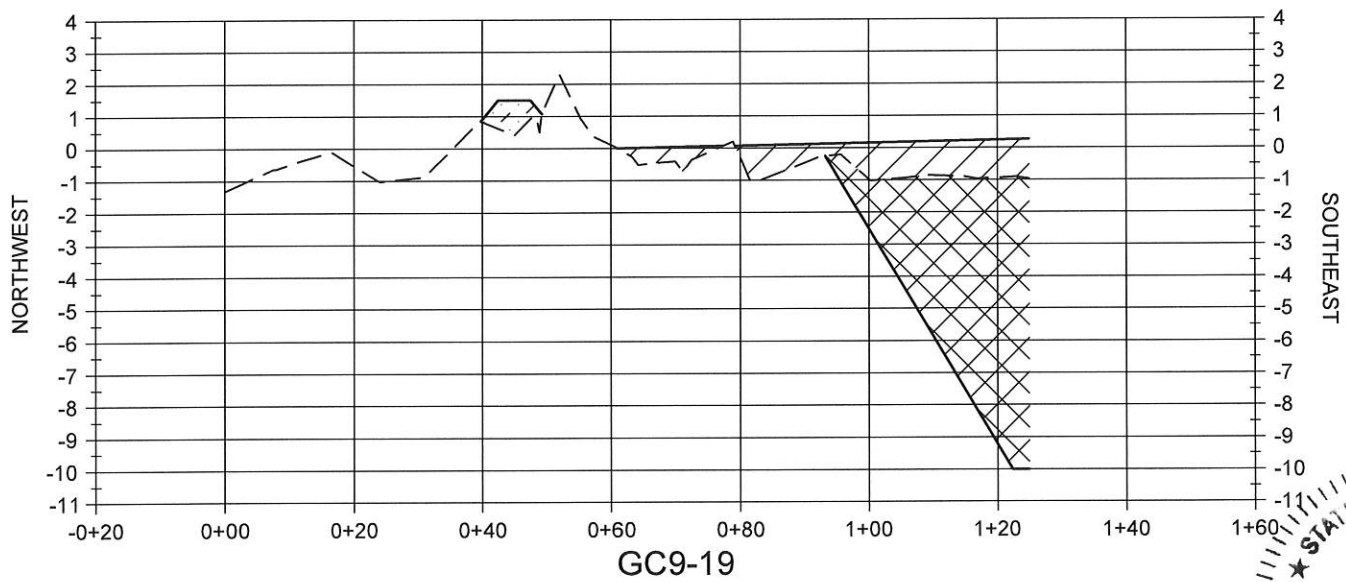
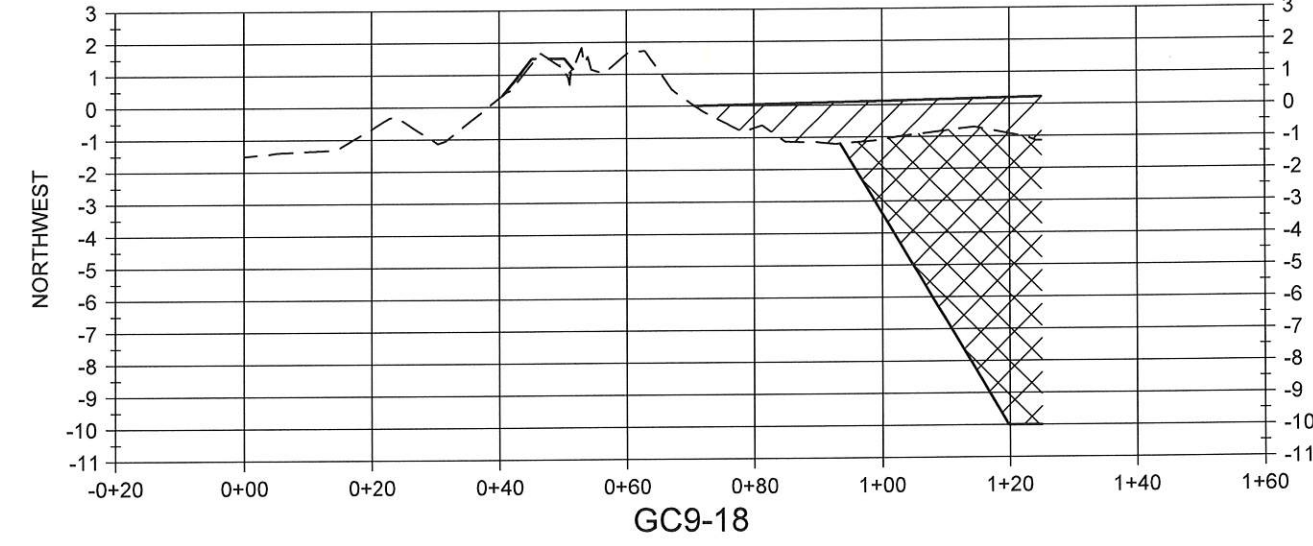
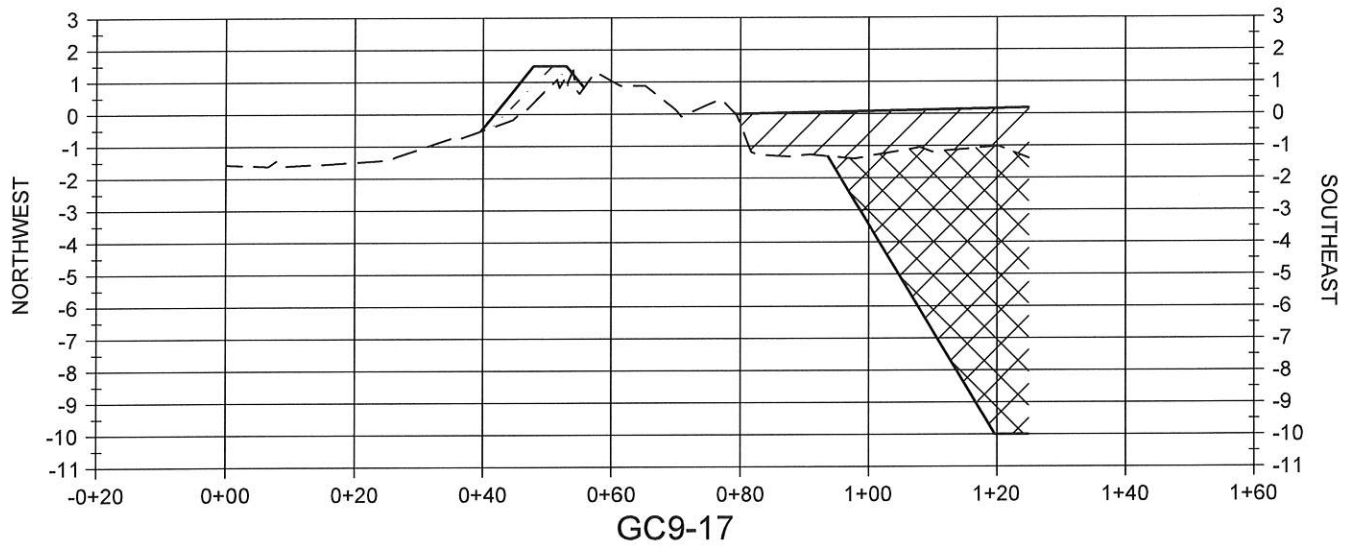
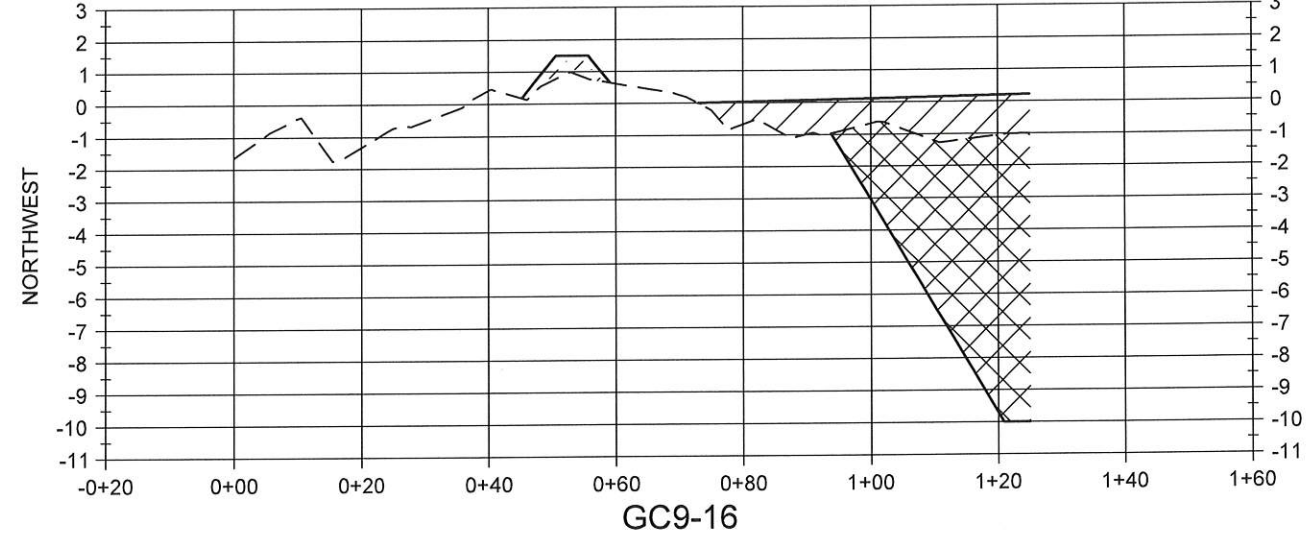
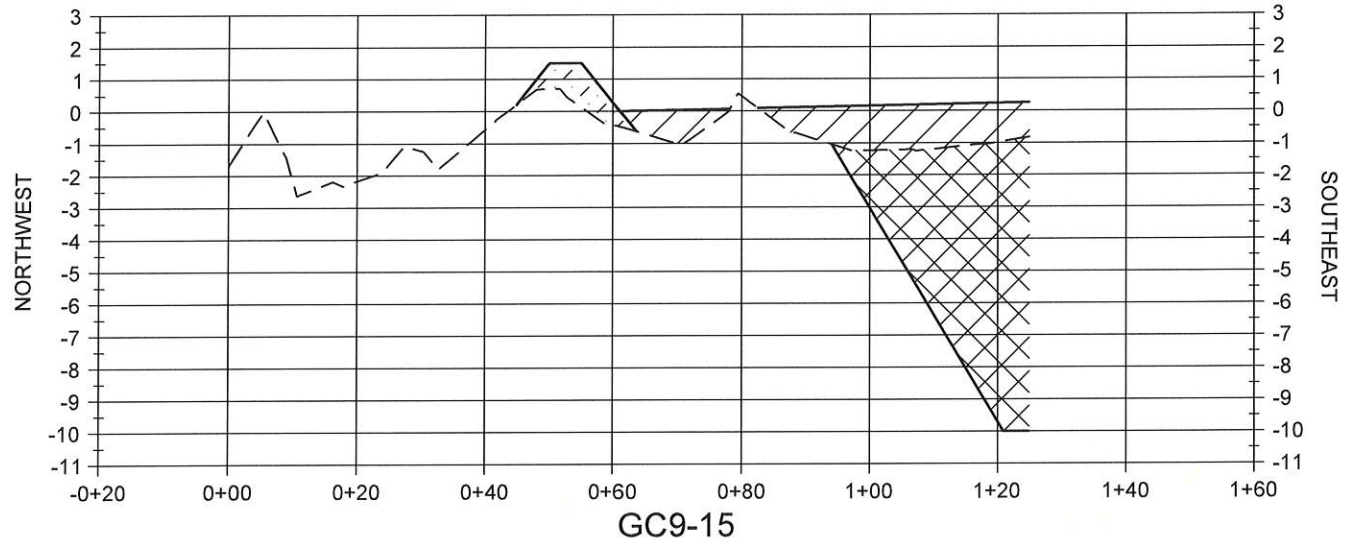

12/12/2018

NOTE:
ALL ELEVATIONS ARE GIVEN IN THE NORTH AMERICAN VERTICAL DATUM OF 1988 (NAVD88) GEOD 12A.

LEGEND	
	EARTHEN GAP CLOSURE
	EARTHEN GAP CLOSURE BORROW AREA
	MARSH CREATION FILL
	EXISTING GRADE

COASTAL PROTECTION AND RESTORATION AUTHORITY 150 TERRACE AVENUE BATON ROUGE, LOUISIANA 70802		REV.	DATE	DESCRIPTION	BY
WEST MARSH CREATION AREA SECTIONS		DESIGNED BY: T. MCLAIN, E.I. APPROVED BY: T. FITZGERALD, P.E. P.E. NO. 38153		DATE: DEC. 2018	
NORTHWEST TURTLE BAY MARSH CREATION PROJECT		STATE PROJECT NUMBER: BA-0125 DRAWN BY: K. CANTU		SHEET 73 OF 79	

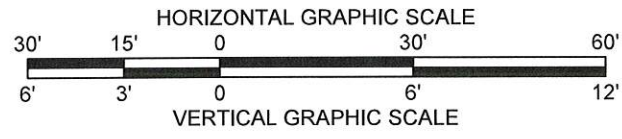
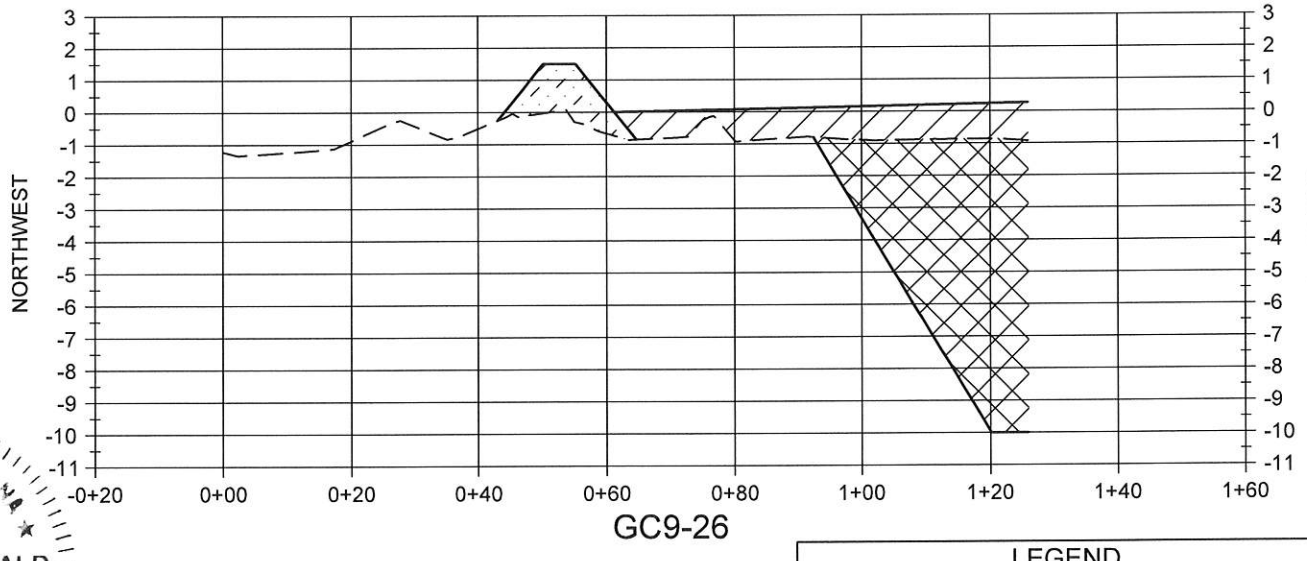
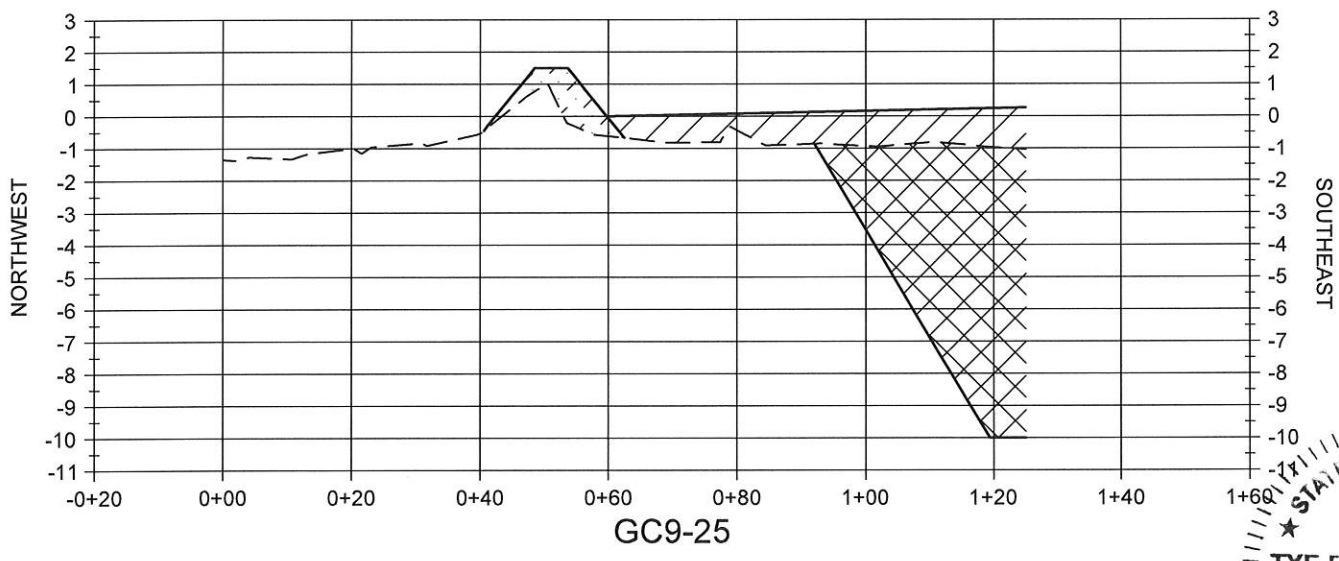
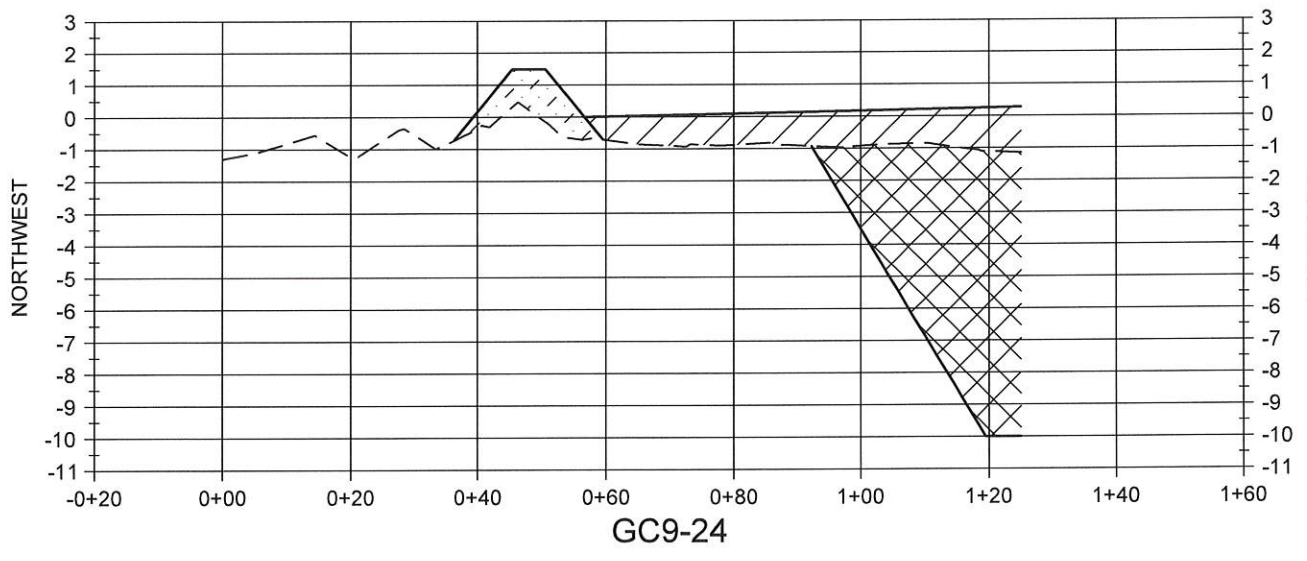
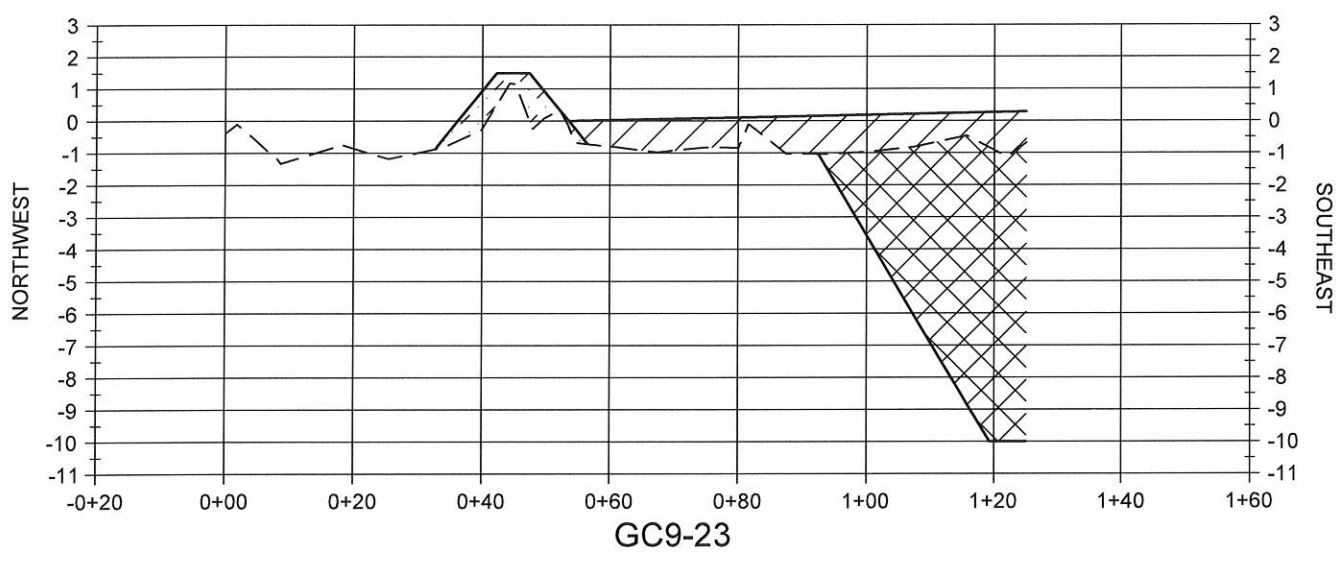
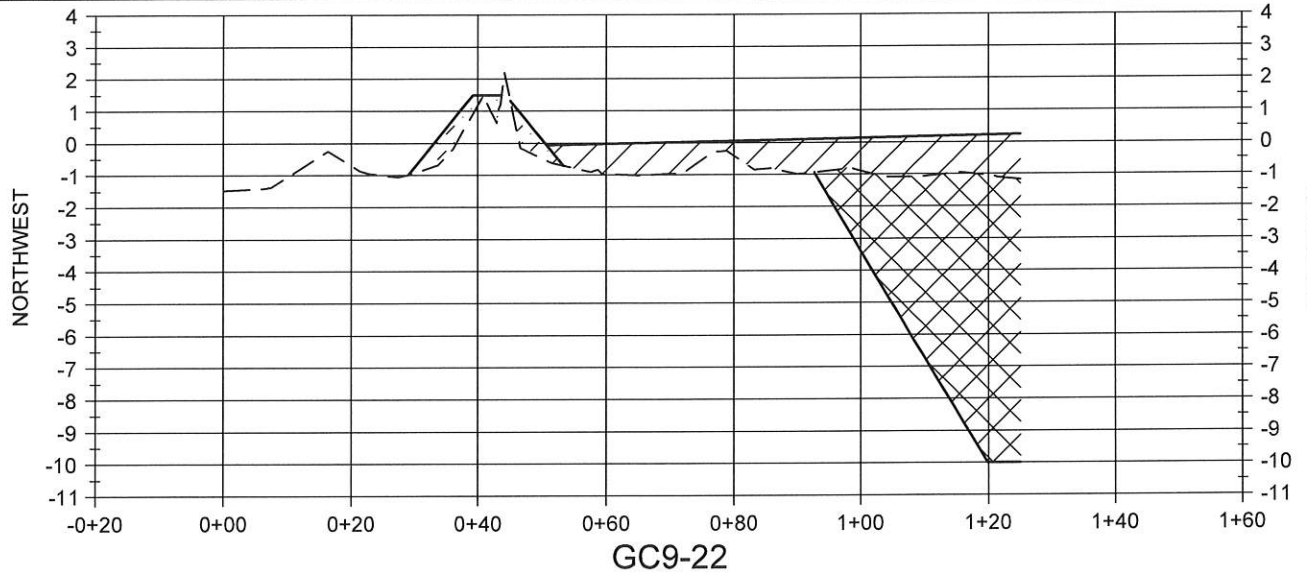
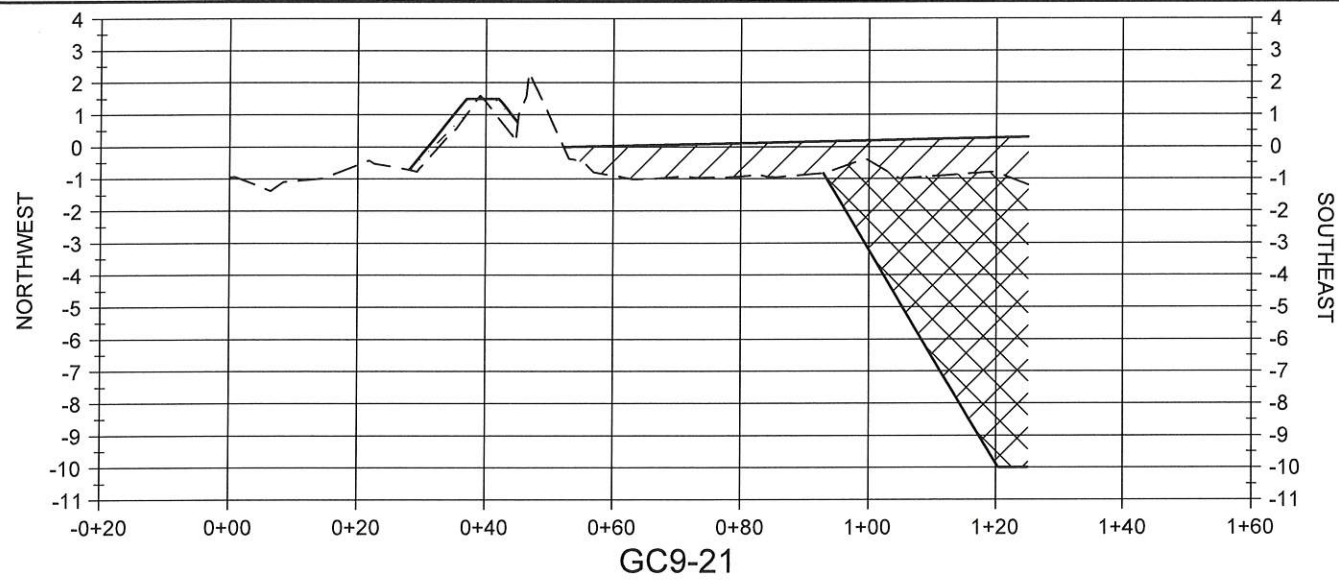

STATE OF LOUISIANA
TYE E. FITZGERALD
 License No. 38153
 PROFESSIONAL ENGINEER
 CIVIL ENGINEERING

12/12/2010

NOTE:
 ALL ELEVATIONS ARE GIVEN IN THE NORTH AMERICAN
 VERTICAL DATUM OF 1988 (NAVD88) GEOID 12A.

LEGEND	
	EARTHEN GAP CLOSURE
	EARTHEN GAP CLOSURE BORROW AREA
	MARSH CREATION FILL
	EXISTING GRADE

COASTAL PROTECTION AND RESTORATION AUTHORITY 150 TERRACE AVENUE BATON ROUGE, LOUISIANA 70802		DATE	DESCRIPTION	BY
WEST MARSH CREATION AREA SECTIONS				
NORTHWEST TURKLE BAY MARSH CREATION PROJECT				
STATE PROJECT NUMBER: BA-0125		DESIGNED BY: T. MCCLAIN, E.I.		
DRAWN BY: K. CANTU		APPROVED BY: T. FITZGERALD, P.E. P.E. NO. 38153		
DATE: DEC. 2018		SHEET 74 OF 79		

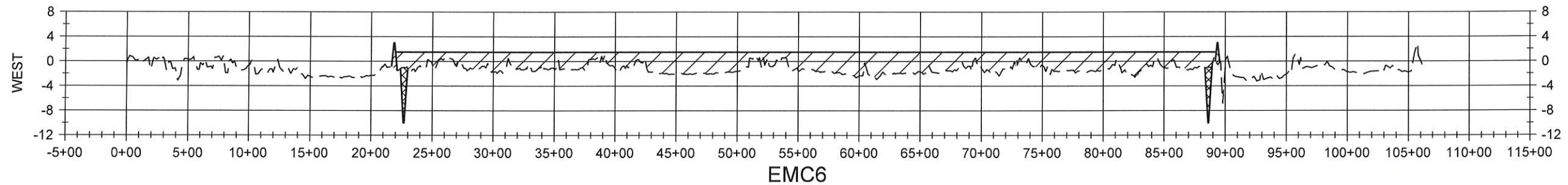

EMC6

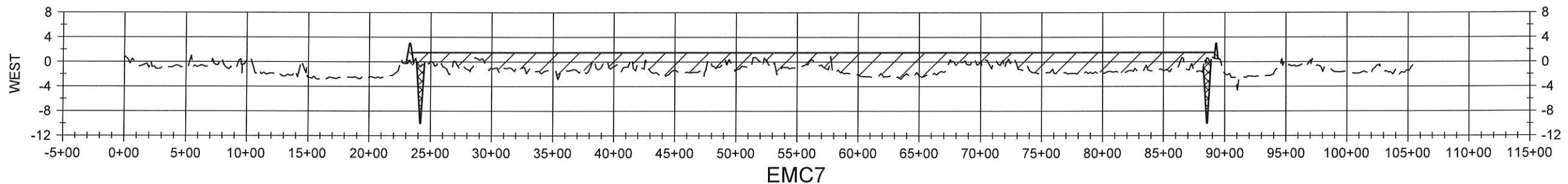

EMC7

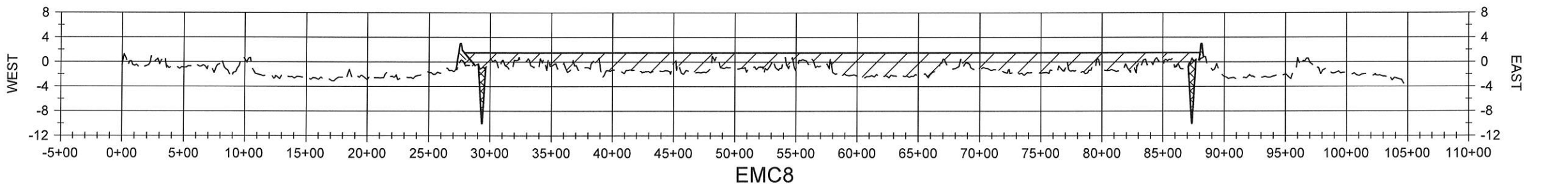

EMC8

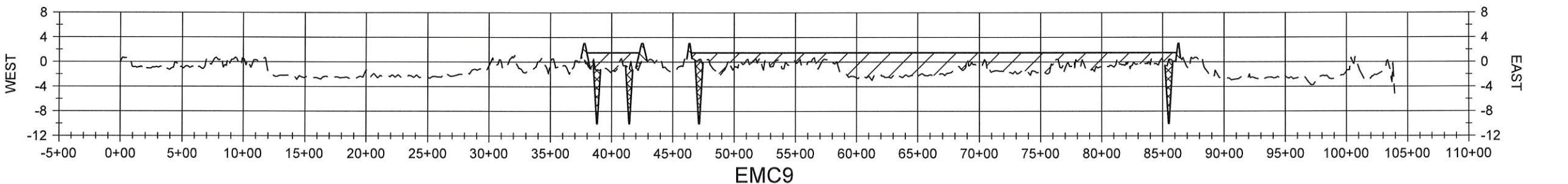

EMC9

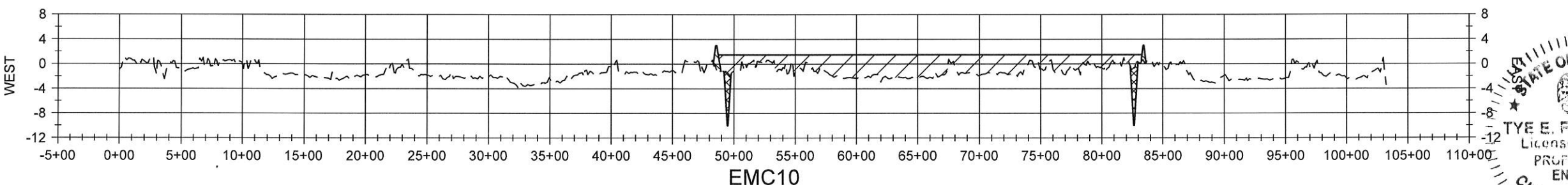

EMC10

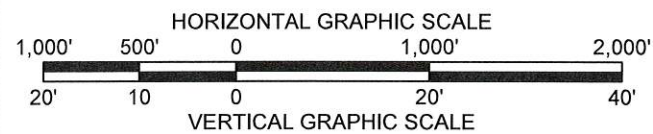

LEGEND	
	EARTHEN CONTAINMENT DIKE
	MARSH CREATION FILL
	EARTHEN CONTAINMENT DIKE BORROW AREA
	EXISTING GROUND/WATER BOTTOM

NOTE:
ALL ELEVATIONS ARE GIVEN IN THE NORTH AMERICAN
VERTICAL DATUM OF 1988 (NAVD88) GEOID 12A.



COASTAL PROTECTION AND RESTORATION AUTHORITY 150 TERRACE AVENUE BATON ROUGE, LOUISIANA 70802		DESIGNED BY: T. MCCLAIN, E.I.	APPROVED BY: T. FITZGERALD, P.E. P.E. NO. 38153
		STATE PROJECT NUMBER: BA-0125	DRAWN BY: K. CANTU
EAST MARSH CREATION AREA SECTIONS		NORTHWEST TURTLE BAY MARSH CREATION PROJECT	
DATE: DEC. 2018	SHEET 77 OF 79		

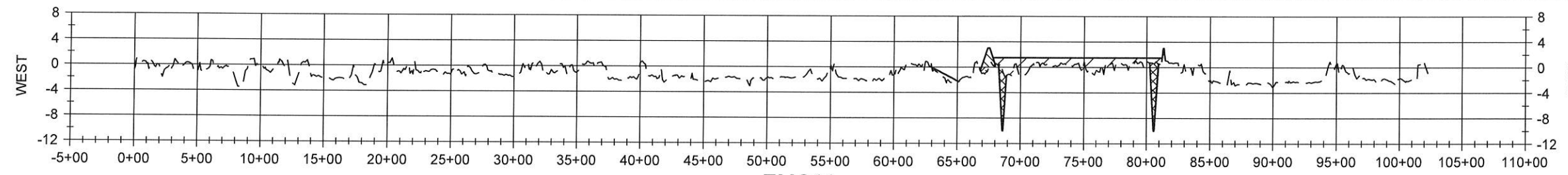

EMC11

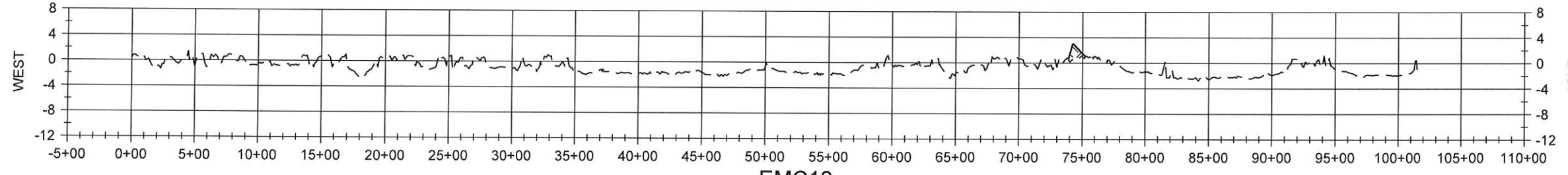

EMC12

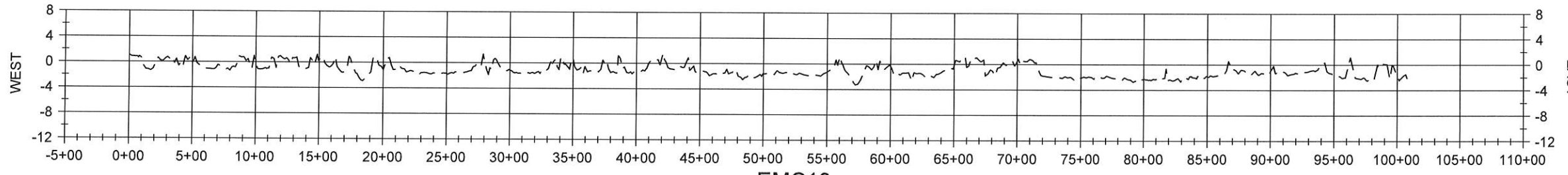

EMC13

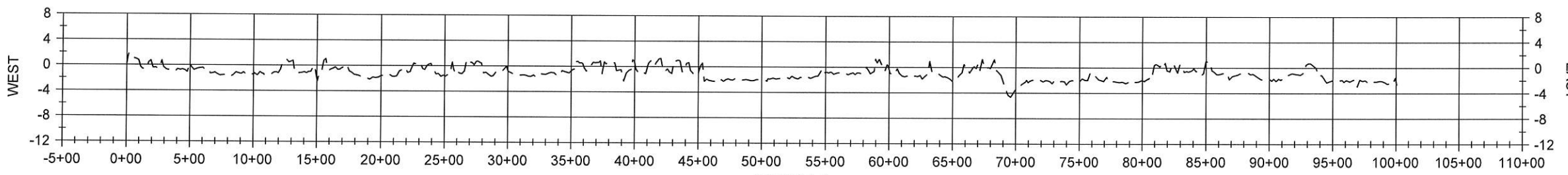

EMC14

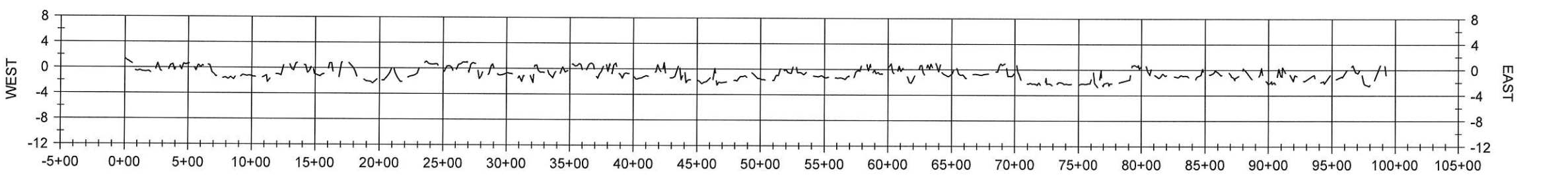

EMC15

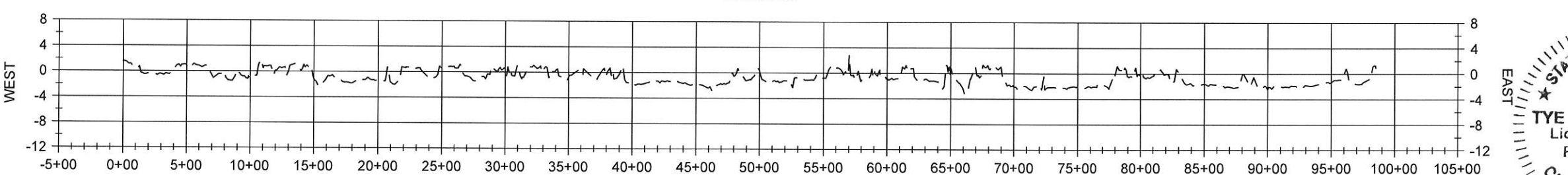

EMC16

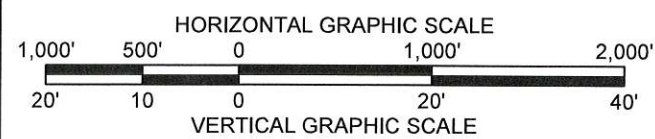

LEGEND	
	EARTHEN CONTAINMENT DIKE
	MARSH CREATION FILL
	EARTHEN CONTAINMENT DIKE BORROW AREA
	EXISTING GROUND/WATER BOTTOM

NOTE:
ALL ELEVATIONS ARE GIVEN IN THE NORTH AMERICAN
VERTICAL DATUM OF 1988 (NAVD88) GEOID 12A.



COASTAL PROTECTION AND RESTORATION AUTHORITY 150 TERRACE AVENUE BATON ROUGE, LOUISIANA 70802		REV.	DATE	BY
EAST MARSH CREATION AREA SECTIONS		DESIGNED BY: T. MCLAIN, E.I.	APPROVED BY: T. FITZGERALD, P.E. P.E. NO. 38153	
		STATE PROJECT NUMBER: BA-0125	DRAWN BY: K. CANTU	
NORTHWEST TURTLE BAY MARSH CREATION PROJECT		DATE: DEC. 2018		
		SHEET 78 OF 79		

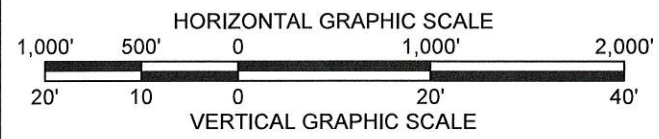
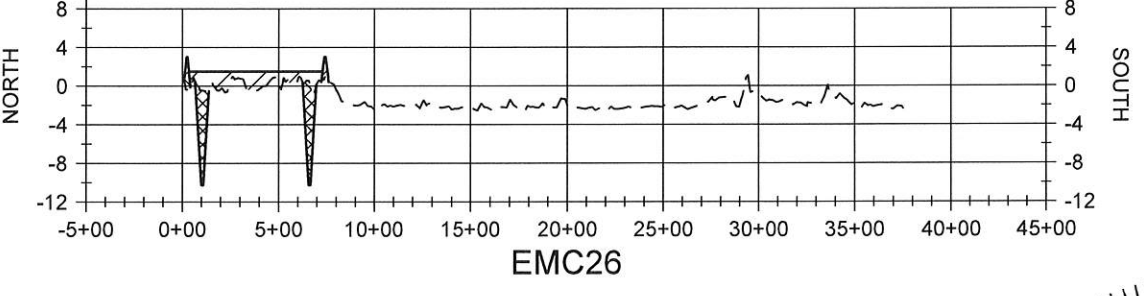
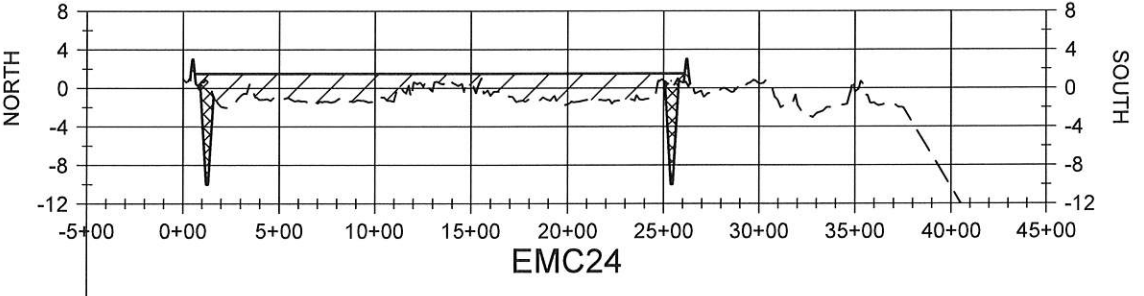
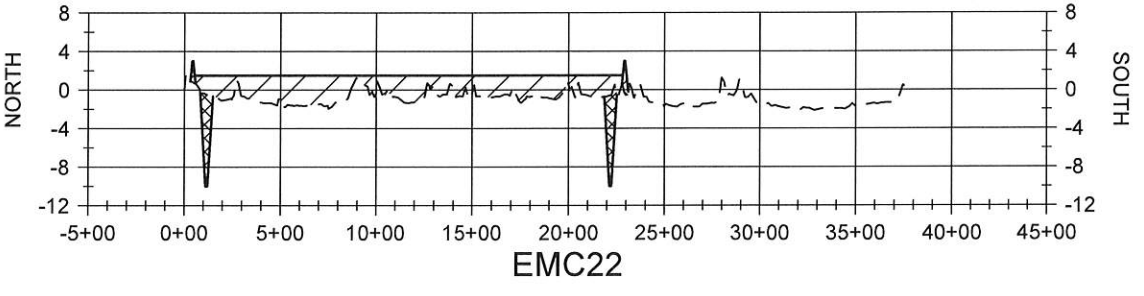
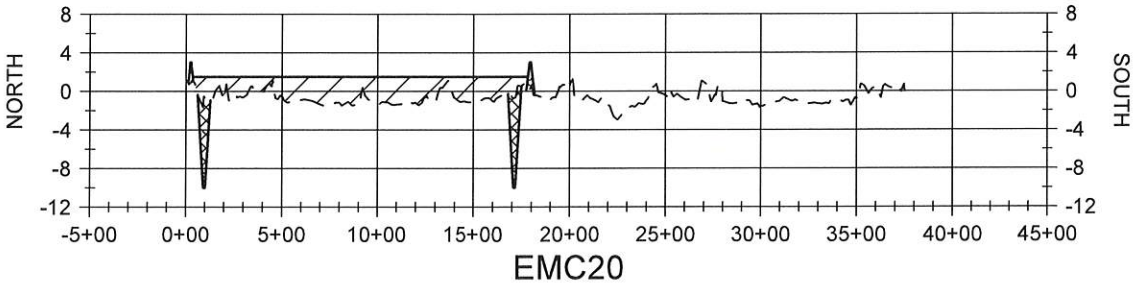
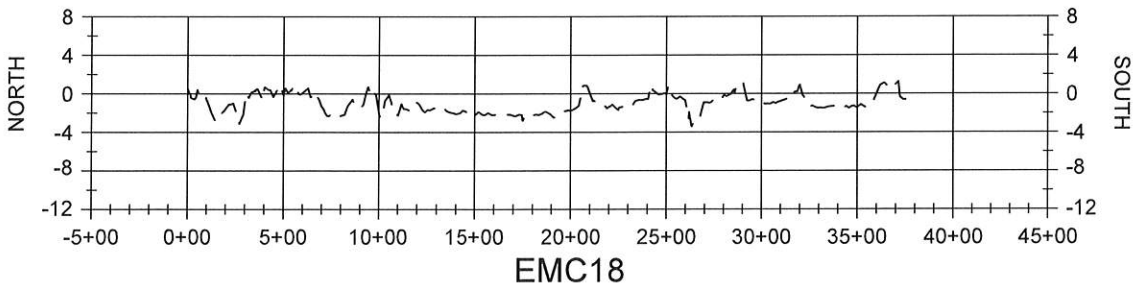
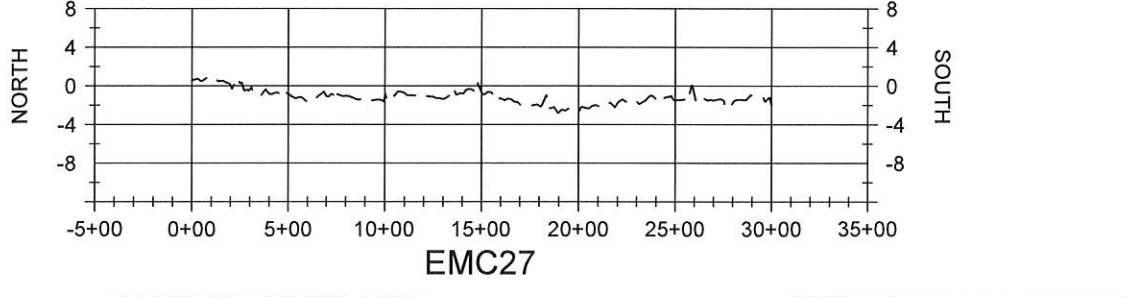
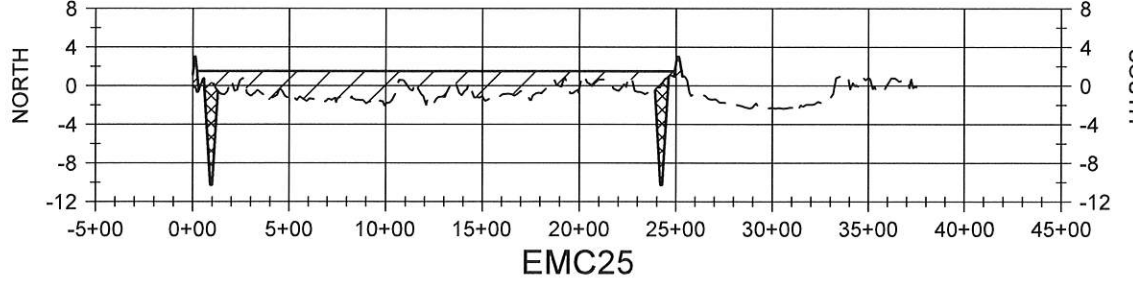
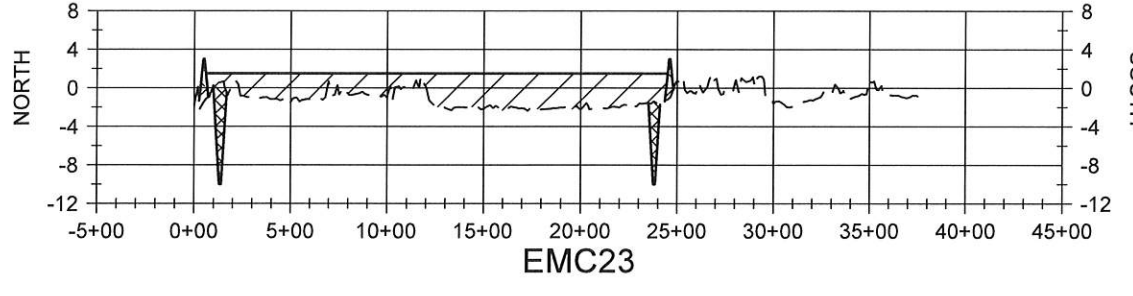
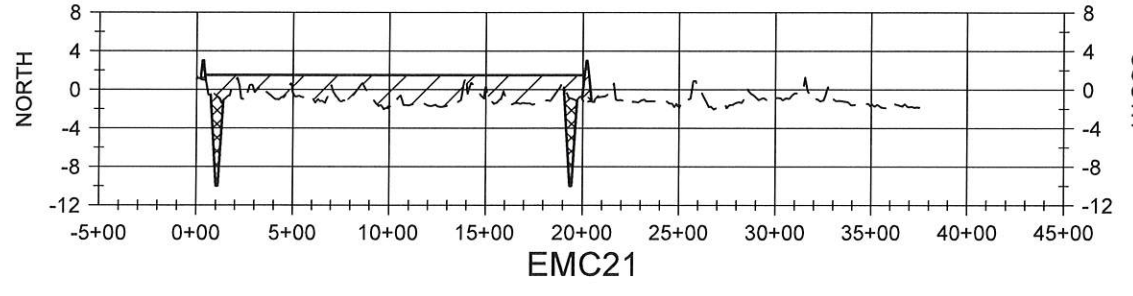
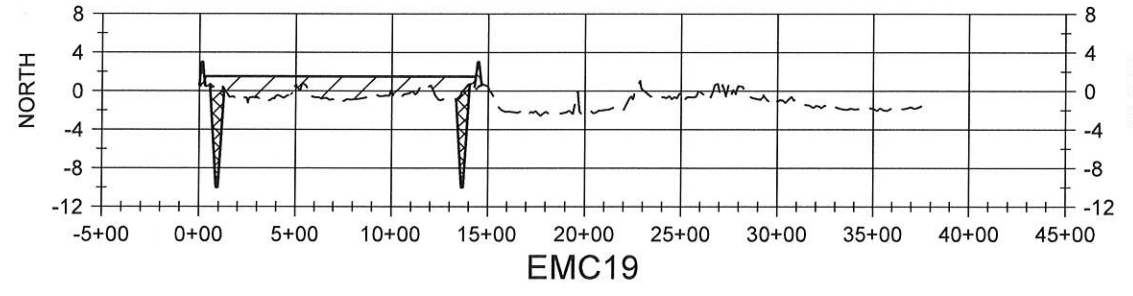
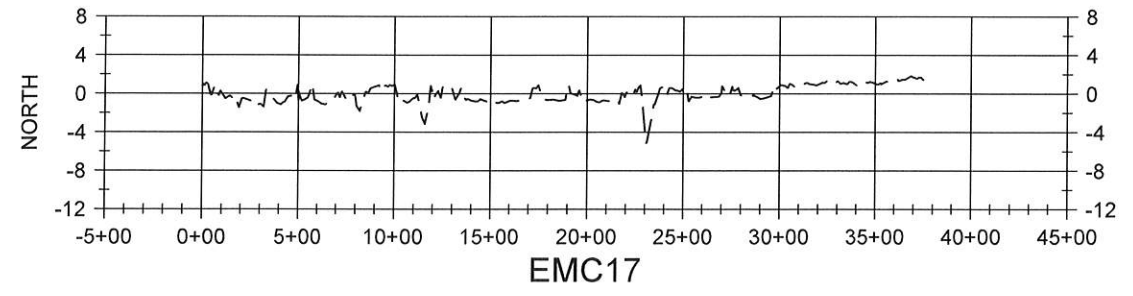

LEGEND	
	EARTHEN CONTAINMENT DIKE
	MARSH CREATION FILL
	EARTHEN CONTAINMENT DIKE BORROW AREA
	EXISTING GROUND/WATER BOTTOM



NOTE:
ALL ELEVATIONS ARE GIVEN IN THE NORTH AMERICAN
VERTICAL DATUM OF 1988 (NAVD88) GEOID 12A.

COASTAL PROTECTION AND RESTORATION AUTHORITY 150 TERRACE AVENUE BATON ROUGE, LOUISIANA 70802	
EAST MARSH CREATION AREA SECTIONS	DESIGNED BY: T. MCLAIN, E.I. APPROVED BY: T. FITZGERALD, P.E. P.E. NO. 38153
NORTHWEST TURTLE BAY MARSH CREATION PROJECT	STATE PROJECT NUMBER: BA-0125 DRAWN BY: K. CANTU
DATE: DEC. 2018	
SHEET 79 OF 79	